



TECHNICAL GUIDE

DRYWALL
Grid Systems

Hanging and Framing
Flat Ceilings



Work Smarter

Eliminate the labor-intensive cutting, tying, and spacing of track and channel framing. Our systems are engineered with route locations and cross tees to maintain precise module spacing. Main beams have 51 route locations and cross tee lengths of 50", 26", and 14" to accommodate type "F" fixtures without field modifications or accessories. Pre-notched main beams simplify curved drywall installations.

Our Drywall Systems are manufactured to meet or exceed ASTM standards and code requirements, and are engineered to provide economical alternatives to stud and track construction.



DRYWALL Grid Systems

Code Compliance You Can Trust

Meets:

- ASTM C635
- ASTM C645
- ASTM C754
- ASTM C840
- ICC Evaluation Service Report ESR-1289
- City of LA – RR 25348
- IBC categories D, E, and F single layer drywall ceilings are exempt from lateral force bracing requirements, regardless of room size
- Miami-Dade County, Florida wind uplift – NOA No. 07-0119.02 – 03/17/2014
- Miami-Dade County, Florida impact testing – NOA No. 10-0126.04 – 03/17/2015
- Consult local codes for specific requirements

Performance

- **PeakForm®** patented profile increases strength and stability for improved performance during installation
- **SuperLock™2** main beam clip is engineered for a strong secure connection and fast accurate alignment confirmed with an audible click; easy to remove and relocate
- **ScrewStop™** reverse hem prevents screw spin off on 1-1/2" wide face
- **Rotary-stitched** – Greater torsional strength and stability
- **1-1/2" wide face** main beams and cross tees – Easy installation of screw-applied gypsum wallboard
- **G40, G90 hot dipped galvanized coating** – Corrosion resistance



Flat Drywall Grid Installation

Table of Contents

- **G90 hot dipped galvanized coating** – Superior corrosion resistance for exterior applications
- **Heavy-duty load rating** – Minimum 16 Lbs/LF on main beams
- **Fire rated** – Applicable to 25 UL Fire Resistant designs (D501, D502, G523, G524, G527, G528, G529, G553, J502, L502, L508, L513, L515, L525, L526, L529, L564, P501, P506, P507, P508, P509, P510, P513, P514, P516). Item XL7936G90 and XL8965 are not fire rated.
Wind uplift and impact testing construction available, including Miami Dade/Broward County, Florida
- **Cross tee spacing:**
24" O.C. for 5/8" drywall
16" O.C. for 1/2" drywall

2	Code Compliance	16-19	Suspended Drywall Grid System Details
2-3	Performance	20-30	Hanging and Framing
4	Components	20	Wire Loading
4	Main Beams	20	9 Gauge Wire Breaking Strength and Technical Data
4	Cross Tees	20	12 Gauge Wire Breaking Strength and Technical Data
5	Moldings	20	Counter Splayed Wires
5	Wall Molding	21	Yoke Wire Hung Ceilings
6	G40 and G90 Corrosion Prevention	21	Single Yoke
6	Transitions Wall Molding	21	Double Yoke
7-10	Axiom® Trim	22	Trapeze Supported Loads
7	Transitions Trim	23	Double Hung Ceilings
8	One-Piece Drywall Trim	23	Gusset Hung Ceilings
9-10	Building Perimeter System	24	Triple Hung Ceilings
11-12	Route Locations	25	Wind Load
12-13	Accessories	26-27	UL Fire Resistive Designs
14-15	Hanging and Framing	27	Fire Rated Expansion Joint
14	System Framing	28	Load Test Data
14	Squaring Up the System	28	Membrane Load Values
15	Type "F" Fixtures	29	Basic Products Used on Suspension Systems
		29	Control Joints & Expansion Joints
		30	Sound Isolation
		31	Estimating Materials

DRYWALL Grid Systems

Components

components

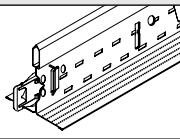
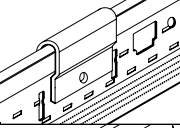
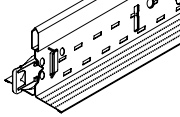
Main Beams														
Item Number	Length	Face Dimension	Profile Height	Duty Load	Fire Rated	Routes	Load Test Data (Lbs/LF)						Perspective	
							L/360 Simple Span			L/240 Simple Span				
							2'	3'	4'	2'	3'	4'		
HD8906 HD8906 G90 HD8906 HRC	144"	1-1/2"	1-11/16"	Heavy Duty	Yes	51 routes – starting 2-1/4" from each end†	95.5	35.8	18.76	139.85	52.24	28.14		
NEW HD8906 IIC	144"	1-1/2"	1-11/16"	Heavy Duty	Yes	51 routes – starting 2-1/4" from each end†	95.5	35.8	18.76	139.85	52.24	28.14		
NEW HD8906 10	120"	1-1/2"	1-11/16"	Heavy Duty	Yes	51 routes – starting 2-1/4" from each end†	95.5	35.8	18.76	139.85	52.24	28.14		

† Type "F" fixture compatible

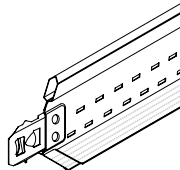
Cross Tees														
Item Number	Length	Face Dimension	Profile Height	Fire Rated	Routes	Load Test Data (Lbs/LF)						Perspective		
						L/360 Simple Span			L/240 Simple Span					
							72"			72"				
XL8965 XL8965 HRC	72"	1-1/2"	1-1/2"	Yes	6 routes – starting 24" from each end†	4.27			6.4					
							50"			50"				
XL8947P XL8947 PG90	50"	1-1/2"	1-1/2"	Yes	8 routes – starting 10" from each end†	13.0			19.5					
XL8945P XL8945 PG90 XL8945 HRC	48"	1-1/2"	1-1/2"	Yes	9 routes – center route and starting 10" from each end†			15.0			22.5			
XL8341	48"	15/16"	1-11/16"	Yes	3 routes – starting 12" from each end			16.59			24.89			
XL7341	48"	15/16"	1-11/16"	Yes	3 routes – starting 12" from each end			16.59			24.89			
XL7936 G90	36"	1-1/2"	1-1/2"	No	none		33.33			49.96				
XL8925 XL8925 G90	26"	1-1/2"	1-1/2"	Yes	2 routes – 12" from each end†	98.0			117.0					
XL8926 XL8926 G90	24"	1-1/2"	1-1/2"	Yes	3 routes – center route and 10" from each end†	129.0			158.0					
XL7918	14"	1-1/2"	1-1/2"	Yes	none†	71.5			107.0					

NOTE: All items available in High Recycled Content (HRC) as special order

† Type "F" fixture compatible

moldings

Moldings				
Item Number	Length	Description	Profile	Perspective
7858	144"	Reverse Angle Molding nominal 1-9/16" x 15/16"		
7838	120"	Unhemmed Channel Molding nominal 3/4" x 1-9/16" x 1-1/4"		
KAM10	120"	Knurled Angle Molding nominal 1-1/4" x 1-1/4" - 25g		
KAM12 KAM12G90 KAM12HRC	144"	Knurled Angle Molding nominal 1-1/4" x 1-1/4" - 25g		
KAM1510 KAM1512 KAM151020 KAM151020E	120" 144"	Knurled Angle Molding nominal 1-1/2" x 1-1/2" (KAM1510 & KAM1512 - 25g; KAM151020 - 20g; KAM151020EQ - 22g)		
KAM21020 KAM21025 KAM21020EQ	120" 144"	Knurled Angle Molding nominal 2" x 2" (20g) (KAM21020 - 20g; KAM21025 - 25g; KAM21020EQ 22g)		
LAM12 LAM12G90 LAM12HRC	144"	Locking Angle Molding nominal 1-1/4" x 1-1/4"		

NOTE: All items available in High Recycled Content (HRC) as special order.

DRYWALL Grid Systems

Moldings

Corrosion Prevention

Corrosion prevention is an essential factor in the economical utilization of galvanized sheet metal for ceiling suspension systems. Armstrong provides G40 for standard construction per ASTM C645. When conditions include exposure to extreme moisture and salt water, G90 is available per ASTM A653.

Drywall Transition Molding					
Material: Commercial-quality cold rolled hot dipped galvanized steel					
Item Number	Length/Item Description	Face Dimension	Flange	Profile Height	
7901	120" Shadow Reveal Molding	3/8" shadow reveal	9/16"	1-1/4"	
7902	120" Shadow Reveal Molding	3/8" shadow reveal	15/16"	1-1/4"	
7903	120" Inverted T Molding	1" inverted T	—	1-1/2"	
7904 7904PF*	120" Flush Transition Molding	15/16" horizontal	15/16"	1-1/4"	
7905 7905PF*	120" Flush Transition Molding	9/16" horizontal	9/16"	1-1/4"	
7906	120" "F" Molding	120" vertical transition	—	1-7/16"	
7907	120" Tegular Transition Molding	9/16" horizontal	9/16"	1-1/4"	
7908	120" Tegular Transition Molding	15/16" horizontal	15/16"	1-1/4"	

* 7904PF and 7905PF feature protective film on the acoustical wall angle flange for faster, easier finishing.

axiom transitions trim

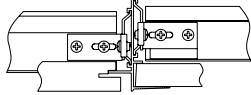
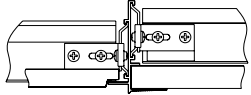
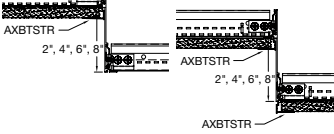
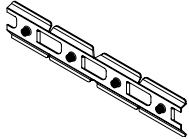
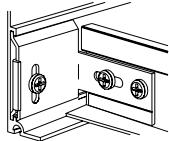
Axiom – Transitions Trim			
Material: Extruded aluminum, alloy 6063			
Item Number	Length/Item Description	Dimensions	
AXTRVSTR	Straight Transition for Vector®	120 x 2-9/16 x 1-11/16"	 <p>Axiom – Transitions with Vector panel to drywall perimeter (AXTRVSTR)</p>
AXTRTECUR	Curved Transition for Tegular	120 x 2-9/16 x 1-11/16"	 <p>Axiom – Transitions with Tegular panel to drywall perimeter (AXTRTESTR, AXTRTECUR)</p>
AXTR2STR	2" Straight Transition	120 x 2 x 1-1/2"	 <p>Acoustical-to-Drywall Drywall-to-Drywall</p>
AXTR2CUR	2" Curved Transition	120 x 2 x 1-1/2"	
AXTR4STR	4" Straight Transition	120 x 4 x 1-1/2"	
AXTR4CUR	4" Curved Transition	120 x 4 x 1-1/2"	
AXTR6STR	6" Straight Transition	120 x 6 x 1-1/2"	
AXTR6CUR	6" Curved Transition	120 x 6 x 1-1/2"	
AXTR8STR	8" Straight Transition	120 x 8 x 1-1/2"	
AXBTSTR	Drywall Bottom Trim	120 x 1-1/8 x 27/32"	
ACCESSORIES			
AX4SPICEB	Splice Plate	–	
AXTBC	T-Bar Connector Clip	–	



axiom drywall trim



Axiom One-Piece Drywall Trim *For use with 5/8" drywall only		
Material: Commercial-quality extruded aluminum alloy 6063		
Item Number	Length/Item Description	
AX1PC2STR	2.5" One-Piece Straight Drywall Trim	
AX1PC2CUR	2.5" One-Piece Curved Drywall Trim	
AX1PC4STR	4" One-Piece Straight Drywall Trim	
AX1PC4CUR	4" One-Piece Curved Drywall Trim	
AX1PC6STR	6" One-Piece Straight Drywall Trim	
AX1PC6CUR	6" One-Piece Curved Drywall Trim	

DRYWALL Grid Systems

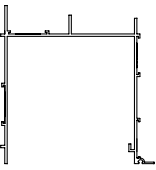
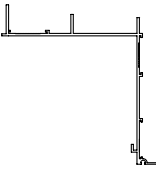
Axiom® – Building Perimeter System

axiom building perimeter system

Axiom – Building Perimeter Trim			
Material: Extruded aluminum			
Item Number	Length/Item Description	Dimensions	
AXP355	3-Sided Perimeter Pocket, Acoustical/Drywall Transition	5 x 5 x 5"	 <p>3-Sided Perimeter Pocket, Acoustical/Drywall Transition</p>
AXP355OSC	3-Sided Perimeter Pocket, Acoustical/Drywall Transition Outside Corner	12 x 5 x 12"	
AXP355ISC	3-Sided Perimeter Pocket, Acoustical/Drywall Transition Inside Corner	12 x 5 x 12"	
AXP355C	3-Sided Perimeter Pocket, Connection to Extension/Diffuser Piece	5 x 5 x 5"	
AXP355S	3-Sided Seismic Perimeter Pocket, Acoustical/Drywall Transition with 0.875 Flange	5 x 5 x 5"	
AXP355SOSC	3-Sided Seismic Perimeter Pocket, Acoustical/Drywall Transition with 0.875 Flange, Outside Corner	12 x 5 x 12"	
AXP355SISC	3-Sided Seismic Perimeter Pocket, Acoustical/Drywall Transition with 0.875 Flange, Inside Corner	12 x 5 x 12"	
AXP355COSC	3-Sided Perimeter Pocket, Connection to Extension/Diffuser Piece, Outside Corner	12 x 5 x 12"	
AXP355CISC	3-Sided Perimeter Pocket, Connection to Extension/Diffuser Piece, Inside Corner	12 x 5 x 12"	
AXP3552	3-Sided Perimeter Pocket, Acoustical/Drywall Transition, 2 Sides	5 x 5 x 5"	
AXP255	2-Sided Perimeter Pocket, Acoustical/Drywall Transition	5 x 5"	 <p>2-Sided Perimeter Pocket, Acoustical/Drywall Transition</p>
AXP255OSC	2-Sided Perimeter Pocket, Acoustical/Drywall Transition Outside Corner	12 x 5 x 12"	
AXP255ISC	2-Sided Perimeter Pocket, Acoustical/Drywall Transition Inside Corner	12 x 5 x 12"	
AXP255C	2-Sided Perimeter Pocket, Connection to Extension/Diffuser Piece	5 x 5"	
AXP236	2-Sided Perimeter Pocket, Acoustical/Drywall Transition – Narrow Width	3 x 6"	
AXP255COSC	2-Sided Perimeter Pocket, Connection to Extension/Diffuser Piece, Outside Corner	12 x 5 x 12"	
AXP255CISC	2-Sided Perimeter Pocket, Connection to Extension/Diffuser Piece, Inside Corner	12 x 5 x 12"	
Material: Extruded aluminum, alloy 6063			
AXPEP4	Axiom Perimeter Extension 4"	–	 <p>Perimeter Extension</p>
AXPEP6	Axiom Perimeter Extension 6"	–	
AXPEP8	Axiom Perimeter Extension 8"	–	
AXPEP4H	Axiom Perimeter Extension 4" Hook on Both Sides	–	
AXPEPS6	Axiom Seismic Perimeter 6", 0.875 Flange	–	

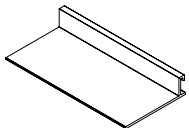
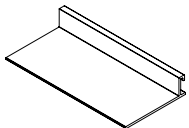
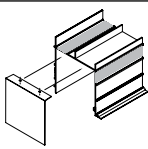
Axiom – Building Perimeter System (continued)			
Material: Extruded aluminum, alloy 6063			
Item Number	Length/Item Description	Dimensions	
AXPDFP4DT	Axiom Perimeter Diffuser Face Plate 4" Drywall Transition (Unslotted)	–	 <p>4" Diffuser Face Plate</p>
AXPDFP4DTSLA	Axiom Perimeter Diffuser Face Plate 4" Drywall Transition (Slotted 3/4" x 23" / 2-Slot Pattern)	–	
AXPDFP4DTSLB	Axiom Perimeter Diffuser Face Plate 4" Drywall Transition (Slotted 2-3/4" x 23" / 1-Slot Pattern)	–	
AXPDFP7DT	Axiom Perimeter Diffuser Face Plate 7" Drywall Transition (Unslotted)	–	 <p>7" Diffuser Face Plate</p>
AXPDFP7DTSLA	Axiom Perimeter Diffuser Face Plate 7" Drywall Transition (Slotted 3/4" x 23" / 2-Slot Pattern)	–	
AXPDFP7DTSLB	Axiom Perimeter Diffuser Face Plate 7" Drywall Transition (Slotted 2-3/4" x 23" / 1-Slot Pattern)	–	
AXPDFP4DT	Axiom Perimeter Diffuser Face Plate Drywall Transition 4" (Unslotted)	–	
AXPCC2	2" Axiom Building Perimeter Closure Clip	–	
AXPCC3	3" Axiom Building Perimeter Closure Clip	–	
AXPDFPS7	Axiom Seismic Perimeter Diffuser Face Plate 7" with 0.875 Flange (Unslotted) (120" x 7-13/16")	–	
AXPDFPS7SLA	Axiom Seismic Perimeter Diffuser Face Plate 7" with 0.875 Flange (Slotted 3/4" x 23" / 2-Slot Pattern) (120" x 7-13/16")	–	
AXPDFPS7SLB	Axiom Seismic Perimeter Diffuser Face Plate 7" with 0.875 Flange (Slotted 2-3/4" x 23" / 1-Slot Pattern) (120" x 7-13/16")	–	
AXCPCI	Axiom Building Perimeter End Plate	–	

Three-sided Perimeter Pocket with Face Plate

For more information, visit our website at armstrong.com/axiom or download BPCS-3911 Axiom Building Perimeter System Brochure or BPCS-3923 Axiom Building Perimeter Data Page.

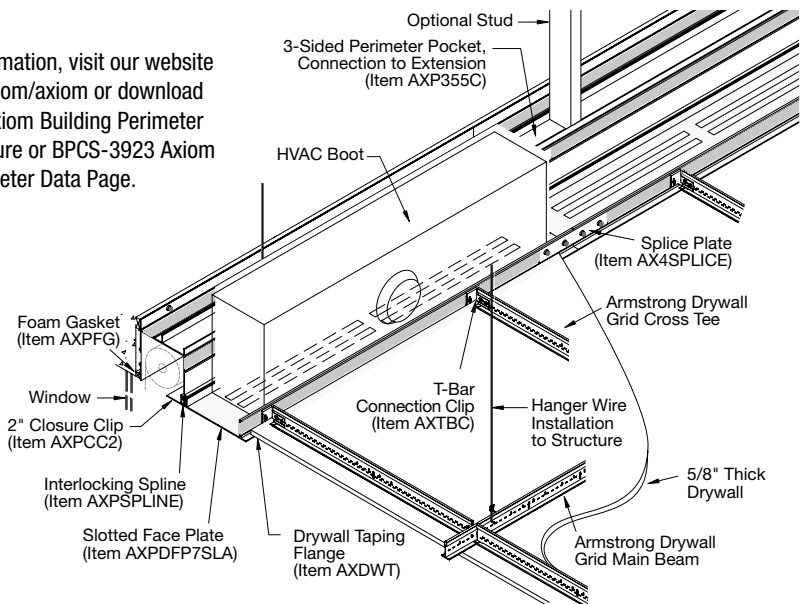

DRYWALL Grid Systems

Route Locations

Three-sided Perimeter Pocket with Diffuser Face Plate

route locations

HD8906 (HRC)/HD890610* **NEW**

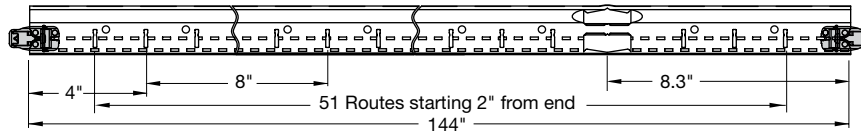

* HD890610 is 120" in length

NEW HD8906IIC

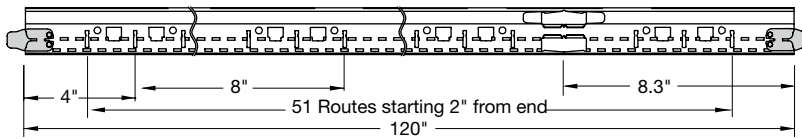

XL8965 (HRC) (Type "F" Compatible)

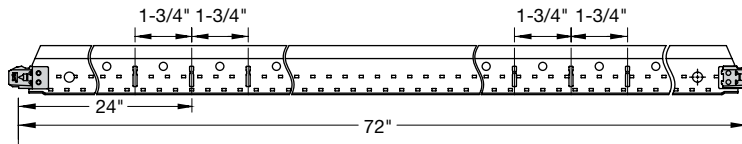

XL8947P (Type "F" Compatible)

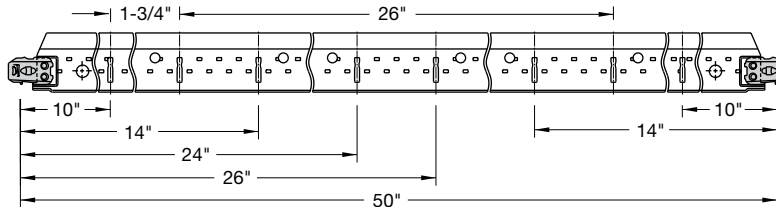

XL8945HRC/XL8945P (Type "F" Compatible)

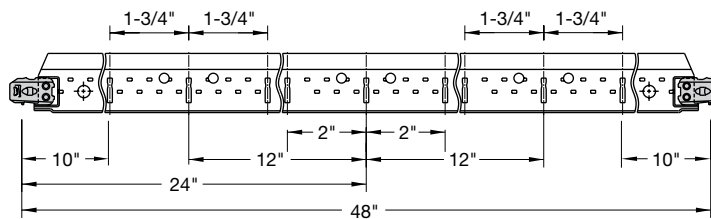

XL8341/XL7341

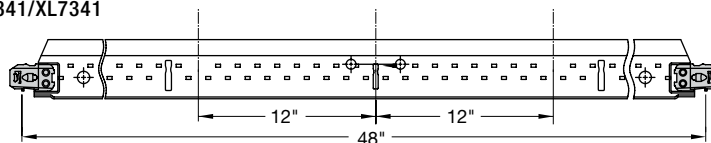

DRYWALL Grid Systems

Route Locations & Accessories

accessories

XL7936G90

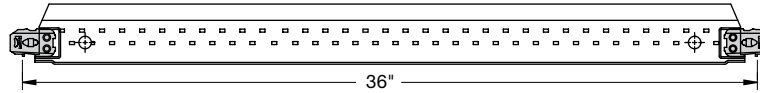

XL8925

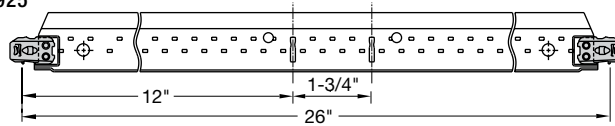

XL8926

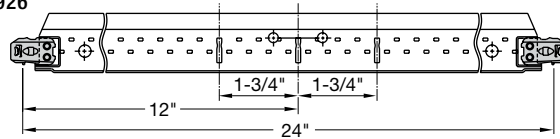

XL7918

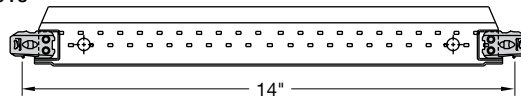

A variety of drywall grid accessories are available to provide problem-solving solutions that save time, labor, and money. For a complete list of accessories, request submittal BPCS-3082.				
Item Number	Quantity	Description	Perspective	Application
DWACS	100	Drywall Attachment Clip facilitates transition from drywall to acoustical ceiling; locks under bulb of grid section to prevent upward movement and provide secure attachment surface on one side of exposed grid.		
DW30C DW45C DW60C DW90C	250 250 250 250	30-, 45-, 60-, and 90-degree Drywall Angle Clips are used to create positive and secure angles for drywall and ceiling installations on either main beams or cross tees.		
TT10	30	Partition Top Trim is used to finish the top of a drywall partition for a continuous drywall/acoustical ceiling interface.		



Accessories (continued)				
Item Number	Quantity	Description	Perspective	Application
DW58LT	125	DW58LT – Transition Clip for 5/8" Drywall with Locking Tabs; facilitates transition from drywall to acoustical ceiling; one-sided hold down clip; eliminates need for drywall bead. Locking tabs provide secure location for DGS tees.		
DW50LT	125	DW50LT – Transition Clip for 1/2" Drywall with Locking Tabs; facilitates transition from drywall to acoustical ceiling; one-sided hold down clip; eliminates the need for a drywall bead. Locking tabs provide secure location for DGS tees.		
IIC	36	Impact Isolation Clip for use with HD8906IIC drywall grid main beam. Provides up to 8 points of IIC improvement to ensure your project meets IBC requirements.		
MBSC2	200	Main Beam Spacer Clip (2" in length) is used to space two parallel main beams 2" O.C. for air supply or return.		
GSC9 GSC12 GSC16	100 100 100	Adjustable Grid Spacer Clip is used to space two parallel main beams for light fixtures, air diffusers, etc.; allows for 1/4" adjustments with three different clips.		
XTAC	100	Cross Tee Adapter Clip – Used to attach field-cut cross tees to main beams.		
DDC	250	Double Drywall Clip is used to hang suspension system below existing 1-1/2" grid face, transferring weight directly to hanger wire; may be used to preserve the fire rating of an existing ceiling and to support heavy accessories; allows for double layer of 5/8" gypsum board.		
DLCC	250	Direct Load Ceiling Clip is used to hang suspension system below existing 15/16" grid face, transferring weight directly to hanger wire; may be used to preserve the fire rating of an existing ceiling and to support heavy accessories.		
DWC	250	Drywall Clip allows for a "second" ceiling to be installed below a drywall ceiling; attach through installed drywall to supporting structure.		
MBAC	70	Main Beam Adapter Clip attaches to web of suspension system section; provides larger surface for screw attachments; used as a hold down clip for thin material (metal or plastic lay-in panels); fastens drywall track to underside of exposed suspension system with lay-in panels, leaving suspension system face free of screw holes.		

DRYWALL Grid Systems

Hanging and Framing

System Framing

system framing

The grid system is comprised of main beams and cross tees that are suspended by hanger wires to the structural deck. Sections of main beams lock together end-to-end while cross tees span between the main beams. The ends of the main beams and cross tees rest on the wall channel or angle molding that run around the perimeter of the space.

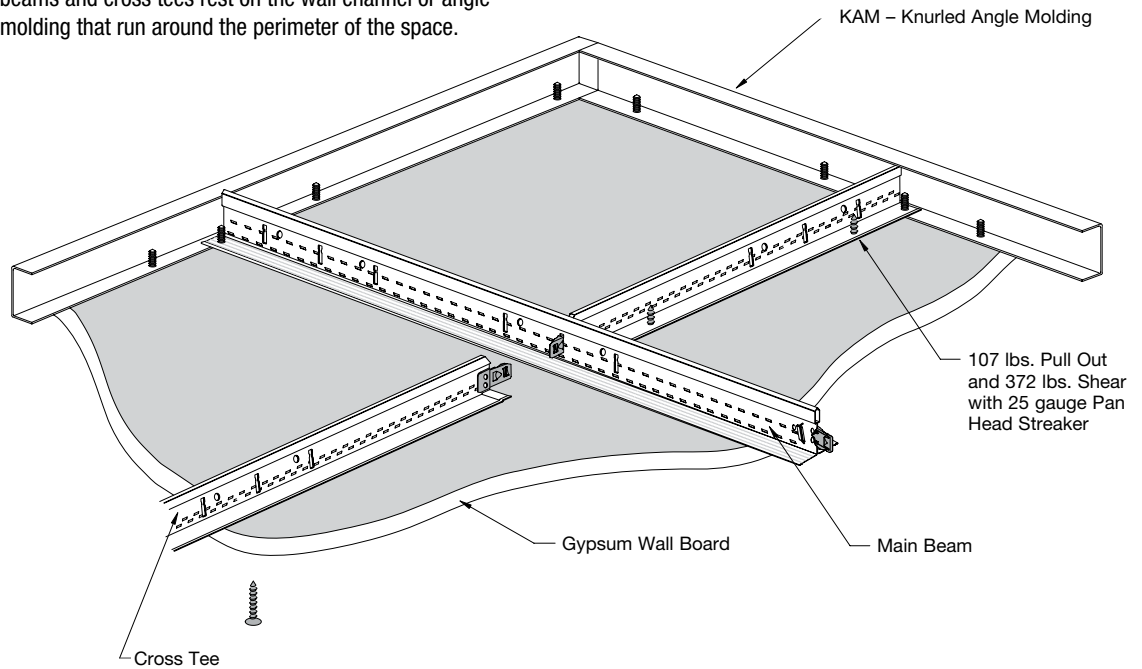

Squaring Up the System

Once you've hung your first two main beams and border cross tees, install two full cross tees between the main beams and in line with the first two border cross tees. To square up the system, simply measure across the diagonals of the opening. The measurements will be the same if the grid is square. If the grid is not square, shorten one of the main beams until the diagonals are equal.

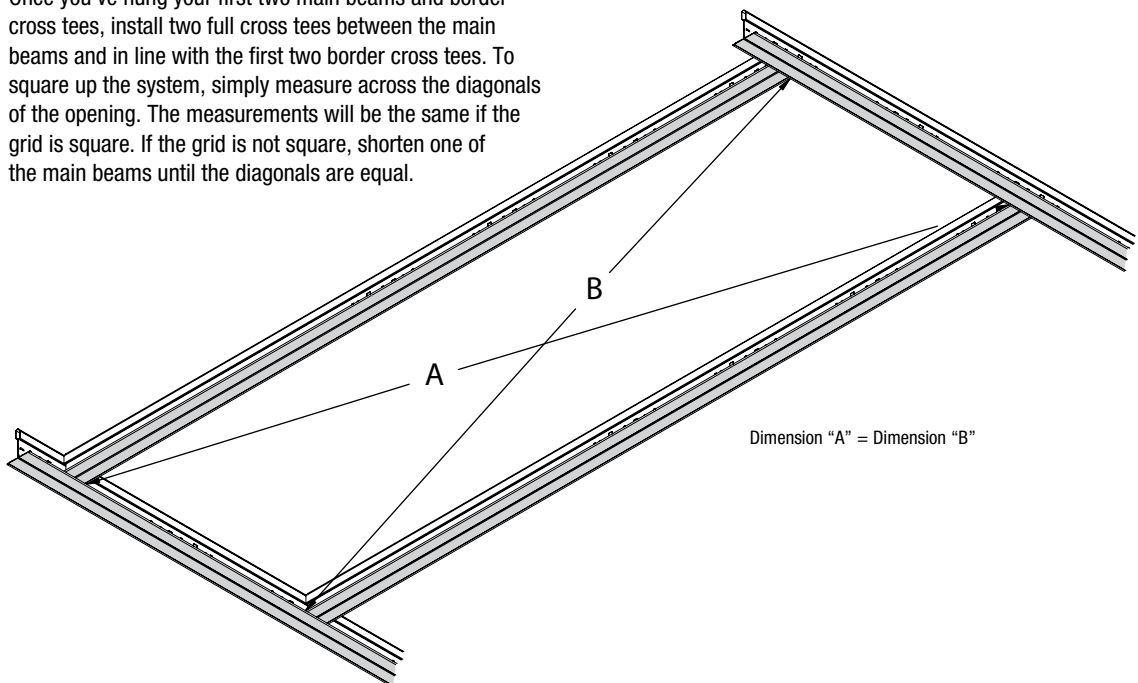

DRYWALL Grid Systems

Hanging and Framing

Type "F" Fixtures

Type "F" fixtures, access panels, and air diffusers require a full 12", 24", or 48" opening dimension. The Armstrong Drywall Grid System main beams and cross tees have additional routes in the web to accommodate this larger opening for type "F" fixtures. Using our 14", 26", 50", and 72" cross tees, type "F" fixtures fit perfectly without field cutting or special accessories.

When installing type "F" fixtures **parallel** to the main beams, use a 72" and 48" cross tee for easy placement of fixtures without field modifications.

When installing fixtures **perpendicular** to the main beams, use our 72" cross tees for virtually limitless fixture placement.

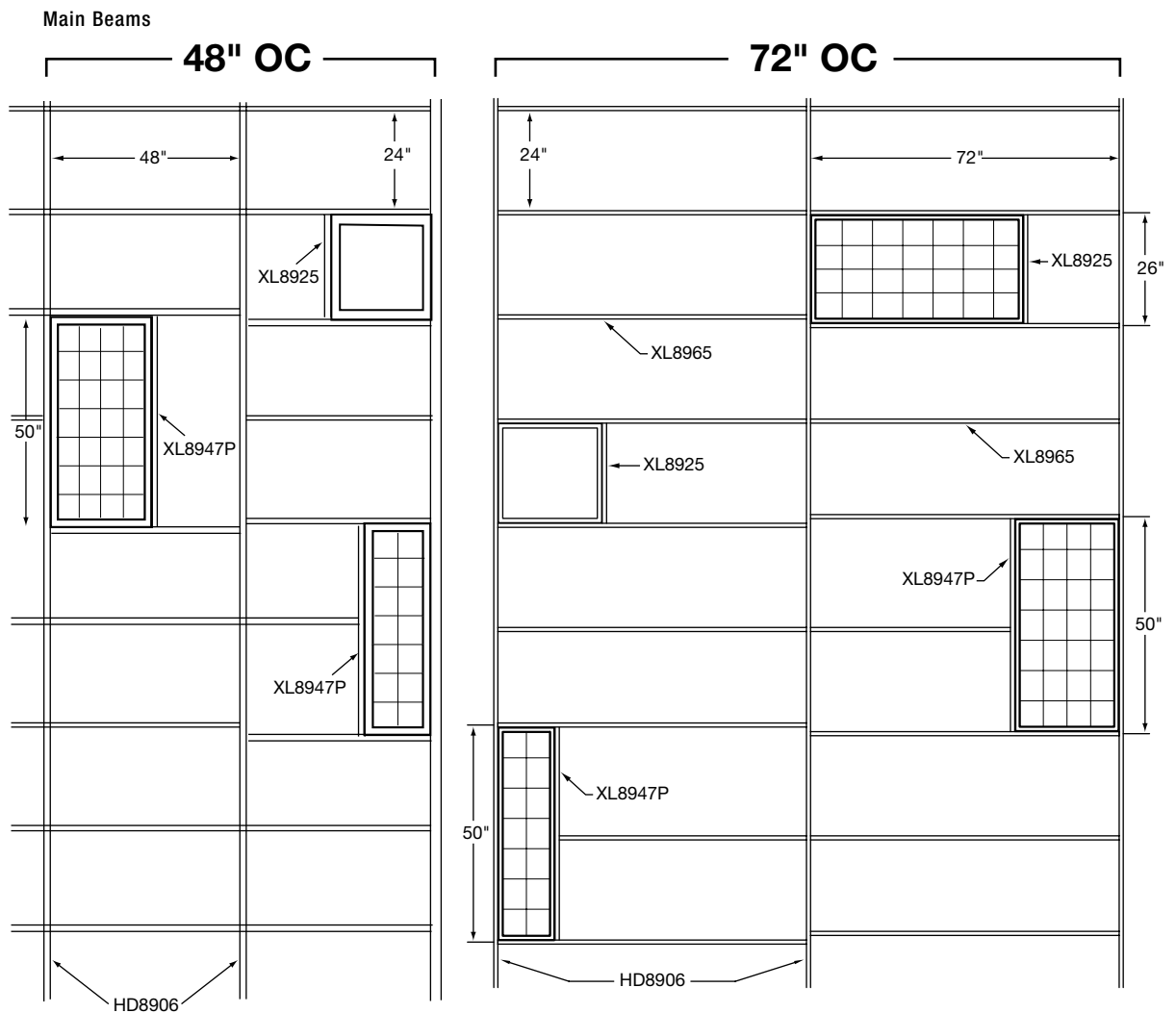

DRYWALL Grid Systems

Suspended Drywall Grid System Details

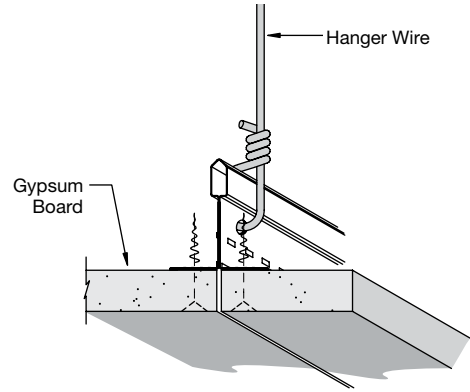
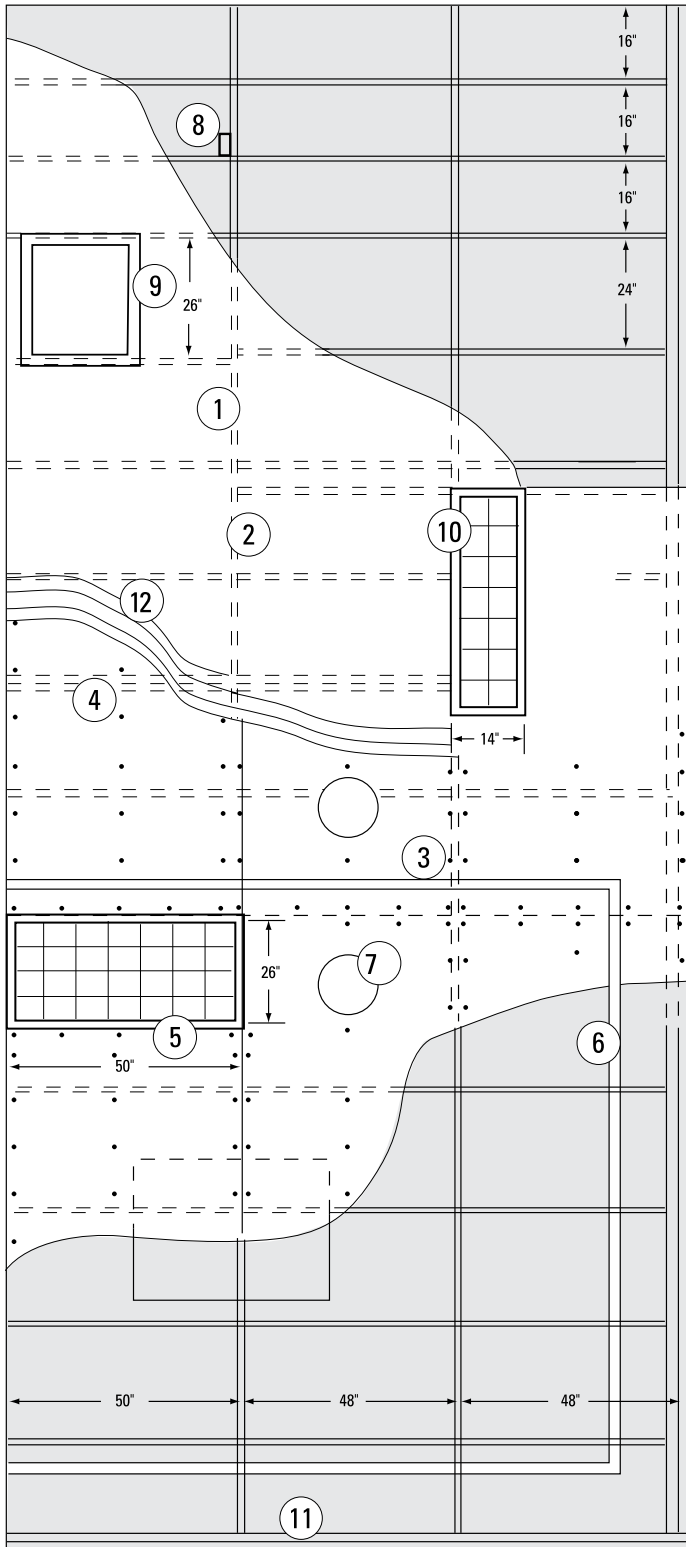

1 Butt Joint

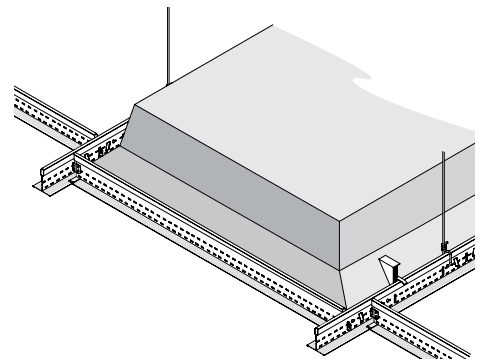

5 Type "F" Fixture

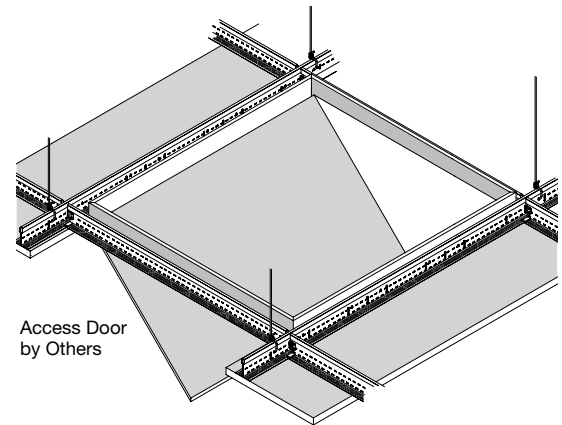

9 Access Door

DRYWALL Grid Systems

Suspended Drywall Grid System Details

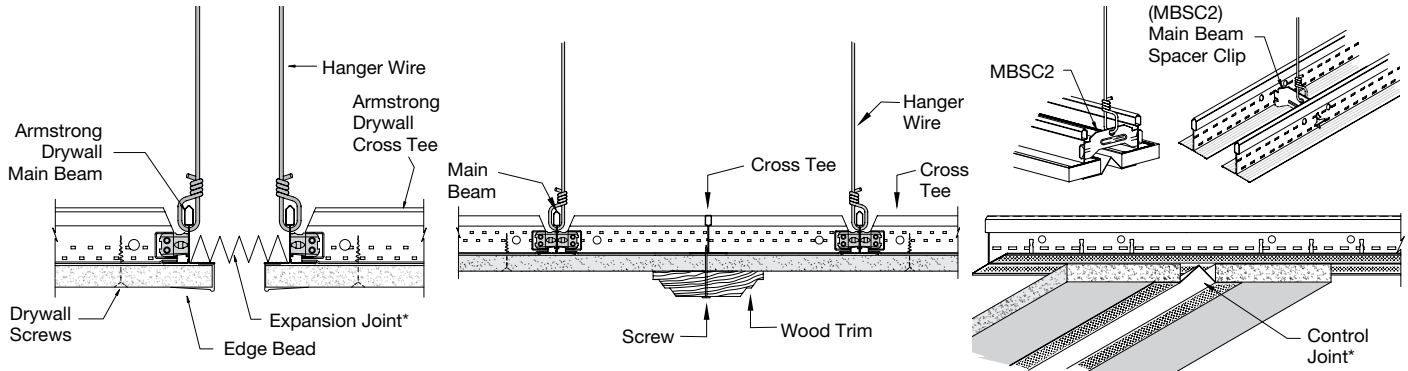

2 Expansion Joint*

3 Wood Trim

4 Control Joint

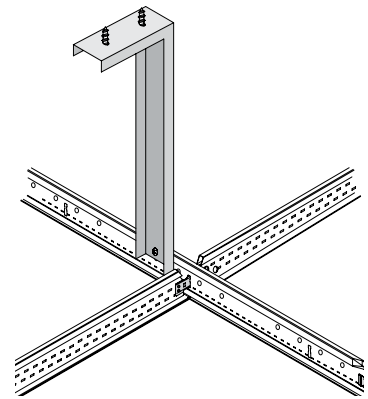
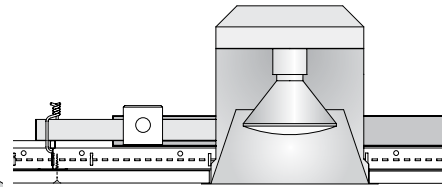
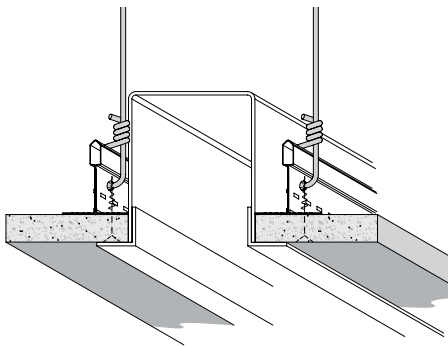

6 Air Bar

7 High Hat Fixture

8 Vertical Brace

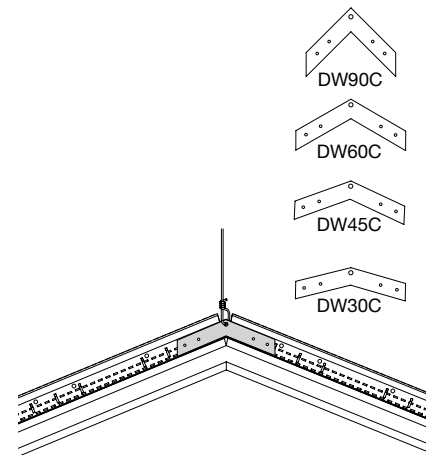
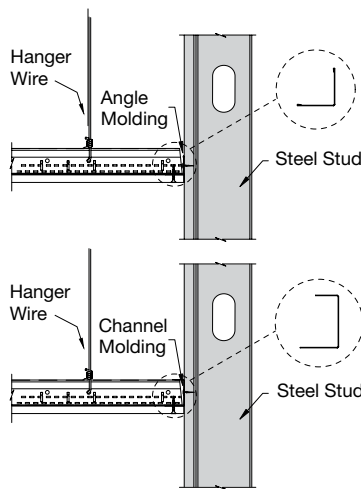
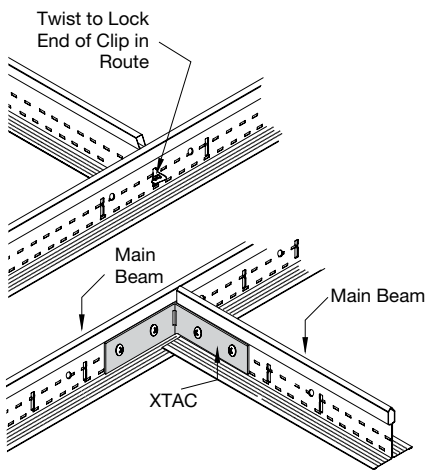

10 Securing a Single Cross Tee

11 Channel and Angle Molding

12 Angle Clip

DRYWALL Grid Systems

Suspended Drywall Grid System Details

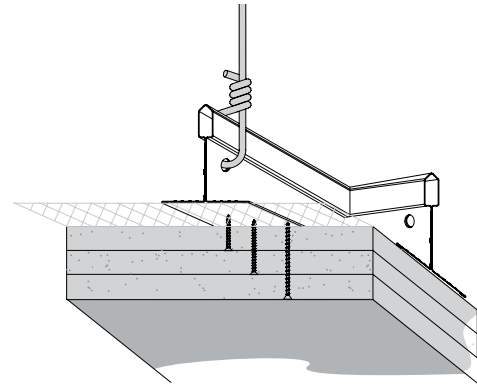
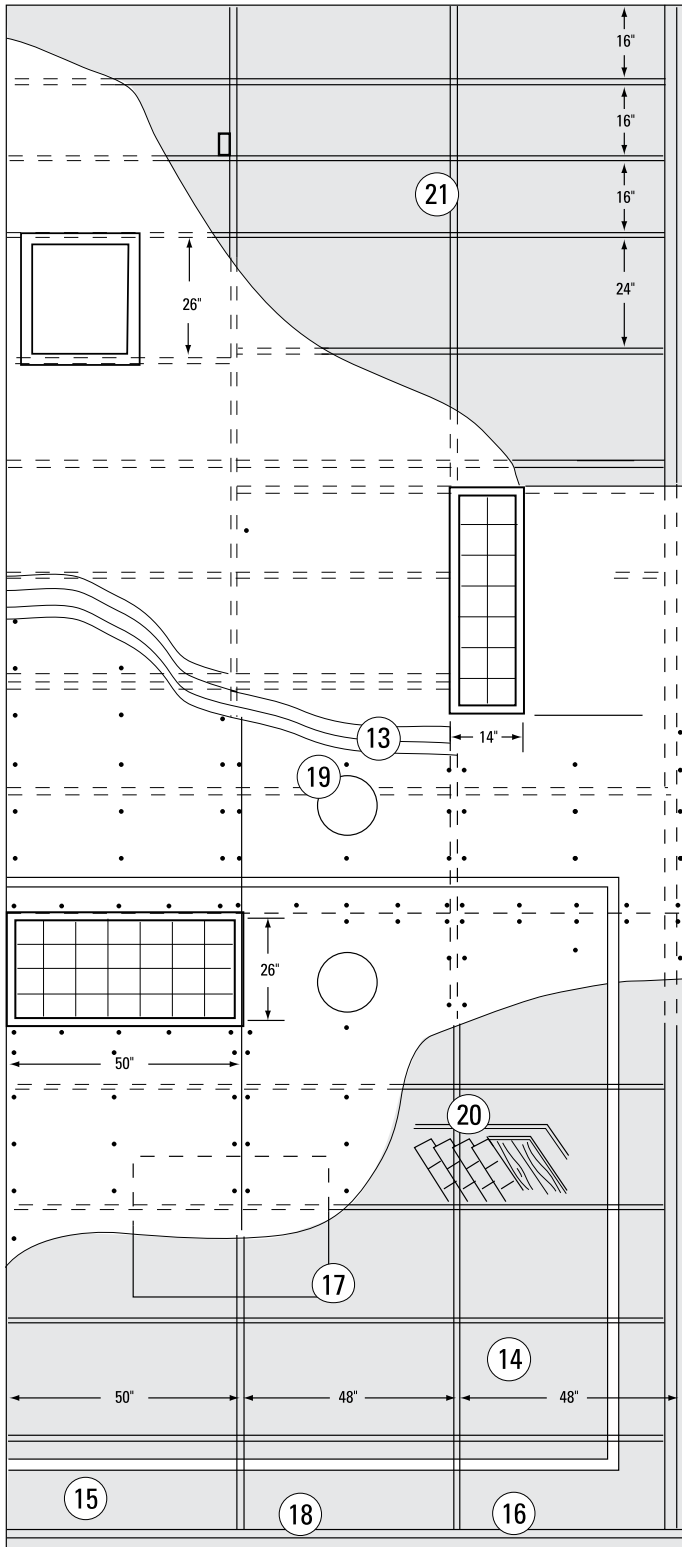

13 Triple Layer with Security Lath

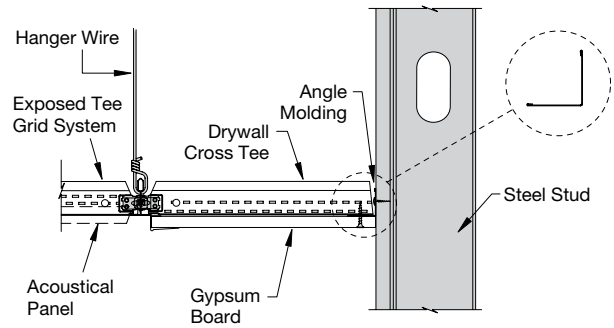

17 Transition

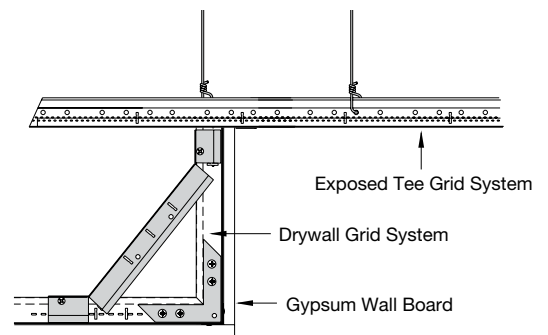

NOTE: Brace as required by code

20 Drywall Vertical

DRYWALL Grid Systems

Suspended Drywall Grid System Details

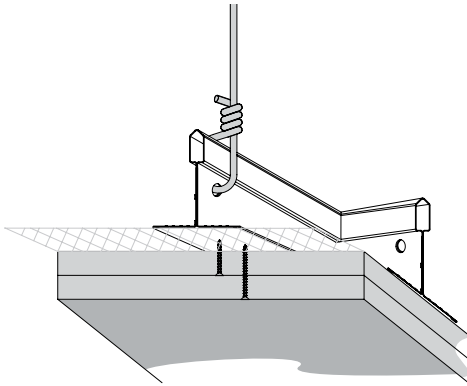

14 Double Layer with Security Lath

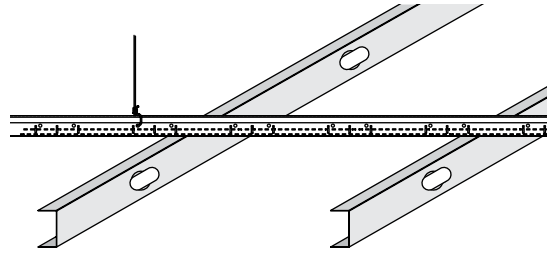

15 Main Beam Stabilizer

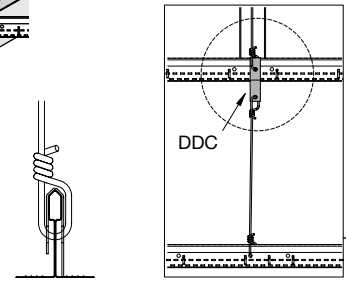

16 Double Hung Ceiling

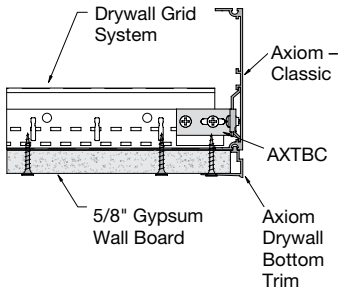

18 Axiom® Perimeter Trim

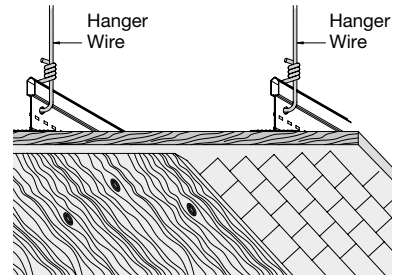
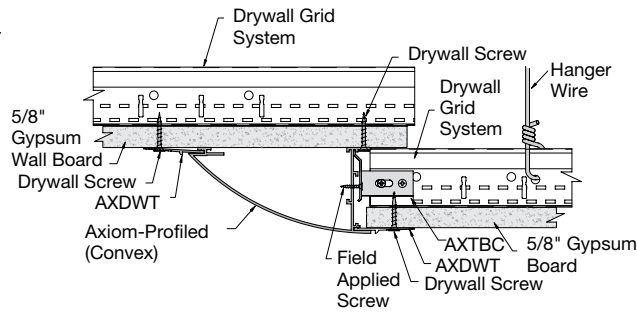

19 Alternate Finishes

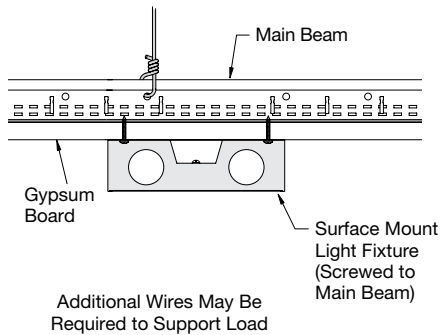

21 Surface Mount Fixture

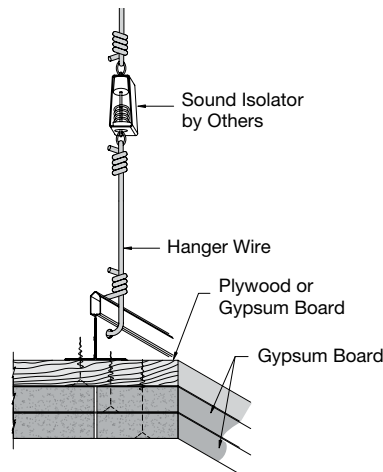

22 Triple Layer with Sound Isolators

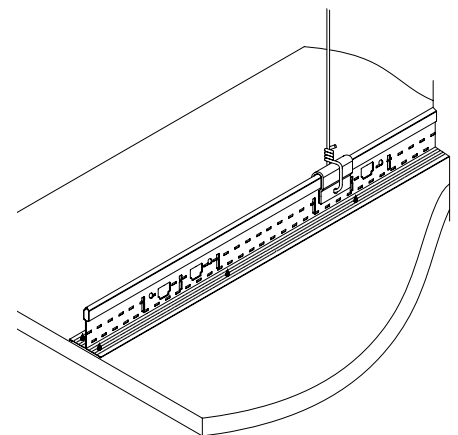

NEW **23** HD8906 with IIC Clip

Wire Loading

wire loading

9 Gauge Wire Breaking Strength and Technical Data

9 Gauge Wire
Diameter .148"
Galvanized Steel

**645 lbs.
Maximum Safe
Wire Load**

3 Turns in 3"
Per ASTM C636

**450 lbs. Pullout –
Hanger Wire Hole**

12 Gauge Wire Breaking Strength and Technical Data

12 Gauge Wire
Diameter .105"
Galvanized Steel

**275 lbs.
Maximum Safe
Wire Load**

3 Turns in 3"
Per ASTM C636

**500 lbs. Pullout –
Hanger Wire Hole**

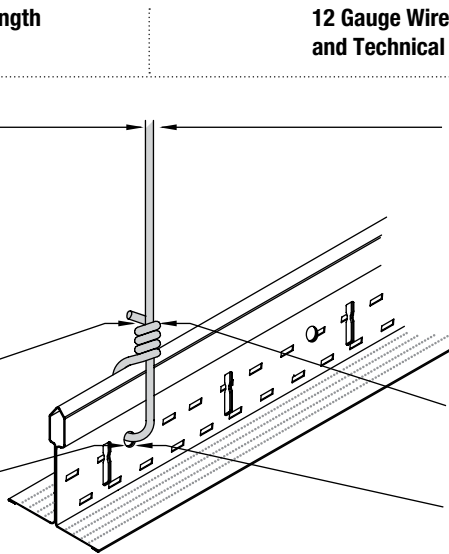

Counter Splayed Wires

Objects in the plenum may obstruct placement of vertical hanger wires and require splayed wires to support the load. When this occurs, a second counter splayed wire must be added. Install counter splayed wires at an angle equal and opposite to the first wire, but not greater than 45° from vertical. The load capacity of the main beam remains unchanged (refer to ASTM C636).

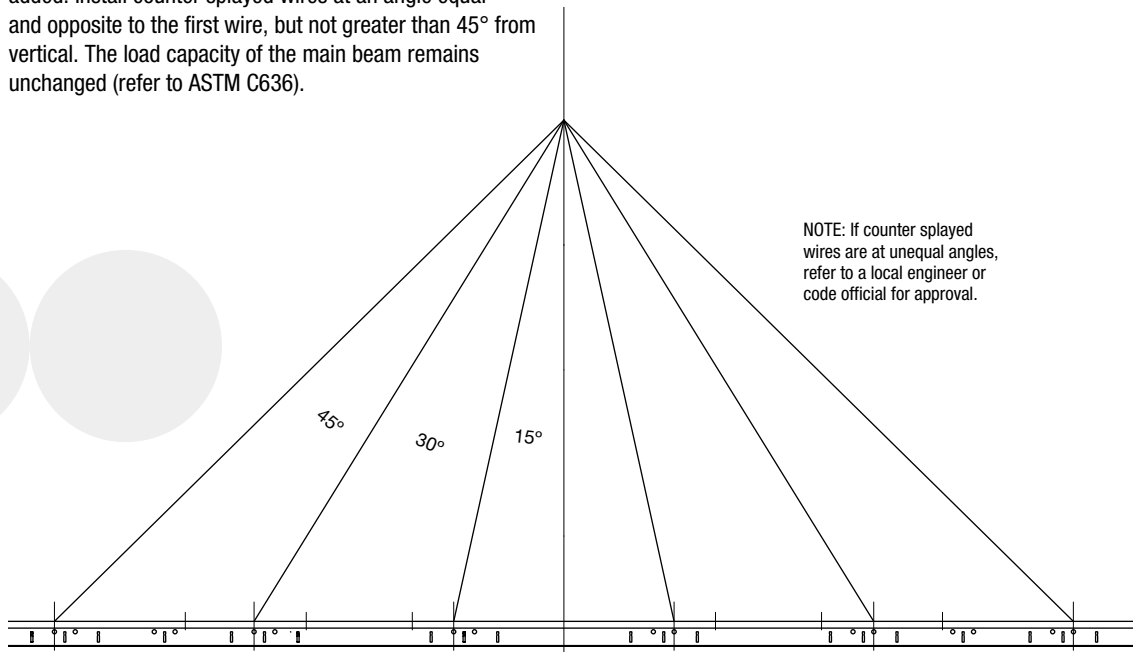

Yoke Wire Hung Ceilings

yoke wire

Another method to install hanger wires around an object in the plenum is to utilize a single or double yoke wire technique.

Rule: To form the 45-degree angle, the vertical location of the tension ring is always half the distance of the span at the structure.

Single Yoke

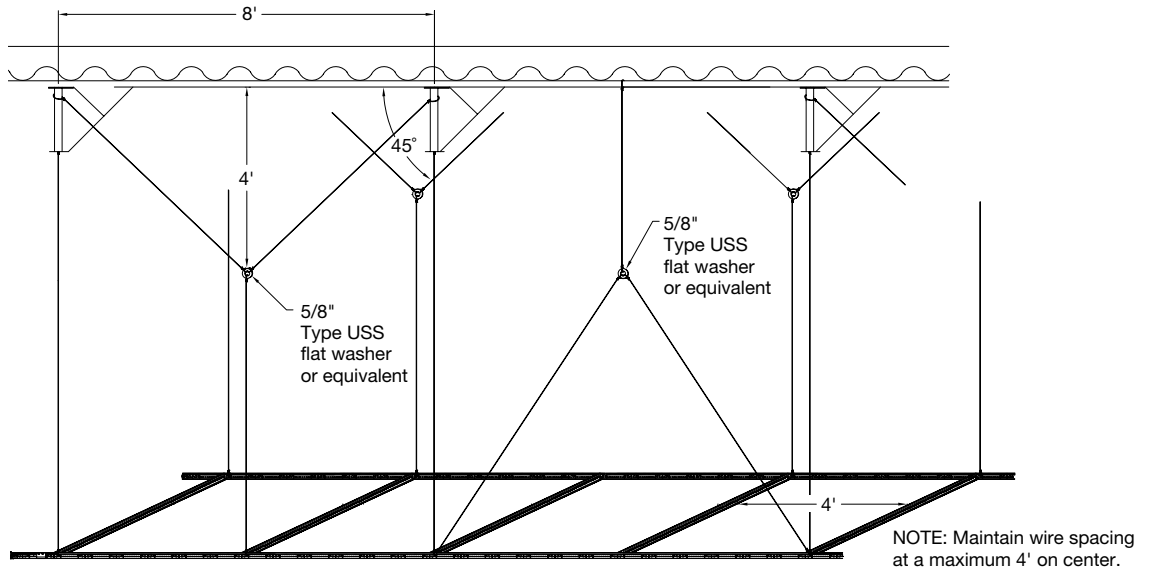

Double Yoke

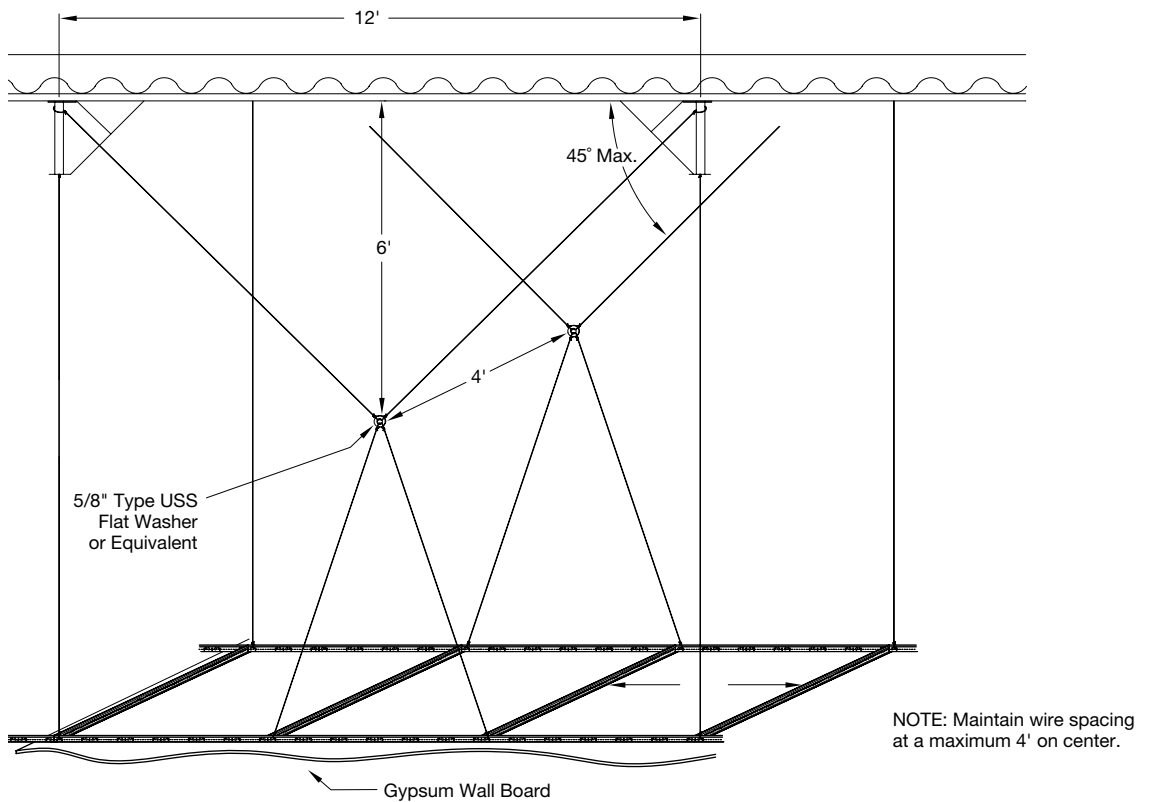

Trapeze Supported Loads

trapeze supported loads

Installing a trapeze is a technique to support multiple hanger wires under obstructions, such as trunk lines, cable trays, or other objects in the plenum. In some cases, the trapeze may affect the ceiling height and must be kept small. In other cases, steel studs may be used to span the distance required.

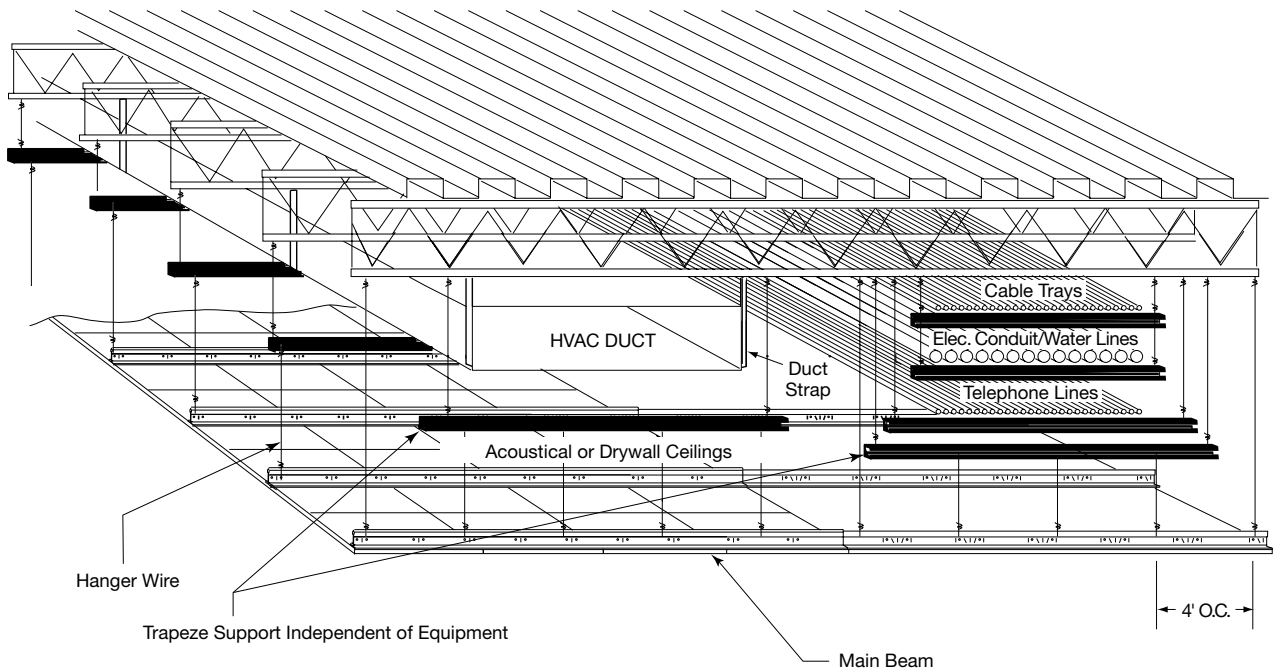

DRYWALL Grid Systems

Hanging and Framing

Double Hung Ceilings

A suspended ceiling not only carries the load of the applied finish, but can also act as a load carrying structure or membrane that supports another ceiling at a lower level. The DDC clip is used at hanger wire locations to allow for connecting the second and even third ceiling. This method of hanging and framing is used in multi-layer ceilings with long vertical drops – eliminating the use of long stud drops.

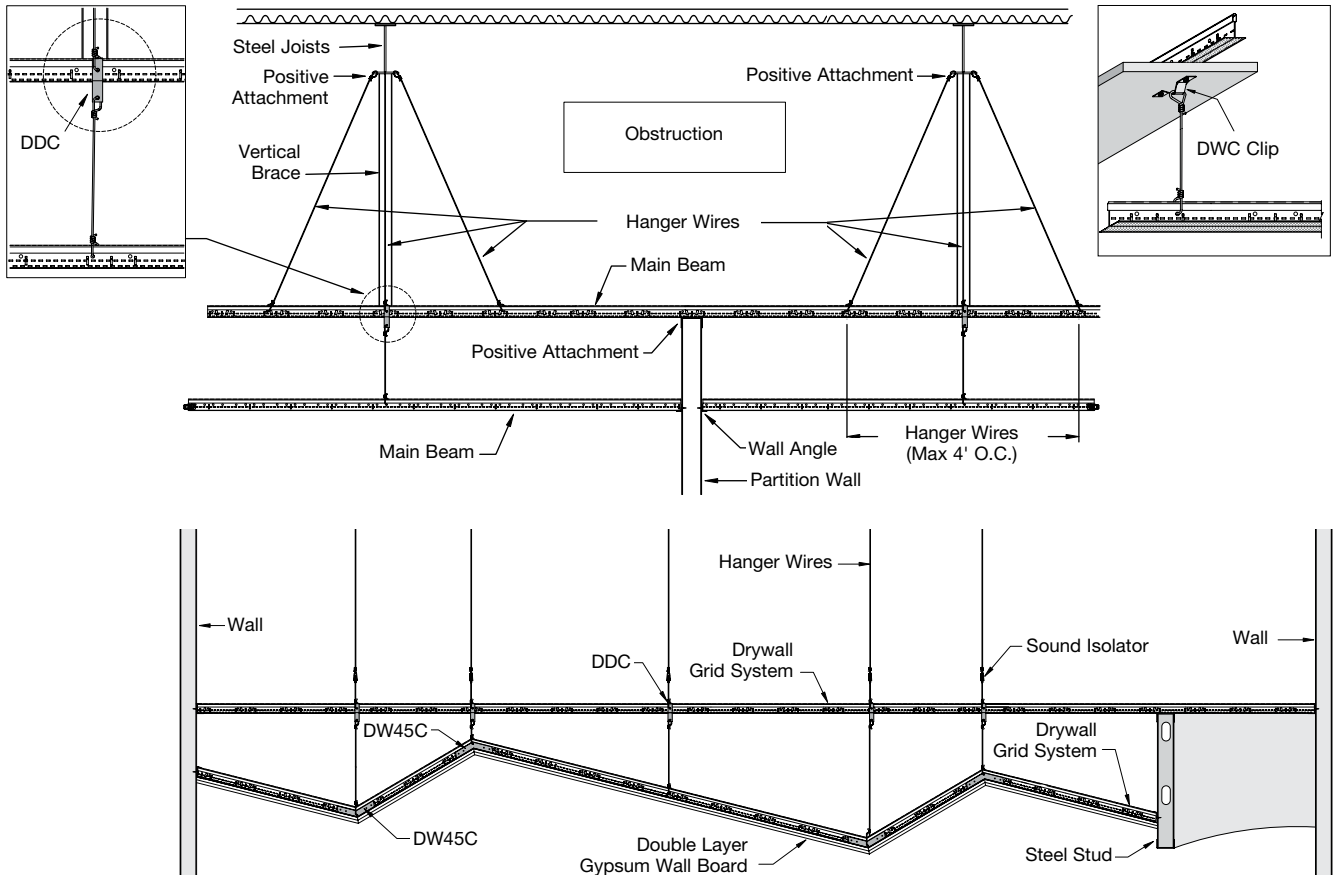

Gusset Hung Ceiling

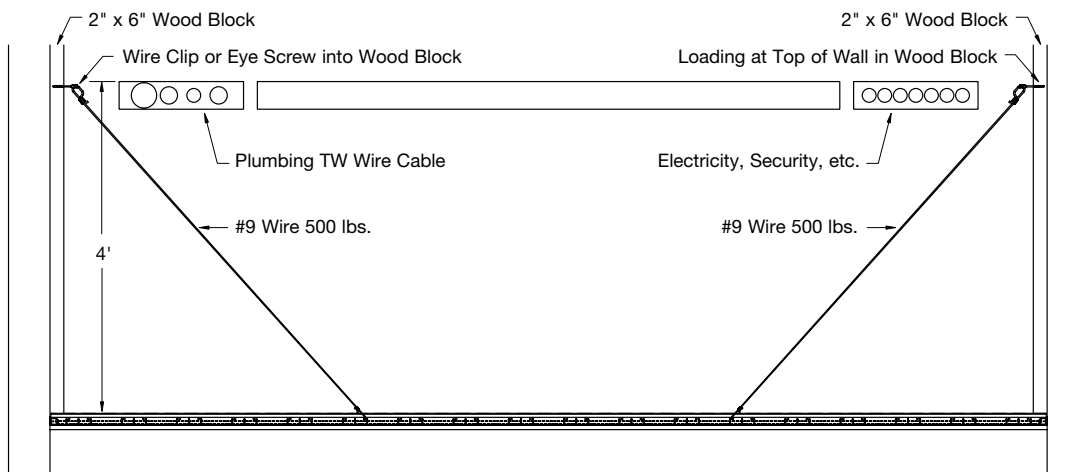

DRYWALL Grid Systems

Hanging and Framing

Triple Hung Ceilings

ceiling type

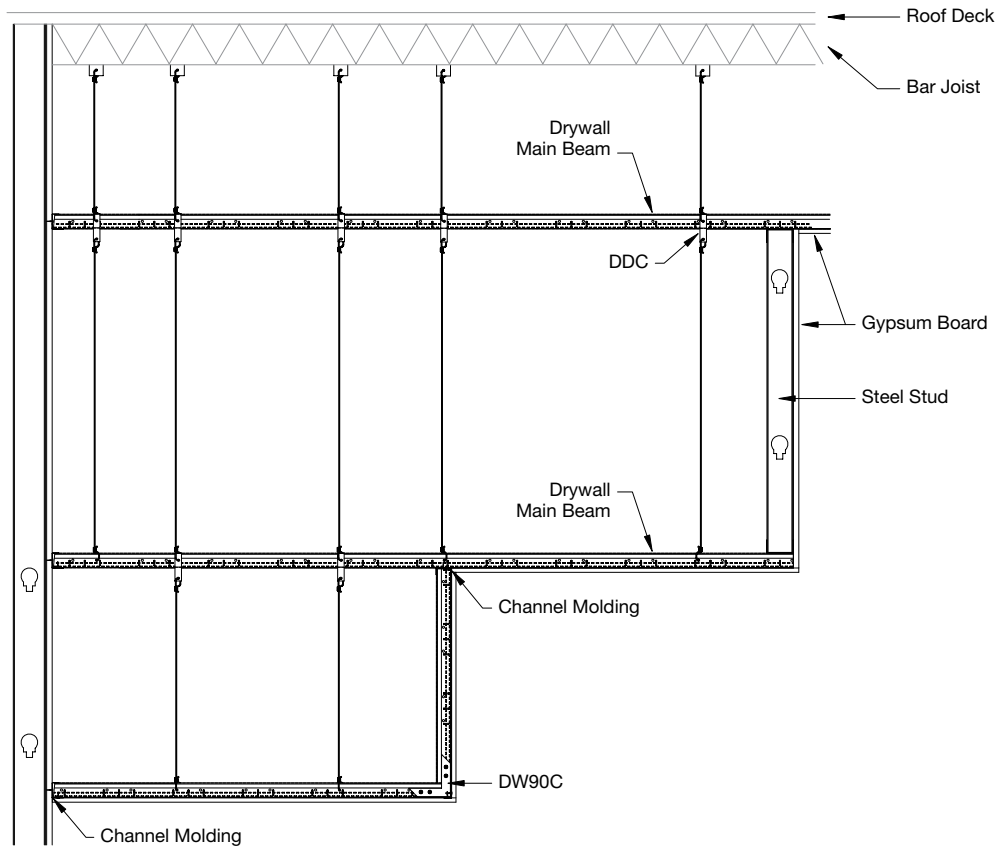
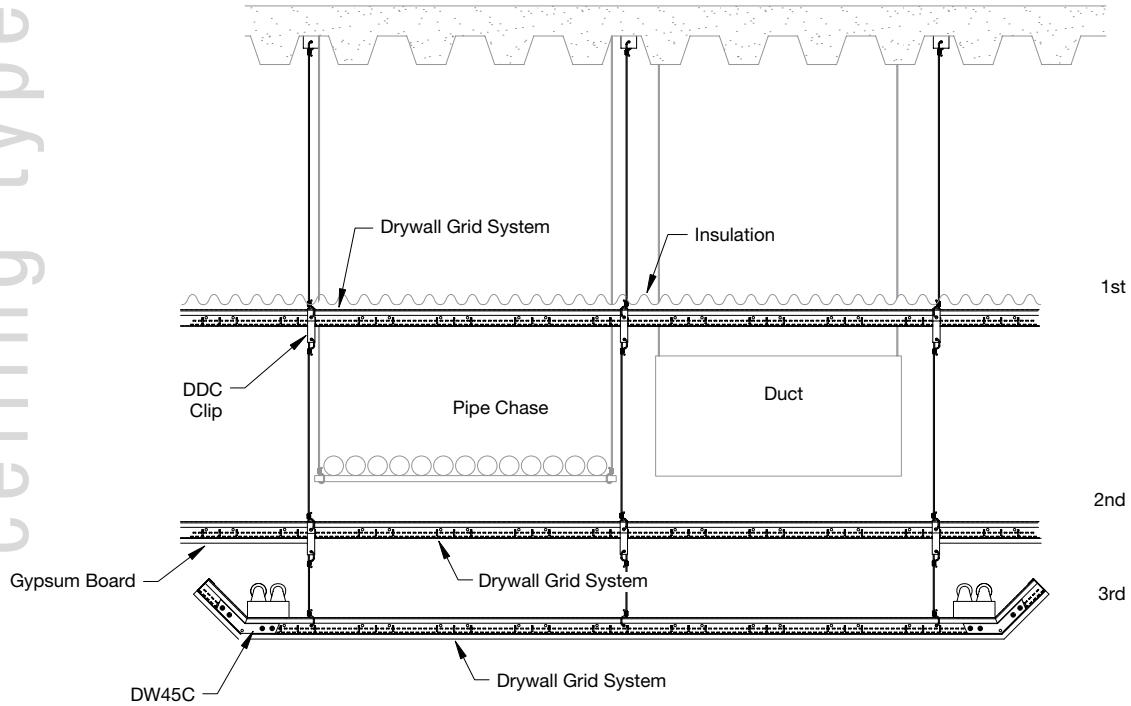

DRYWALL Grid Systems

Hanging and Framing

Exterior Wind Load Ceiling Design For North America												
Plenum Height (ft.-in.)	Design Wind Velocity (MPH)	Design Wind Pressure (PSF)	Compression Post Size (Inch)	Compression Post Gauge (Ga. No.)	Sheathing Membrane Substrate 5/8" Drywall Sheet Densglass Gold G-P	Compression Post Spacing (ft.-in.)	Main Beam Spacing (Inch)	Cross Tee Spacing (Inch)	Hanger Wire Spacing (ft.-in.)	Cross Tee Length (Feet)	Compression Post Design Load (Lbs.)	
0 ↓ 6' ***	15	5.07	2-1/2" CWN	20	5/8" G.P. Densglass & 1/4"-3/8" EIFS	4' - 2"	48"	16"	4'	4'	18	
	30	2.03	2-1/2" CWN	20	5/8" G.P. Densglass & 1/4"-3/8" EIFS	4' - 2"	48"	16"	4'	4'	49	
	45	4.56	2-1/2" CWN	20	5/8" G.P. Densglass & 1/4"-3/8" EIFS	3' - 6"	48"	16"	4'	4'	96	
	60	8.1	2-1/2" CWN	20	5/8" G.P. Densglass & 1/4"-3/8" EIFS	3' - 6"	36"	16"	4'	3'	125	
	90	18.24	2-1/2" CWN	20	5/8" G.P. Densglass & 1/4"-3/8" EIFS	3' - 4"	24"	16"	3'	2'	178	
	120	32.43	2-1/2" CWN	20	5/8" G.P. Densglass & 1/4"-3/8" EIFS	2' - 8"	24"	16"	2' - 6"	2'	266	
	140	44.14	2-1/2" CWN	18	5/8" G.P. Densglass & 1/4"-3/8" EIFS	2' - 4"	24"	16"	2' - 6"	2'	331	
	172	75	2-1/2" CSJ	18	See NOA 12-0314.05 Design	2'	24"	16"	2'	2'	445	
	172	75	2-1/2" CSJ	18	See NOA 12-0314.04 Design	2' - 6"	36"	16"	2' - 6"	3'	565	
6' 1" ↓ 10' 3" ****	15	5.07	2-1/2" CSJ	18	5/8" G.P. Densglass & 1/4"-3/8" EIFS	4' - 2"	48"	16"	4'	4'	18	
	30	2.03	2-1/2" CSJ	18	5/8" G.P. Densglass & 1/4"-3/8" EIFS	3'-10"	48"	16"	4'	4'	49	
	45	4.56	2-1/2" CSJ	18	5/8" G.P. Densglass & 1/4"-3/8" EIFS	3' - 6"	48"	16"	4'	4'	96	
	60	8.1	2-1/2" CSJ	18	5/8" G.P. Densglass & 1/4"-3/8" EIFS	3' - 6"	36"	16"	4'	3'	125	
	90	18.24	2-1/2" CSJ	18	5/8" G.P. Densglass & 1/4"-3/8" EIFS	3' - 4"	36"	16"	3'	2'	178	
	120	32.43	2-1/2" CSJ	18	5/8" G.P. Densglass & 1/4"-3/8" EIFS	2' - 8"	24"	16"	2' - 6"	2'	266	
	140	44.14	2-1/2" CSJ	18	5/8" G.P. Densglass & 1/4"-3/8" EIFS	2' - 4"	24"	16"	2' - 6"	2'	331	
	172	75	2-1/2" CSJ	18	See NOA 12-0314.05 Design	2'	24"	16"	2'	2'	445	
	172	75	2-1/2" CSJ	18	See NOA 12-0314.04 Design	2' - 6"	36"	16"	2' - 6"	3'	565	
10' 4" ↓ 15' 0" ****	*15	5.07	2-1/2" CSJ	18	5/8" G.P. Densglass & 1/4"-3/8" EIFS	4' - 2"	48"	16"	4'	4'	18	
	*30	2.03	2-1/2" CSJ	18	5/8" G.P. Densglass & 1/4"-3/8" EIFS	3'-10"	48"	16"	4'	4'	49	
	*45	4.56	2-1/2" CSJ	18	5/8" G.P. Densglass & 1/4"-3/8" EIFS	3' - 6"	48"	16"	4'	4'	96	
	*60	8.1	2-1/2" CSJ	18	5/8" G.P. Densglass & 1/4"-3/8" EIFS	3' - 6"	36"	16"	4'	3'	125	
	*90	18.24	2-1/2" CSJ	18	5/8" G.P. Densglass & 1/4"-3/8" EIFS	3' - 4"	36"	16"	3'	2'	178	
	*120	32.43	2-1/2" CSJ	18	5/8" G.P. Densglass & 1/4"-3/8" EIFS	2' - 8"	24"	16"	2' - 6"	2'	266	
	*140	44.14	2-1/2" CSJ	18	5/8" G.P. Densglass & 1/4"-3/8" EIFS	2' - 4"	24"	16"	2' - 6"	2'	331	
	*172	75	2-1/2" CSJ	18	See NOA 12-0314.05 Design	2'	24"	16"	2'	2'	445	
	*172	75	2-1/2" CSJ	18	See NOA 12-0314.04 Design	2' - 6"	36"	16"	2' - 6"	3'	565	
15' 1" ↓ 20' 0" ****	**15	5.07	3-5/8" CSJ	18	5/8" G.P. Densglass & 1/4"-3/8" EIFS	4' - 2"	48"	16"	4'	4'	18	
	**30	2.03	3-5/8" CSJ	18	5/8" G.P. Densglass & 1/4"-3/8" EIFS	3' - 10"	48"	16"	4'	4'	49	
	**45	4.56	3-5/8" CSJ	18	5/8" G.P. Densglass & 1/4"-3/8" EIFS	3' - 6"	48"	16"	4'	4'	96	
	**60	8.1	3-5/8" CSJ	18	5/8" G.P. Densglass & 1/4"-3/8" EIFS	3' - 6"	36"	16"	4'	3'	125	
	**90	18.24	3-5/8" CSJ	18	5/8" G.P. Densglass & 1/4"-3/8" EIFS	3' - 4"	36"	16"	3'	2'	178	
	**120	32.43	3-5/8" CSJ	18	5/8" G.P. Densglass & 1/4"-3/8" EIFS	2' - 8"	24"	16"	2' - 6"	2'	266	
	**140	44.14	3-5/8" CSJ	18	5/8" G.P. Densglass & 1/4"-3/8" EIFS	2' - 4"	24"	16"	2' - 6"	2'	331	
	**172	75	3-5/8" CSJ	18	See NOA 12-0314.05 Design	2'	24"	16"	2'	2'	445	
	**172	75	3-5/8" CSJ	18	See NOA 12-0314.04 Design	2' - 6"	36"	16"	2' - 6"	3'	565	

* 1-1/2" 16 gauge U-Channel Bridging required at mid span for 10'4" up to 15'0"

** 1-1/2" 16 gauge U-Channel Bridging required at one-third points for 15'1" up to 20'0"

*** Compression Post and Ceiling System tested at the plenum design depth shown here for positive and negative wind speed pressure loads as listed

**** Compression Post Assemblies at this plenum design depth calculated by Dietrich Design Group

NOTE: For building heights over 20 feet, refer to ASCE 7-10 Chapter 6 Wind Loads

DRYWALL Grid Systems

Hanging and Framing

fire resistant

UL Fire Resistive Designs							
Deck Construction Type	UL Design Number	Concrete Thickness	# Drywall Layers	Minimum Drywall Thickness	Maximum Fixture Penetration (Ft ² /100 Ft ²)	Maximum Duct Penetration (In ² /100 Ft ²)	Drywall Grid System
FLOOR/CEILING DRYWALL ASSEMBLIES							
Concrete on Composite Flat Cellular, Fluted, or Blend Deck							
2-Hour	D501	2-1/2"	1	5/8"	None	None	DFR 8000
	D502**	2-1/2"	1	5/8"	24	144	DFR 8000
Concrete on Metal Lath, Corrugated, and Ribbed Deck							
3-Hour	G523**	3"	1	5/8"	24	144	DFR 8000
	G524***	3-1/2", 3-3/4"	1	1/2"	None	113	DFR 8000
	G529	3-1/4"	1	1/2"	24	57	DFR 8000
	G529	2-3/4"	1	5/8"	24	57	DFR 8000
2-Hour	G523	2-1/2"	1	1/2" or 5/8"**	24	144	DFR 8000
	G524***	3-1/2", 3-3/4"	1	1/2"	None	113	DFR 8000
	G527	2-1/2"	1	1/2" or 5/8"**	None	None	DFR 8000
	G529	2-1/2"	1	1/2"	24	57	DFR 8000
1-1/2-Hour	G528	2-1/2"	1	1/2" or 5/8"**	None	None	DFR 8000
	G524	2-3/4" – 3"	1	1/2" or 5/8"	***	***	DFR 8000
Precast Concrete Slab							
3-Hour	J502	2-3/4"	1	5/8"	None	None	DFR 8000
2-Hour	J502	2"	1	5/8"	None	None	DFR 8000
WOOD DECK/CEILING DRYWALL ASSEMBLIES							
Plywood 2 x 10 Wood Joists							
1-Hour	L502	NA	1	1/2"	None	None	DFR 8000
	L513	NA	1	5/8"	None	None	DFR 8000
	L515	NA	1	1/2"	None	None	DFR 8000
	L525	NA	1	1/2" or 5/8"**	24	57	DFR 8000
	L526**	NA	1	5/8"	24	114	DFR 8000
Plywood (2) 2 x 10 or (1) 4 x 10 Wood Joists							
1-Hour	L508	NA	1	5/8"	None	None	DFR 8000
Plywood with Wood Trusses							
1-Hour	L529	NA	1	5/8"	24	57	DFR 8000

DRYWALL Grid Systems

Hanging and Framing

UL Fire Resistive Designs (continued)							
Deck Construction Type	UL Design Number	Concrete Thickness	# Drywall Layers	Minimum Drywall Thickness	Maximum Fixture Penetration (Ft ² /100 Ft ²)	Maximum Duct Penetration (In ² /100 Ft ²)	Drywall Grid System
DEITRICK TRADEREADY® FLOOR SYSTEM/CEILING DRYWALL ASSEMBLIES							
1-Hour	L564	3/4" Cement Fiber Units	1	5/8"	None	None	DFR 8000
1-Hour Corrugated Decking	G553	3/4"	1	5/8"	None	None	DFR 8000
ROOF/CEILING DRYWALL ASSEMBLIES							
Standing Seam Exposed Metal Roof With Batts/Blankets							
1-Hour	P516	NA	2	5/8"	None	None	DFR 8000
Mineral Fiber, Foam on Cellular, Fluted, Corrugated Metal Deck							
2-Hour	P501	NA	1	5/8"	None	None	DFR 8000
	P514	NA	1	5/8"	24	255	DFR 8000
1-1/2-Hour	P507	NA	1	5/8"	24	57	DFR 8000
	P510	NA	1	5/8"	24	57	DFR 8000
	P513**	NA	1	5/8"	24	144	DFR 8000
1-Hour	P508**	NA	1	5/8"	24	144	DFR 8000
	P509**	NA	1	5/8"	24	144	DFR 8000
	P510	NA	1	1/2"	24	57	DFR 8000
Mineral Fiber/Laminated Gypsum Planks							
1-1/2-Hour	P506	NA	1	5/8"	24	57	DFR 8000

* Depends on rating, manufacturer.

** Optional acoustical tile may be glue-applied to gypsum board.

*** Concrete thickness depends on joist depth used.

Armstrong Drywall "Design To Fit" Items XL7936G90 and XL8965 cannot be used as part of a UL Fire Resistive Design.

DFR 8000 – UL Designation, Fire Guard™ Drywall Grid System.

Fire Rated Expansion Joint

Fire expansion notch

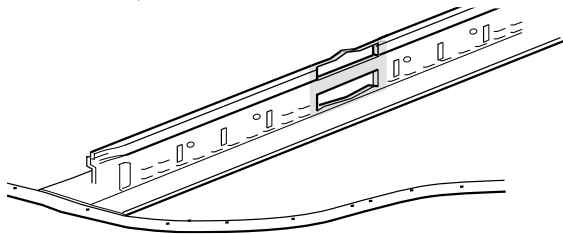

Collapsed fire expansion notch

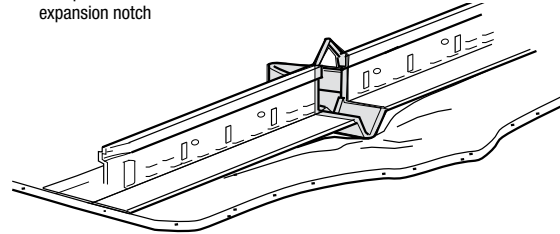

load data



Main Beam – Technical Load Test Data									
Item Number	Flange Width (in.)	Length (in.)	Web Height (in.)	Simple Span (Lbs./LF)					
				4'		3'		2'	
				L/240	L/360	L/240	L/360	L/240	L/360
HD8906	1-1/2"	144"	1-11/16"	28.14	18.66	57.3	43.19	143.0	95.5
HD8906 IIC	1-1/2"	144"	1-11/16"	28.14	18.66	57.3	43.19	143.0	95.5
HD8906 10	1-1/2"	120"	1-11/16"	28.14	18.66	57.3	43.19	143.0	95.5

Cross Tees – Technical Load Test Data													
Item Number	Flange Width (in.)	Length (in.)	Web Height (in.)	Simple Span (Lbs./LF)									
				72"		50"		4'		3'		2'	
				L/240	L/360	L/240	L/360	L/240	L/360	L/240	L/360	L/240	L/360
XL8965	1-1/2"	72"	1-1/2"	6.4	4.27								
XL8947P	1-1/2"	50"	1-1/2"			19.5	13.0						
XL8945P	1-1/2"	48"	1-1/2"					22.5	15.0				
XL8341	15/16"	48"	1-1/2"					24.8	16.59				
XL7341	15/16"	48"	1-11/16"					24.8	16.59				
XL7936 G90	1-1/2"	36"	1-1/2"							50.0	33.3		
XL8925	1-1/2"	26"	1-1/2"									117.0	98.0
XL8926	1-1/2"	24"	1-1/2"									158.0	129.0
XL7918	1-1/2"	14"	1-1/2"									107.0	71.5

NOTE: Allowable loads tested per ASTM C635 for deflection limited to L/360 and complies with ASTM C645 for deflection limited to L/240. See standards for additional information.

Membrane Load Values							
Component Combinations		Maximum Load in lbs./ft. ² at Hanger Wire/Cross Tee Spacing					
		48 / 24		48 / 16		36 / 16	
		L/240	L/360	L/240	L/360	L/240	L/360
Main	Cross Tee						
HD8906	– XL8965	3.20		4.66			
HD8906	– XL8947P	6.78	4.52	6.78	4.52	13.41	8.95
HD8906	– XL8945P	7.03	4.69	7.03	4.69	14.93	9.95
HD8901	– XL8945P	6.18	4.12	6.18	4.12	11.61	7.74
HD8906	– XL7936 G90					21.77	14.51
HD8901	– XL7936 G90					21.77	14.51
HD8906	– XL8926					26.13	21.77

Basic Products Used on Suspension Systems					
Material	Weight Lbs/SF	Maximum Main Beam Spacing	Maximum Cross Tee Spacing	Maximum Wire Spacing	Load on Wire
OSB 1/4"	0.9	48"	8" – 16"	48"	14.4 Lbs.
3/8"	1.3	48"	16"	48"	20.8 Lbs.
1/2"	1.7	48"	16"	48"	27.2 Lbs.
5/8"	2.2	48"	24"	48"	35.2 Lbs.
3/4"	2.5	48"	24"	48"	40.0 Lbs.
Plywood 1/4"	.075	48"	8" – 16"	48"	12.0 Lbs.
3/8"	1.1	48"	16"	48"	17.6 Lbs.
1/2"	1.5	48"	16"	48"	24.0 Lbs.
5/8"	1.8	48"	24"	48"	28.8 Lbs.
3/4"	2.2	48"	24"	48"	35.2 Lbs.
Gypsum Board 1/4"	1.2	48"	8" – 16"	48"	19.2 Lbs.
3/8"	1.4	48"	16"	48"	22.4 Lbs.
1/2"	2.0	48"	16"	48"	32.0 Lbs.
5/8"	2.4	48"	24"	48"	38.4 Lbs.
3/4"	4.2	48"	16"	48"	67.2 Lbs.
Cement Board 1/2"	3.0	48"	24"	48"	48.0 Lbs.
Cement Siding 5/8"	1.9	48"	16"	48"	30.4 Lbs.
Hard Board Siding 1/2"	2.0	48"	16"	48"	32.0 Lbs.
Water-Resistant Gypsum Board 5/8"	3.42	48"	16" or 24"	48"	57.7 Lbs.
Water-Resistant Gypsum Board 1/2"	2.8	48"	16"	48"	44.8 Lbs.
Expanded Steel Lath	3.4	48"	16"	48"	54.4 Lbs.
12 Gauge Sheet Steel	4.5	24"	16"	48"	72.0 Lbs.

NOTES: All framing on the exterior should be 16" O.C. or less.
 Some manufacturers make 1/2" gypsum board with special core to span 24" framing on interior ceiling installations (available on request).
 All steel product on exterior made from G90 galvanized finish.
 Data based on manufacturer's published data.
 * Use lower RPM (1,000-2,500) screw gun to install cement board screws with intermittent pressure.

Control Joints

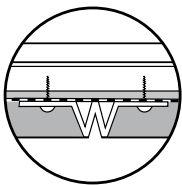

Please refer to ASTM C840, Section 20.3.3 to 20.4 for Control Joint Requirements.

Expansion Joints

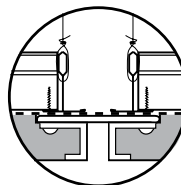

Ceiling expansion joints are installed to separate the metal suspension system when expansion joints occur in buildings or when metal changes direction. Expansion joints are required to separate a system in T-, H-, I-, and U-, or circle-shaped buildings to eliminate cracking from expansion.

Sound Control

sound control

The IBC uses two sound classes to measure sound isolation performance in building construction:
 Sound Transmission Class (STC) – sound transmitted through the air such as voices and music.
 Impact Insulation Class (IIC) – sound transmitted through the building structure such as foot traffic and objects dropped on the floor.
 A rating of 50 or above for both STC and IIC sound tests will satisfy the IBC's minimum requirements.

Understanding Sound Control Ratings	
STC/IIC Ratings	Description
55	Excellent
50	Loud speech barely audible
45	Some loud speech audible – not understood
30	Loud speech audible – well understood
25	Regular speech audible and understood through walls

Changes in STC/IIC Ratings	Description
+ / - 1	Almost perceptible
+ / - 3	Just perceptible
+ / - 5	Clearly Perceptible
+ / - 10	Twice (or half) as loud

Satisfy IBC requirements with a rating of 50 or above for STC and IIC sound tests – without two layers of drywall using Armstrong Drywall Grid.

Traditional Assembly – Field Tested Data				
	Traditional Assembly	Building Structure	STC	IIC
	1-1/2" Black Iron / 7/8" Channel 3-1/2" Batt Insulation 5/8" Gypsum	Bare Concrete Base 3" Concrete Slab Fluted Steel Decking 8" Bar Joist, 24" o.c.	55	48
Armstrong Standard Drywall Grid Assembly – Field Tested Data				
Item Number	Armstrong Assembly	Building Structure	STC	IIC
HD8906 XL8945	12' Main Beam / 4' Cross Tee 3-1/2" Batt Insulation 5/8" Gypsum	Bare Concrete Base 3" Concrete Slab Fluted Steel Decking 8" Bar Joist, 24" o.c.	55	47
Armstrong IIC Drywall Grid Assembly – Field Tested Data				
Item Number	Armstrong Assembly	Building Structure	STC	IIC
HD8906IIC XL8945 IIC Clip	12' Main Beam / 4' Cross Tee IIC Clip 3-1/2" Batt Insulation 5/8" Gypsum	6" Thick Slab Concrete Base with Vinyl Sheet Flooring	57	66

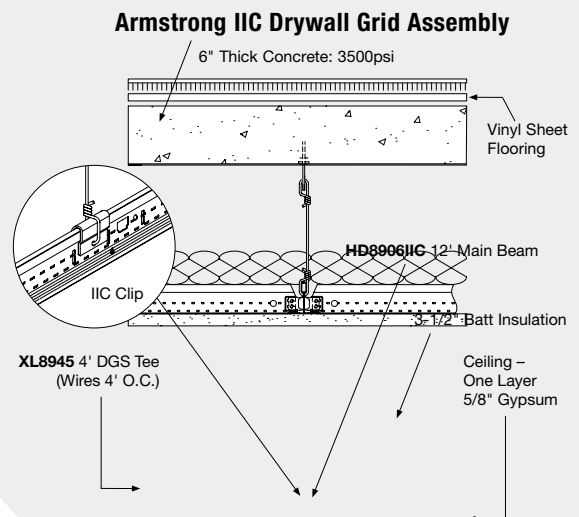

DRYWALL Grid Systems

Estimating Material

estimating



Item Number	Length	Pcs/Ctn	LF/Ctn	Lbs./Ctn	Area of ceiling completed by one carton (SF)						
					8" O.C.	16" O.C.	24" O.C.	36" O.C.	48" O.C.	50" O.C.	72" O.C.
DRYWALL GRID MAIN BEAM											
HD8906/HD8906G90/HD8906HC	144"	12	144	53			288	432	576	600	864
HD8906F08/HD8906F16	144"	12	144	53	Varies with radius						
HD890610	120"	12	120	49			288	432	576	600	864
DRYWALL GRID 1-1/2" FACE CROSS TEES											
XL8965	72"	36	216	78	144	288	432				
XL8947P/XL8947PG90**	50"	36	150	56	100	200	300				
XL8945P/XL8945PG90	48"	36	144	52	96	192	288				
XL7936G90	36"	36	108	39	72	144	216				
XL8925/XL8925G90**	26"	36	78	28							
XL8926/XL8926G90	24"	36	72	26	48						
XL7918**	14"	36	42	14							
DRYWALL GRID 15/16" FACE CROSS TEES											
XL7341/XL8341	48"	60	240	71		320	480				

** Dimensions are nominal.

Item Number	Length	Pcs/Ctn	LF/Ctn	Lbs/Ctn
REVERSE MOLDINGS				
7857	120"	30	360	51
7858	120"	20	240	67
DRYWALL UNHEMMED CHANNEL MOLDING				
7838	120"	20	200	36
DRYWALL ANGLE MOLDING				
HD7801G90	120"	30	300	38
KAM-12	144"	20	240	39
KAM-10	120"	20	200	33
LAM-12	144"	20	240	39

Estimating Lineal Feet of Grid Based on Square Footage of Ceiling	
On-center Spacing of Component	Percent of Square Footage
8"	108%
12"	100%
16"	76%
20"	60%
24"	50%
30"	40%
36"	33%
48"	25%
60"	20%

Example calculation based on 5,100 SF ceiling:

Main beam at 48" O.C.

$$5,100 \text{ SF} \times .25 = 1,275 \text{ LF}$$

$$1,275 \text{ LF} \div 144 \text{ LF/Ctn} = 9 \text{ cartons needed}$$

Cross tee at 16" O.C.

$$5,100 \text{ SF} \times .76 = 3,876 \text{ LF}$$

$$3,876 \text{ LF} \div 144 \text{ LF/Ctn} = 27 \text{ cartons needed}$$

Cross tee at 24" O.C.

$$5,100 \text{ SF} \times .50 = 2,550 \text{ LF}$$

$$2,550 \text{ LF} \div 144 \text{ LF/Ctn} = 18 \text{ cartons needed}$$

For additional information regarding Armstrong® Drywall Systems visit armstrongceiling.com/drywallgrid or reference:

BPCS-3539
Drywall Grid Systems
for Flat Applications

BPCS-3540
Drywall Grid Systems
for Curved Applications

BPCS-3541
Stucco/Plaster
Grid Systems

BPCS-3542
Synthetic Stucco
Grid Systems

CEILING Systems

1 877 276 7876

- Name of your Inner Circle Contractor or Gold Circle Distributor or Sales Representative
- Customer Service Representatives
7:30 a.m. to 5:00 p.m. EST, Monday through Friday
- **TechLine** – Technical information
8:00 a.m. to 5:30 p.m. EST, Monday through Friday
FAX 1-800-572-8324 or email:
techline@armstrongceiling.com
- Product Literature and Samples
Express service or regular delivery
- Request a personal copy of the
Armstrong Ceiling Systems catalog

armstrongceiling.com/drywallgrid

- Latest product and program news
- Real-time selection and technical information
- Contacts – reps, where to buy, how to install
- Submittal pages
- Literature and samples information
- CAD renderings

These drawings show typical conditions in which the Armstrong product depicted is installed. They are not a substitute for an architect's or engineer's plan and do not reflect the unique requirements of local building codes, laws, statutes, ordinances, rules and regulations (legal requirements) that may be applicable for a particular installation.

Armstrong does not warrant and assumes no liability for the accuracy or completeness of the drawings for a particular installation or their fitness for a particular purpose. The user is advised to consult with a duly licensed architect or engineer in the particular locale of the installation to assure compliance with all legal requirements.

Armstrong is not licensed to provide professional architecture or engineering design services.

Engineering data included was provided by an outside engineering company.