

DRYWALL GRID SYSTEMS

HANGING & FRAMING
FLAT CEILINGS

Inspiring Great Spaces®

Armstrong®
CEILING SOLUTIONS

WORK SMARTER

Eliminate the labor-intensive cutting, tying, and spacing of track and channel framing. Our systems are engineered with rout locations and cross tees to maintain precise module spacing. Main beams have 51 rout locations and cross tee lengths of 50", 26", and 14" to accommodate type F fixtures without field modifications or accessories. Pre-notched main beams simplify curved drywall installations.

Our Drywall Systems are manufactured to meet or exceed ASTM standards and code requirements, and are engineered to provide economical alternatives to stud and track construction.

The vertical load carrying capacity for main beam and cross tee members is determined in accordance with ASTM test method E3090. Suspended ceiling systems constructed of screw-attached gypsum board panels may be installed in accordance with ASTM C1858 and are exempt from code prescribed requirements of acoustical or lay-in panel ceilings. This standard practice is limited to framing that supports a single level ceiling and is surrounded by and attached to laterally braced walls or soffits.

DRYWALL Grid Systems

Code Compliance You Can Trust

Meets:

- ASTM C1858
- ASTM C635
- ASTM C645
- ASTM C754
- ASTM C840
- ASTM E3090
- ICC Evaluation Service Report ESR-1289
- City of LA – RR 25348
- IBC categories D, E, and F single layer drywall ceilings are exempt from lateral force bracing requirements, regardless of room size
- Miami-Dade County, Florida wind uplift – NOA No. 15-0127.04–03/17/2020
- Miami-Dade County, Florida impact testing – NOA No. 14-1204.05–10/07/2019
- Consult local codes for specific requirements
- Locking Angle Mechanism creates repeatable accurate spacing for corrections to molding

Performance

- **PeakForm**® patented profile increases strength and stability for improved performance during installation
- **SuperLock**™ main beam clip is engineered for a strong secure connection and fast accurate alignment confirmed with an audible click; easy to remove and relocate
- **ScrewStop**™ reverse hem prevents screw spinoff on 1-1/2" wide face



Flat Drywall Grid Installation

DRYWALL GRID SYSTEMS

TABLE OF CONTENTS

- 2 Code Compliance
- 2-3 Performance
- 4 Components
- 5 Moldings
- 6 Corrosion Prevention
- 7-8 Axiom® Trim
- 9-10 Axiom Building Perimeter System
- 11-12 Rout Locations
- 12-13 Accessories
 - 14 System Framing
 - 15 Type F Fixtures
- 16-19 Suspended Drywall Grid System
 - 20 Hanging and Framing
 - 21 Yoke Wire Hung Ceilings
 - 22 Trapeze Supported Loads
 - 23 Double Hung Ceilings
 - 24 Triple Hung Ceilings
 - 25 Exterior Wind Load Data
- 26-27 UL® Fire Resistant
 - 28 Load Data
 - 29 Basic Products
 - 30 Sound Control
 - 31 Estimating

- **Rotary-stitched** – Greater torsional strength and stability
- **1-1/2" wide face** main beams and cross tees – Easy installation of screw-applied gypsum wallboard
- **G40, G90 hot dipped galvanized coating** – Corrosion resistance
- **G90 hot dipped galvanized coating** – Superior corrosion resistance for exterior applications
- **Heavy-duty load rating** – Minimum 16 Lbs/LF on main beams
- **Fire rated** – Applicable to 25 UL® Fire Resistant designs (D501, D502, G523, G524, G527, G528, G529, G553, J502, L502, L508, L513, L515, L525, L526, L529, L564, P501, P506, P507, P508, P509, P510, P513, P514, P516). Item XL7936G90 and XL8965 are not fire rated.

Wind uplift and impact testing construction available, including Miami Dade/Broward County, Florida

- **Cross tee spacing:**
 - 24" O.C. for 5/8" drywall
 - 16" O.C. for 1/2" drywall

COMPONENTS

MAIN BEAMS

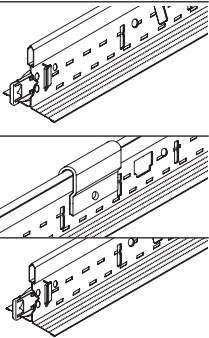
Item Number	Length	Face Dimension	Profile Height	Duty Load	Fire Rated	Routs	Load Test Data (Lbs/LF)						Perspective
							L/240 Simple Span			L/360 Simple Span			
							2'	3'	4'	2'	3'	4'	
HD8906 HD8906G90 HD8906HRC	144"	1-1/2"	1-11/16"	Heavy Duty	Yes	51 routs – starting 2-1/4" from each end†	143.00	57.30	28.14	95.5	43.19	18.66	
HD8906HC	144"	1-1/2"	1-11/16"	Heavy Duty	Yes	51 routs – starting 2-1/4" from each end†	143.00	57.30	28.14	95.5	43.19	18.66	
HD890610	120"	1-1/2"	1-11/16"	Heavy Duty	Yes	51 routs – starting 2-1/4" from each end†	143.00	57.30	28.14	95.5	43.19	18.66	
Metric							Hanger Spacing (KG/LM)						
Item Number	Length	Face Dimension	Profile Height	Duty Load	Fire Rated	Routs	600mm	900mm	1200mm	600mm	900mm	1200mm	
HD7940	3600mm	30mm	38mm		Yes	200mm O.C.	150.0	68.3	29.34	100.0	45.35	19.56	
7940G	3600mm	30mm	38mm		Yes	150mm O.C. – starting 75mm from each end†	114.0	51.92	22.40	76.39	34.61	14.93	

† Type F fixture compatible

CROSS TEES

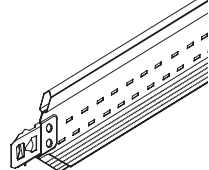
Item Number	Length	Face Dimension	Profile Height	Fire Rated	Routs	Load Test Data (Lbs/LF)						Perspective
						L/240 Simple Span			L/360 Simple Span			
						2'	3'	4'	2'	3'	4'	
XL8965 XL8965HRC	72"	1-1/2"	1-1/2"	Yes	6 routs – starting 24" from each end†	72"			72"			
						6.87			4.58			
						50"			50"			
XL8947P XL8947PG90	50"	1-1/2"	1-1/2"	Yes	8 routs – starting 10" from each end†	19.5			12.79			
						2'	3'	4'	2'	3'	4'	
XL8945P XL8945PG90 XL8945HRC	48"	1-1/2"	1-1/2"	Yes	9 routs – center rout and starting 10" from each end†			22.5			14.27	
XL7936G90	36"	1-1/2"	1-1/2"	No	none		50.00			31.33		
XL8926 XL8926G90	24"	1-1/2"	1-1/2"	Yes	3 routs – center rout and 10" from each end†	158.0				90.25		
Metric						Load Total Data (KG/LM)						
Item Number	Length	Face Dimension	Profile Height	Fire Rated	Routs	L/240	L/360	L/240	L/360			
XL7961	1600mm	30mm	38mm	Yes	800mm center of tee	10.25 @ 6'	6.84 @ 6'	15.15 @ 1600mm	10.18 @ 1600mm			
XL7930	38mm	30mm	38mm	Yes	450mm, 600mm, 750mm	22.4 @ 4'	14.93 @ 4'	33.33 @ 1200mm	22.22 @ 1200mm			
XL7925	38mm	30mm	38mm	No	none	51.92 @ 3'	34.61 @ 3'	77.26 @ 900mm	51.51 @ 900mm			

NOTE: All items available in High Recycled Content (HRC) as special order.

† Type F fixture compatible

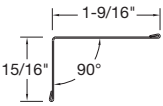
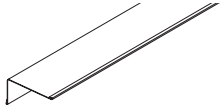
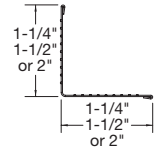
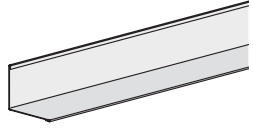
Item Number	Length	Description	Profile	Perspective
7858	144"	Reverse Angle Molding nominal 1-9/16" x 15/16"		
KAM10	120"	Knurled Angle Molding nominal 1-1/4" x 1-1/4" - 25g		
KAM12 KAM12G90 KAM12HRC	144"	Knurled Angle Molding nominal 1-1/4" x 1-1/4" - 25g		
KAM1510 KAM1512 KAM151020 KAM151020G90 KAM151020EQ	120" 144"	Knurled Angle Molding nominal 1-1/2" x 1-1/2" (KAM1510 & KAM1512 - 25g; KAM151020 - 20g; KAM151020G90 - 20g; KAM151020EQ - 22g)		
KAM21020 KAM21025 KAM21020EQ	120" 144"	Knurled Angle Molding nominal 2" x 2" (20g) (KAM21020 - 20g; KAM21025 - 25g; KAM21020EQ 22g)		
LAM12 LAM12G90 LAM12HRC	144"	Locking Angle Molding nominal 1-1/4" x 1-1/4"		









NOTE: All items available in High Recycled Content (HRC) as special order.

CORROSION PREVENTION

DRYWALL TRANSITION MOLDING

Corrosion prevention is an essential factor in the economical utilization of galvanized sheet metal for ceiling suspension systems. Armstrong Ceilings provides G40 for standard construction per ASTM C645. When conditions include exposure to extreme moisture and salt water, G90 is available per ASTM A653.



Material: Commercial-quality cold rolled hot dipped galvanized steel

Item Number	Length/Item Description	Face Dimension	Flange	Profile Height	
7901	120" Shadow Reveal Molding	3/8" shadow reveal	9/16"	1-1/4"	
7902	120" Shadow Reveal Molding	3/8" shadow reveal	15/16"	1-1/4"	
7903	120" Inverted T Molding	1" inverted T	–	1-1/2"	
7904 7904PF*	120" Flush Transition Molding	15/16" horizontal	15/16"	1-1/4"	
7905 7905PF*	120" Flush Transition Molding	9/16" horizontal	9/16"	1-1/4"	
7906	120" F Molding	120" vertical transition	–	1-7/16"	
7907	120" Tegular Transition Molding	9/16" horizontal	9/16"	1-1/4"	
7908	120" Tegular Transition Molding	15/16" horizontal	15/16"	1-1/4"	

* 7904PF and 7905PF feature protective film on the acoustical wall angle flange for faster, easier finishing.

AXIOM DRYWALL TRANSITIONS

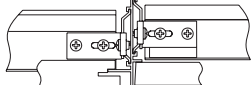
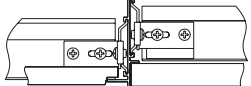
Material: Extruded aluminum, alloy 6063

Item Number	Length/Item Description	Dimensions	
AXTRVESTR	Straight Transition for Vector® Ceiling	120 x 2-9/16 x 1-11/16"	 <p>Axiom® – Transitions with Vector® panel to drywall perimeter (AXTRVESTR)</p>
AXTRTECUR	Curved Transition for Tegular	120 x 2-9/16 x 1-11/16"	 <p>Axiom® – Transitions with Tegular panel to drywall perimeter (AXTRTESTR, AXTRTECUR)</p>
AXTR2STR	2" Straight Transition	120 x 2 x 1-1/2"	 <p>Acoustical-to-Drywall Drywall-to-Drywall</p>
AXTR2CUR	2" Curved Transition	120 x 2 x 1-1/2"	
AXTR4STR	4" Straight Transition	120 x 4 x 1-1/2"	
AXTR4CUR	4" Curved Transition	120 x 4 x 1-1/2"	
AXTR6STR	6" Straight Transition	120 x 6 x 1-1/2"	
AXTR6CUR	6" Curved Transition	120 x 6 x 1-1/2"	
AXTR8STR	8" Straight Transition	120 x 8 x 1-1/2"	
AXBTSTR	Drywall Bottom Trim	120 x 1-1/8 x 27/32"	

ACCESSORIES

AX4SPICEB	Splice Plate	–	
AXTBC	T-Bar Connector Clip	–	

AXIOM® TRIM

AXIOM ONE-PIECE DRYWALL TRIM

*For use with 5/8" drywall only

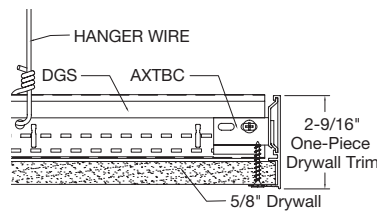
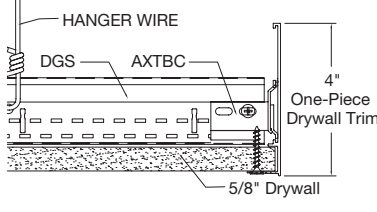
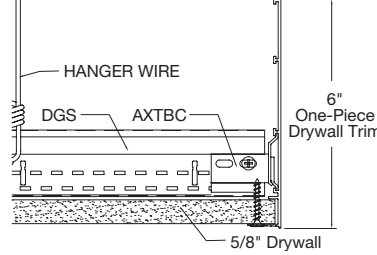

Material: Commercial-quality extruded aluminum alloy 6063

Item Number	Length/Item Description	
AX1PC2STR	2.5" One-Piece Straight Drywall Trim	
AX1PC2CUR	2.5" One-Piece Curved Drywall Trim	
AX1PC4STR	4" One-Piece Straight Drywall Trim	
AX1PC4CUR	4" One-Piece Curved Drywall Trim	
AX1PC6STR	6" One-Piece Straight Drywall Trim	
AX1PC6CUR	6" One-Piece Curved Drywall Trim	

AXIOM POCKET WITH FACE PLATE TO DRYWALL TRANSITION

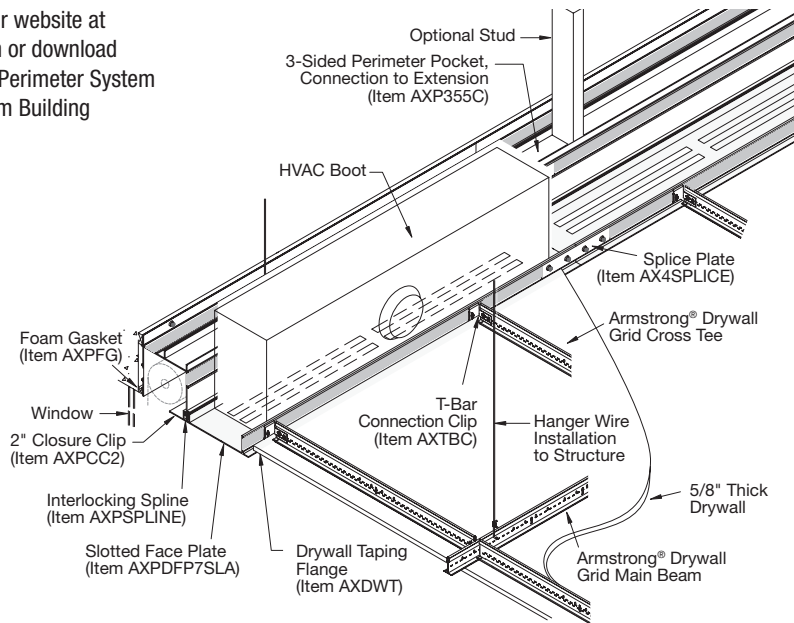
For more information, visit our website at armstrongceilings.com/axiom or download BPCS-3911 Axiom® Building Perimeter System Brochure or BPCS-3923 Axiom Building Perimeter Data Page.

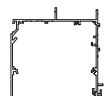
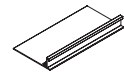

Item Number	Length/ItemDescription	
AXP355LC	3-Sided Lutron Compatible Shade Pocket with Connection to Extension/Face Plate Piece	
AXPC2	2" Shade Closure Clip	
AXPC3	3" Shade Closure Clip	
AXPDFP4DTSLA	4" Axiom Perimeter Face Plate with Drywall Flange – 2 Slot Pattern	
AXPDFP4DTSLB	4" Axiom Perimeter Face Plate with Drywall Flange – 1 Slot Pattern	
AXPDFP7DT	7" Axiom Perimeter Face Plate with Drywall Flange – Unslotted	
AXPDFP7DTSLA	7" Axiom Perimeter Face Plate with Drywall Flange – 2 Slot Pattern	
AXPDFP7DTSLB	7" Axiom Perimeter Face Plate with Drywall Flange – 1 Slot Pattern	

ROUT LOCATIONS

ROUT LOCATIONS

Imperial

HD8906 (HRC)/HD890610*

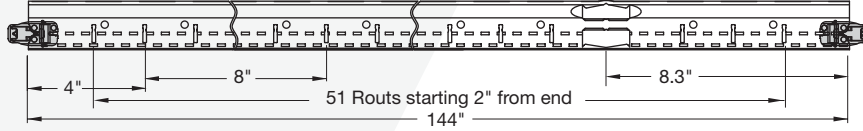

* HD890610 is 120" in length

HD8906IIC

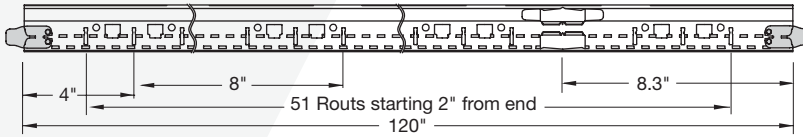

XL8965 (HRC) (Type F Compatible)

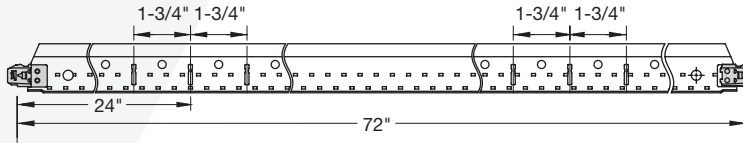

XL8947P (Type F Compatible)

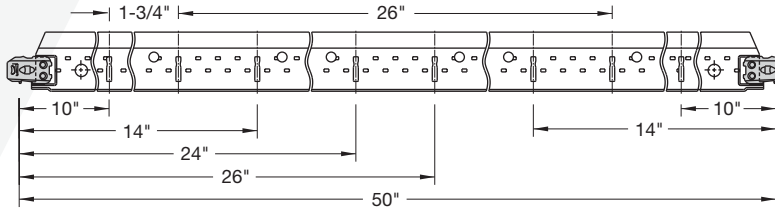

XL8945HRC/XL8945P (Type F Compatible)

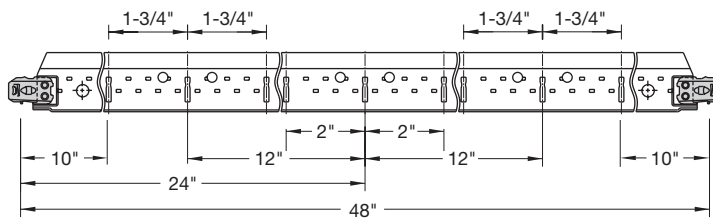

Imperial

XL7936G90

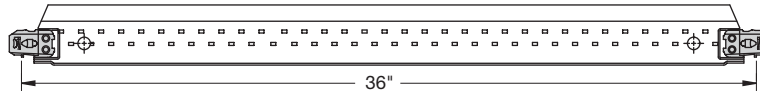

XL8926

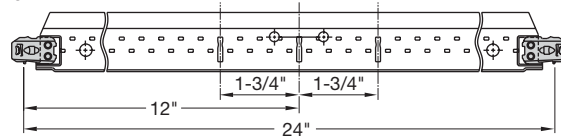

Metric

HD7940

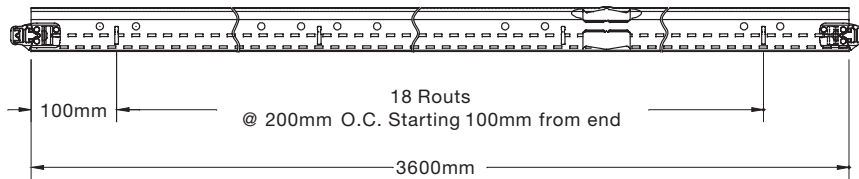

7940G

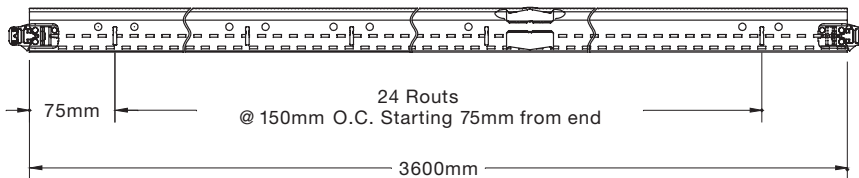

XL7961

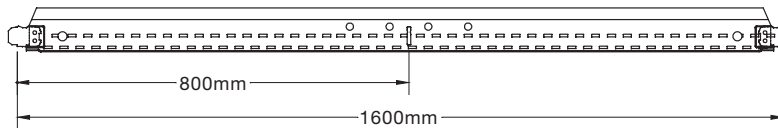

XL7930

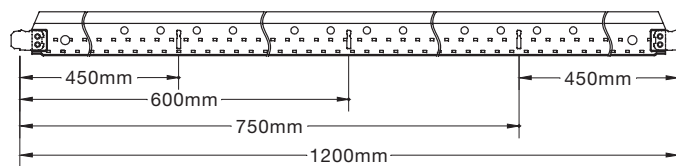

XL7925

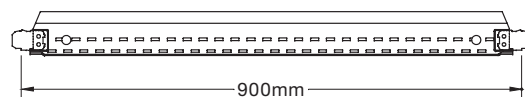

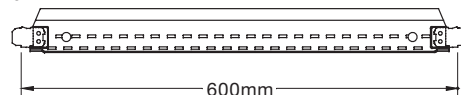

XL7920



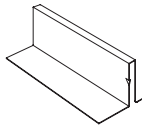
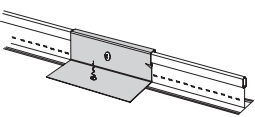
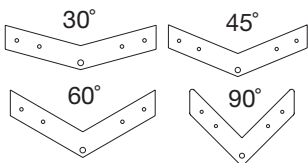
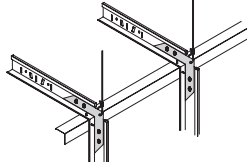
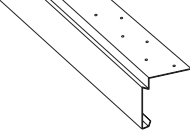
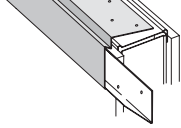
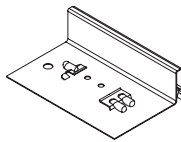
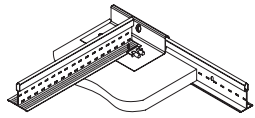
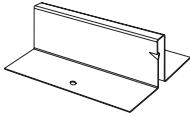
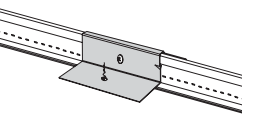
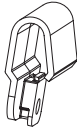
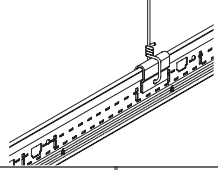
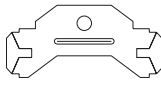
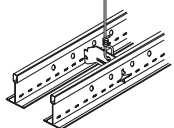

ACCESSORIES

DRYWALL GRID ACCESSORIES

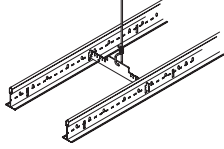
A variety of drywall grid accessories are available to provide problem-solving solutions that save time, labor, and money. For a complete list of accessories, request submittal BPCS-3082.

Item Number	Quantity	Description	Perspective	Application
DWACS	100	Drywall Attachment Clip facilitates transition from drywall to acoustical ceiling; locks under bulb of grid section to prevent upward movement and provide secure attachment surface on one side of exposed grid.		
DW30C DW45C DW60C DW90C	250 250 250 250	30-, 45-, 60-, and 90-degree Drywall Angle Clips are used to create positive and secure angles for drywall and ceiling installations on either main beams or cross tees.		
TT10	30	Partition Top Trim is used to finish the top of a drywall partition for a continuous drywall/acoustical ceiling interface.		
DW58LT	125	DW58LT – Transition Clip for 5/8" Drywall with Locking Tabs ; facilitates transition from drywall to acoustical ceiling; one-sided hold down clip; eliminates need for drywall bead. Locking tabs provide secure location for Drywall Grid System tees.		
DW50LT	125	DW50LT – Transition Clip for 1/2" Drywall with Locking Tabs ; facilitates transition from drywall to acoustical ceiling; one-sided hold down clip; eliminates the need for a drywall bead. Locking tabs provide secure location for Drywall Grid System tees.		
IIC	36	Impact Isolation Clip for use with HD8906IIC drywall grid main beam. Provides up to 8 points of IIC improvement to ensure your project meets IBC requirements.		
MBSC2	200	Main Beam Spacer Clip (2" in length) is used to space two parallel main beams 2" O.C. for air supply or return.		
GSC9 GSC12 GSC16	100 100 100	Adjustable Grid Spacer Clip is used to space two parallel main beams for light fixtures, air diffusers, etc.; allows for 1/4" adjustments with three different clips.		

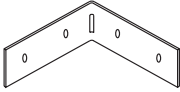
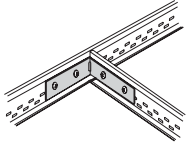
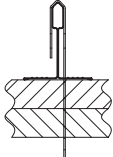
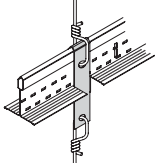
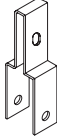
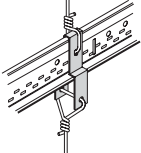
DRYWALL GRID ACCESSORIES (continued)

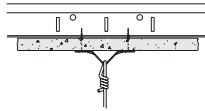
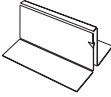
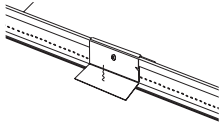
Item Number	Quantity	Description	Perspective	Application
XTAC	100	Cross Tee Adapter Clip is used to attach field-cut cross tees to main beams.		
DDC	250	Double Drywall Clip is used to hang suspension system below existing 1-1/2" grid face, transferring weight directly to hanger wire; may be used to preserve the fire rating of an existing ceiling and to support heavy accessories; allows for double layer of 5/8" gypsum board.		
DLCC	250	Direct Load Ceiling Clip is used to hang suspension system below existing 15/16" grid face, transferring weight directly to hanger wire; may be used to preserve the fire rating of an existing ceiling and to support heavy accessories.		
DWC	250	Drywall Clip allows for a second ceiling to be installed below a drywall ceiling; attach through installed drywall to supporting structure.		
MBAC	70	Main Beam Adapter Clip attaches to web of suspension system section; provides larger surface for screw attachments; used as a hold down clip for thin material (metal or plastic lay-in panels); fastens drywall track to underside of exposed suspension system with lay-in panels, leaving suspension system face free of screw holes.		

SYSTEM FRAMING

HANGING & FRAMING

The grid system is comprised of main beams and cross tees that are suspended by hanger wires to the structural deck. Sections of main beams lock together end-to-end while cross tees span between the main beams. The ends of the main beams and cross tees rest on the wall channel or angle molding that run around the perimeter of the space.

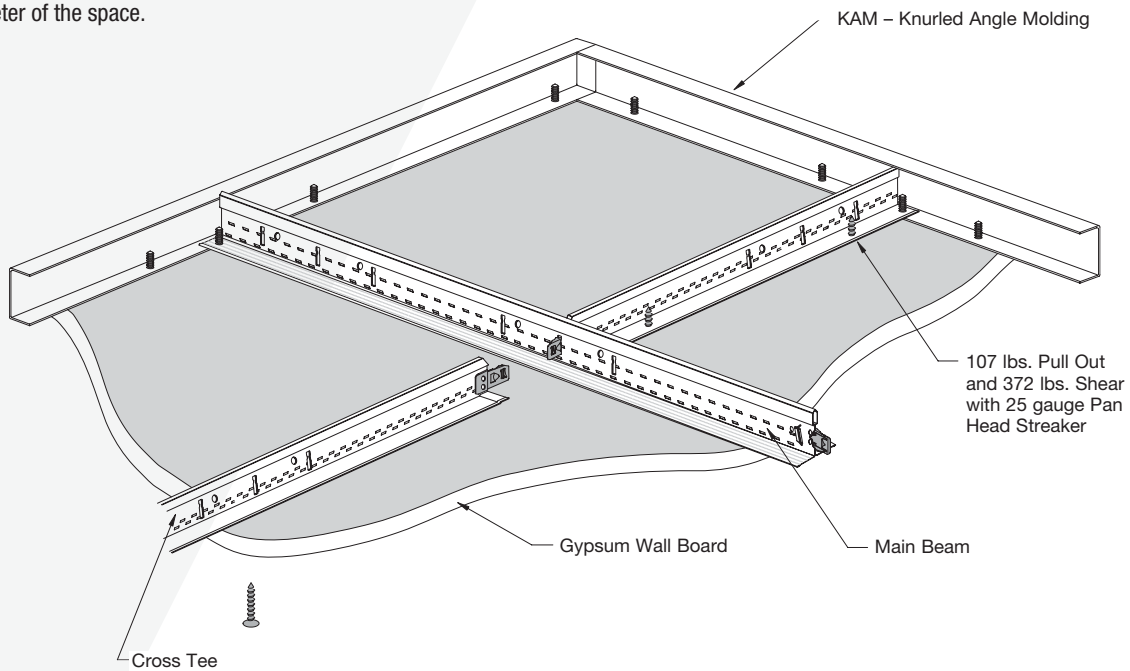

SQUARING UP THE SYSTEM

Once you've hung your first two main beams and border cross tees, install two full cross tees between the main beams and in line with the first two border cross tees. To square up the system, simply measure across the diagonals of the opening. The measurements will be the same if the grid is square. If the grid is not square, shorten one of the main beams until the diagonals are equal.

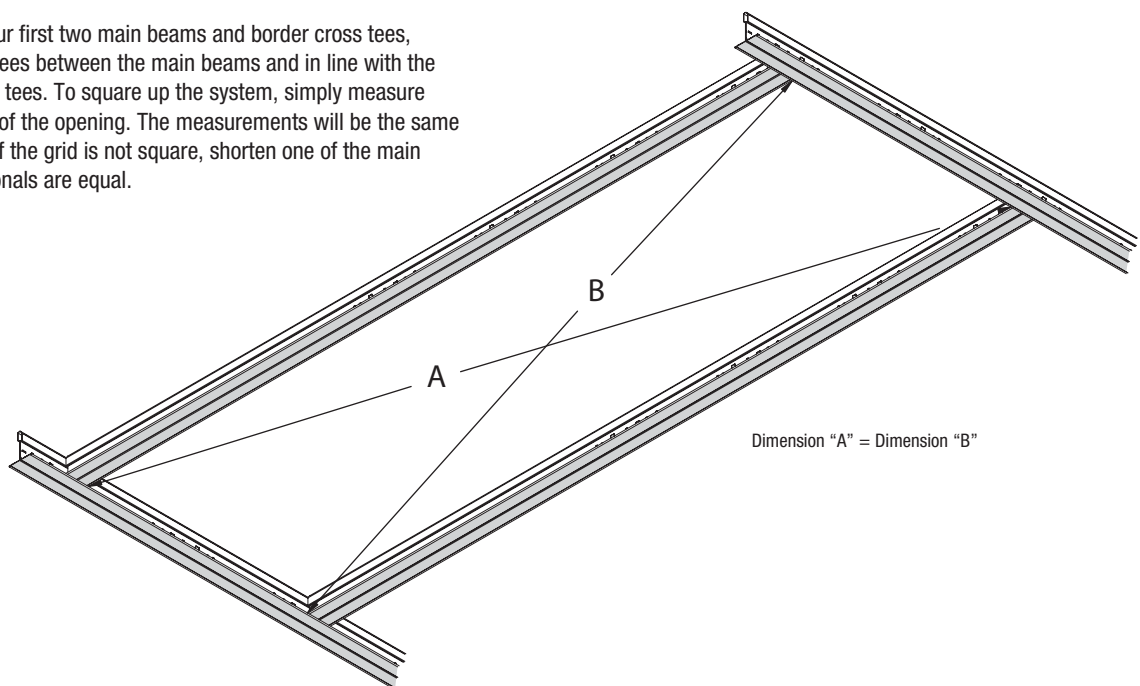

Type F fixtures, access panels, and air diffusers require a full 12", 24", or 48" opening dimension. The Armstrong® Drywall Grid System main beams and cross tees have additional routs in the web to accommodate this larger opening for type F fixtures. Using our 14", 26", 50", and 72" cross tees, type F fixtures fit perfectly without field cutting or special accessories.

When installing type F fixtures **parallel** to the main beams, use a 72" and 48" cross tee for easy placement of fixtures without field modifications.

When installing fixtures **perpendicular** to the main beams, use our 72" cross tees for virtually limitless fixture placement.

Main Beams

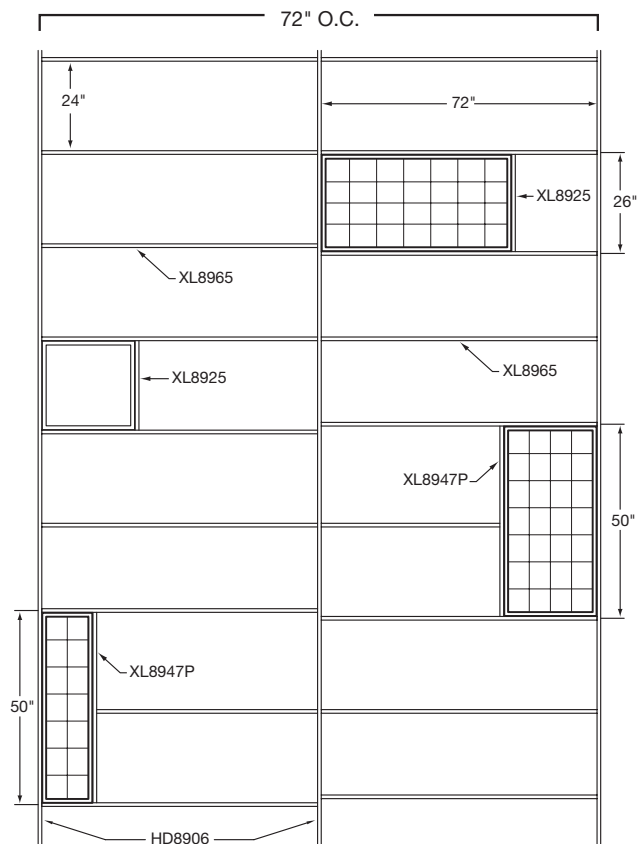
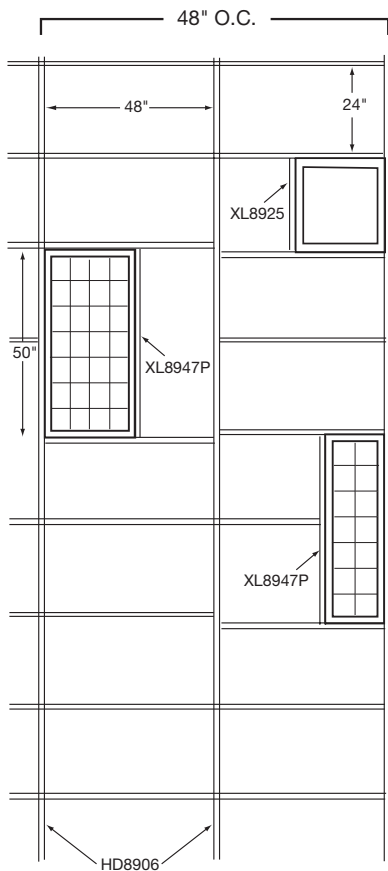

Item No.	Description	Fixture Length
Drywall Linear Lighting		
DGSLTK24	2' Linear Light Trim Kit	24" x 4"
DGSLTK30	2' - 6" Linear Light Trim Kit	30" x 4"
DGSLTK48	4' Linear Light Trim Kit	48" x 4"
DGSLTK60	5' Linear Light Trim Kit	60" x 4"
DGSLTK72	6' Linear Light Trim Kit	72" x 4"
DGSLTK90	7' - 6" Linear Light Trim Kit	90" x 4"
DGSLTK96	8' Linear Light Trim Kit	96" x 4"
DGSLTK120	10' Linear Light Trim Kit	120" x 4"
DGSLTKCON	10' Continuous Linear Light Trim Kit	10'

Linear Light Trim Kits designed to work with 5/8" drywall

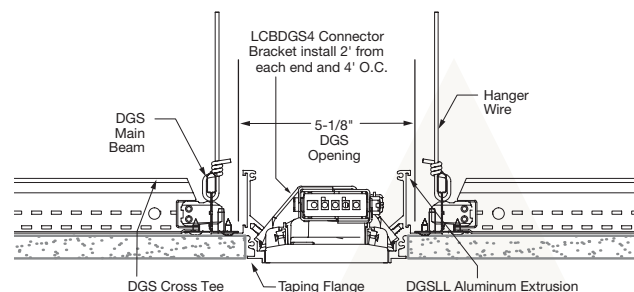

SUSPENDED DRYWALL GRID SYSTEMS

SUSPENDED DRYWALL GRID SYSTEM DETAILS

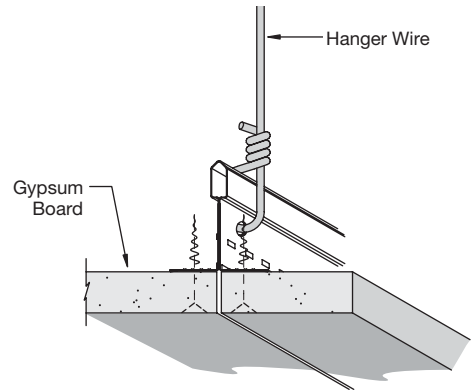
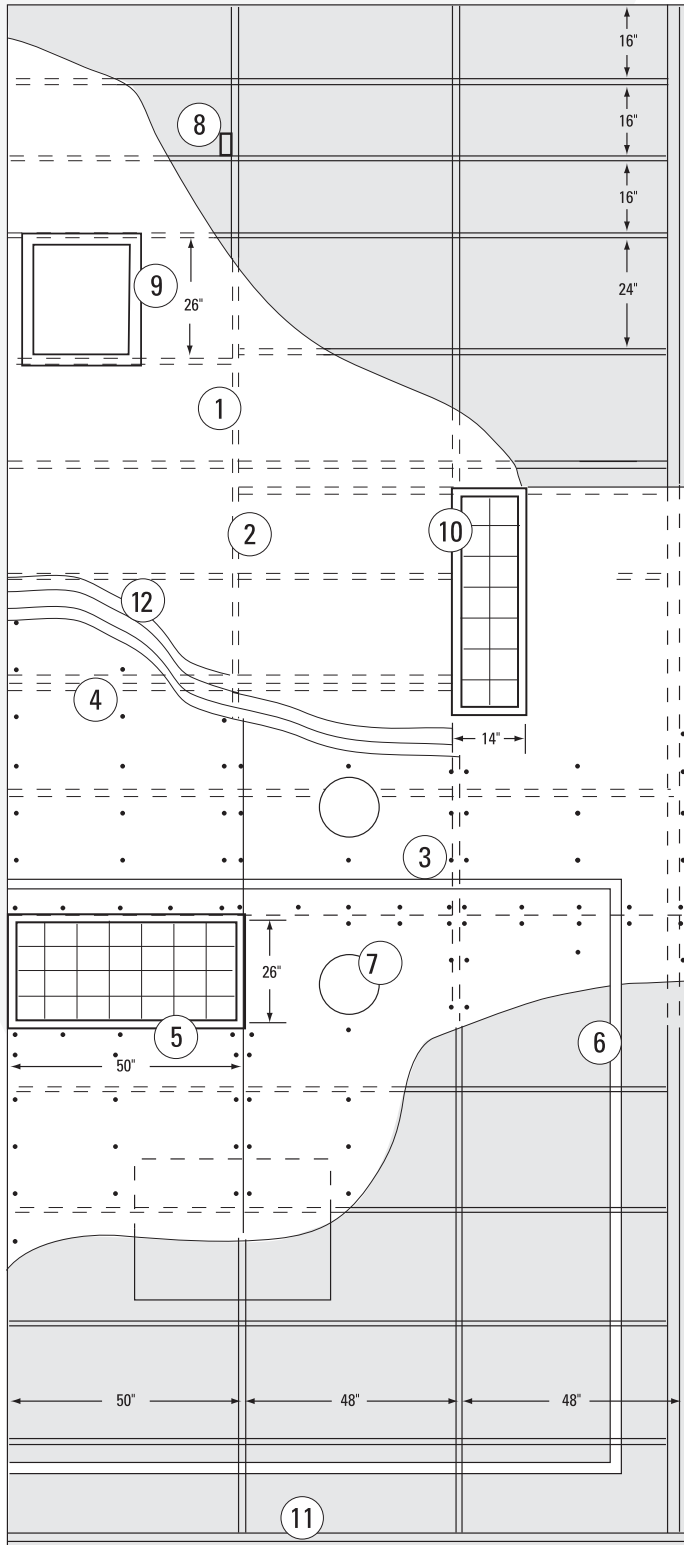

1 Butt Joint

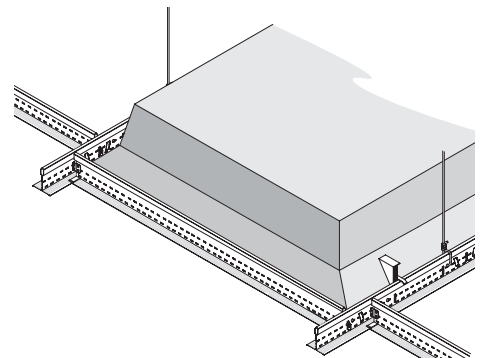

5 Type F Fixture

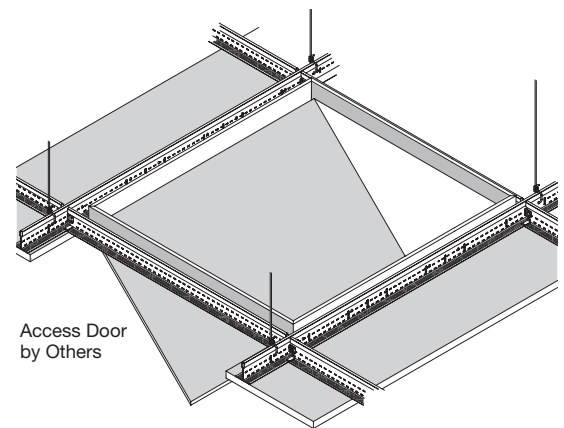

9 Access Door

SUSPENDED DRYWALL GRID SYSTEMS

SUSPENDED DRYWALL GRID SYSTEM DETAILS

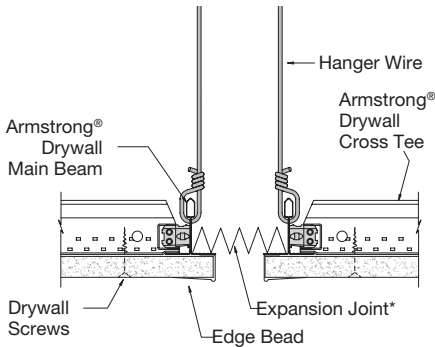

2 Expansion Joint*

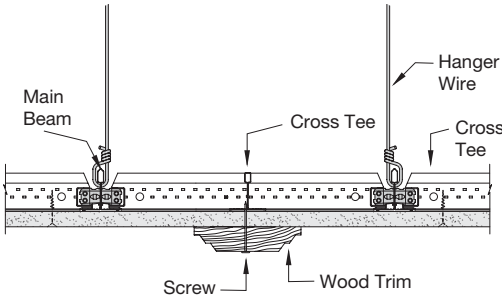

3 Wood Trim

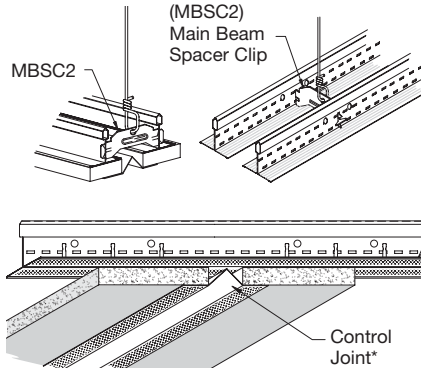

4 Control Joint

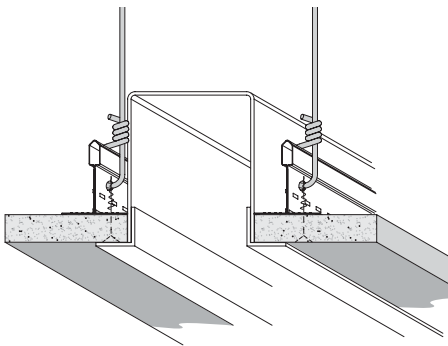

6 Air Bar

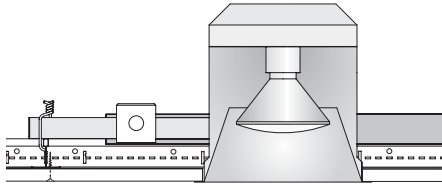

7 High Hat Fixture

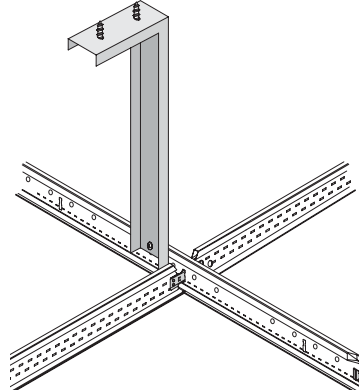

8 Vertical Brace

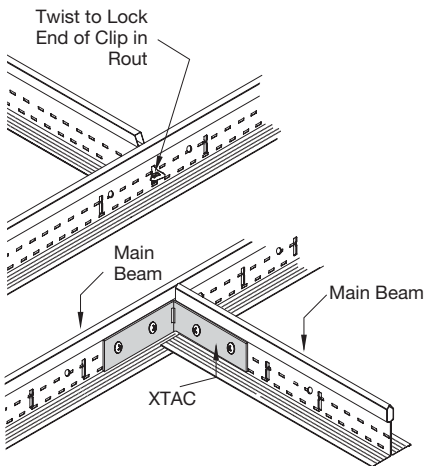

10 Securing a Single Cross Tee

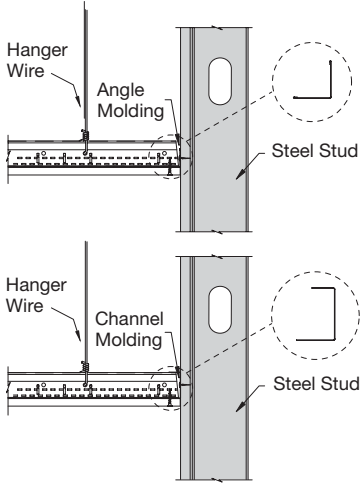

11 Channel and Angle Molding

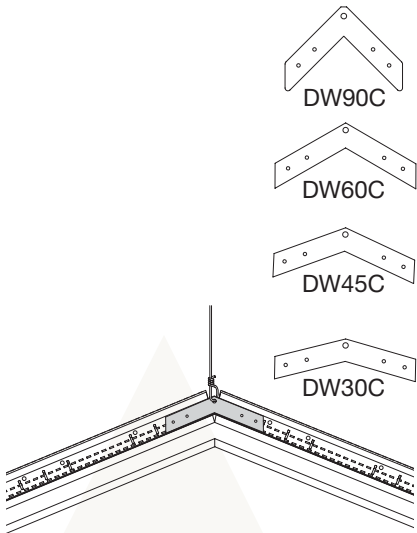

12 Angle Clip

SUSPENDED DRYWALL GRID SYSTEMS

SUSPENDED DRYWALL GRID SYSTEM DETAILS

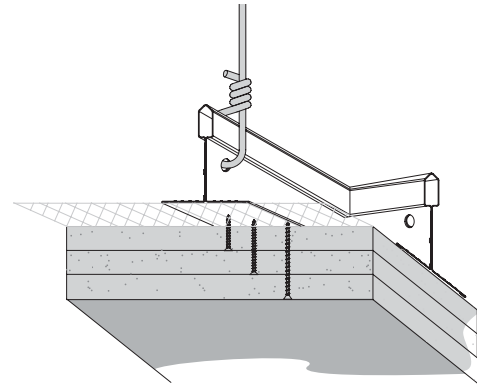
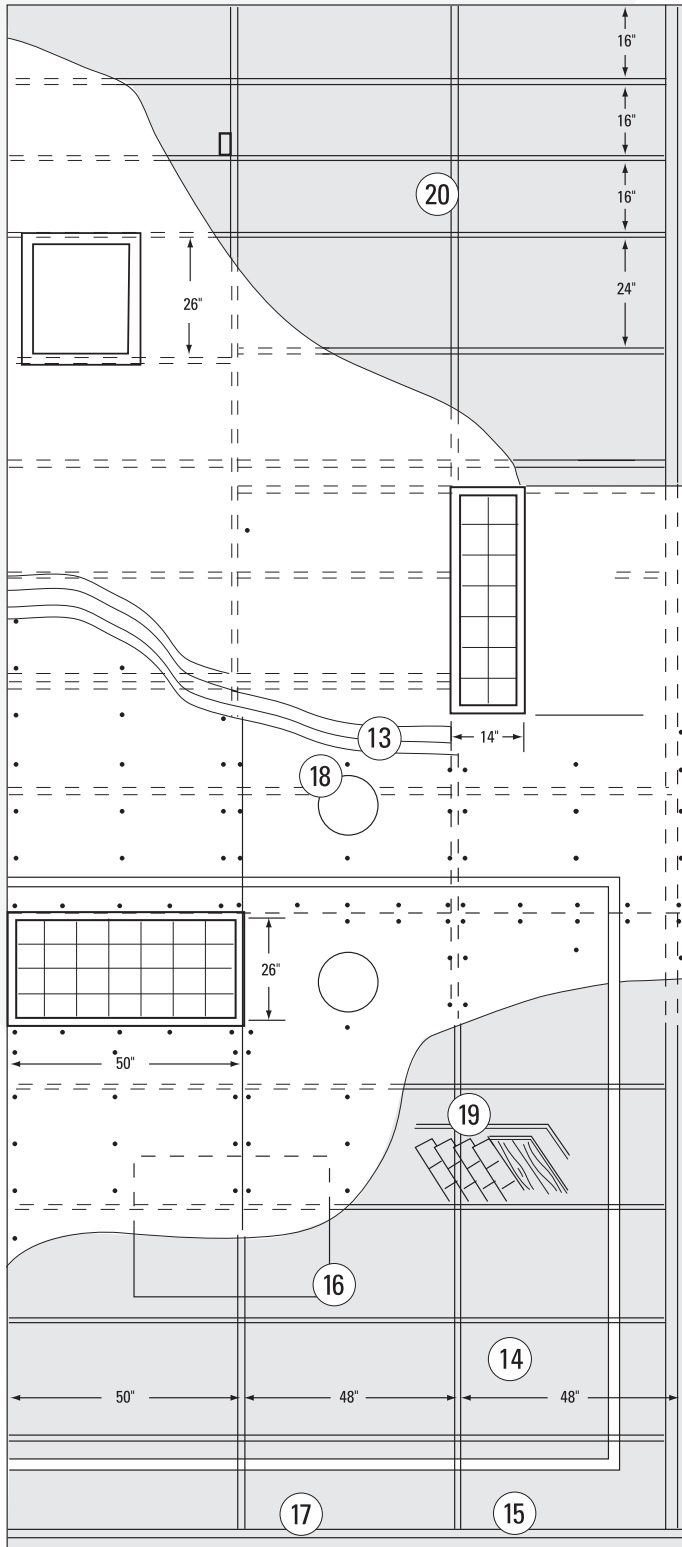

13 Triple Layer with Security Lath

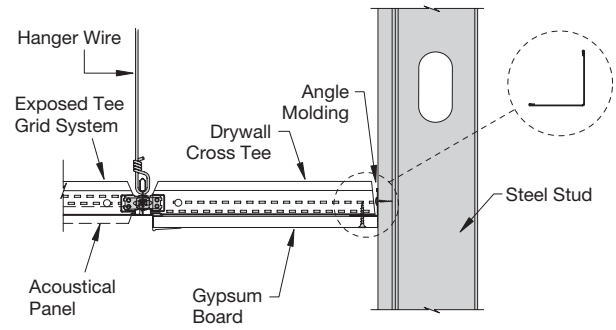

16 Transition

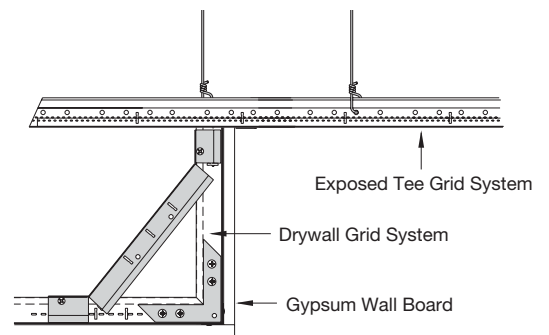

NOTE: Brace as required by code

19 Drywall Vertical

SUSPENDED DRYWALL GRID SYSTEM DETAILS

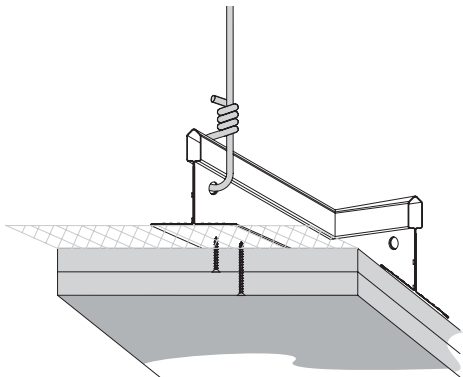

14 Double Layer with Security Lath

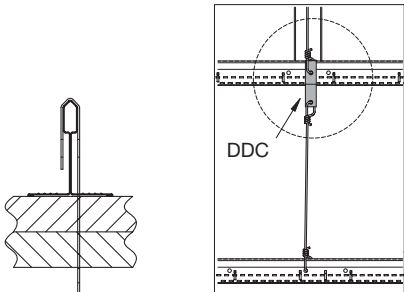

15 Double Hung Ceiling

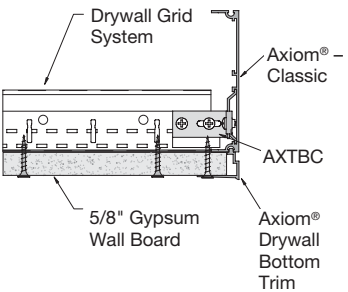

17 Axiom® Perimeter Trim

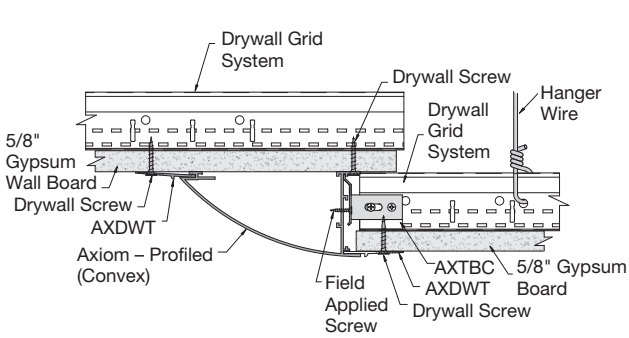

18 Alternate Finishes

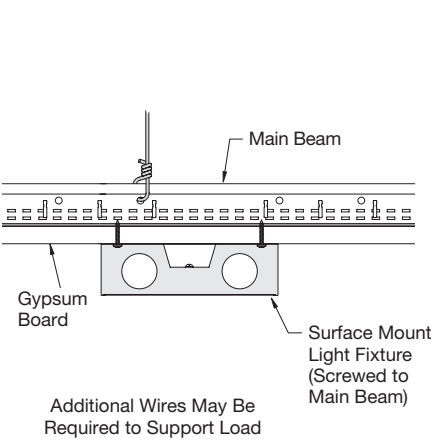

20 Surface Mount Fixture

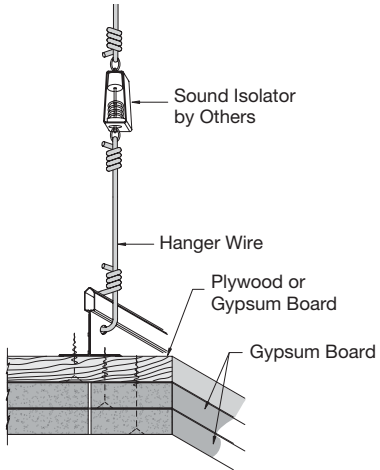

21 Triple Layer with Sound Isolators

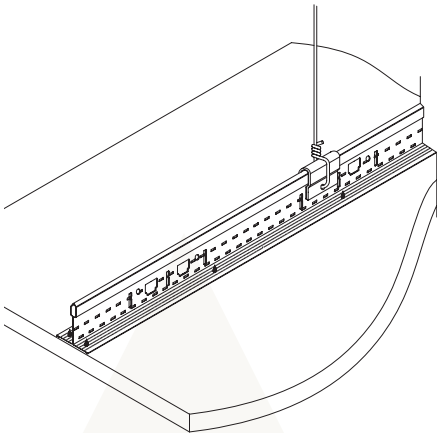

22 HD8906 with IIC Clip

WIRE LOADING

HANGING & FRAMING

9 Gauge Wire Breaking Strength and Technical Data

9 Gauge Wire
Diameter .148"
Galvanized Steel

**645 lbs.
Maximum Safe
Wire Load**

3 Turns in 3"
Per ASTM C636

**450 lbs. Pullout –
Hanger Wire Hole**

12 Gauge Wire Breaking Strength and Technical Data

12 Gauge Wire
Diameter .105"
Galvanized Steel

**275 lbs.
Maximum Safe
Wire Load**

3 Turns in 3"
Per ASTM C636

**500 lbs. Pullout –
Hanger Wire Hole**

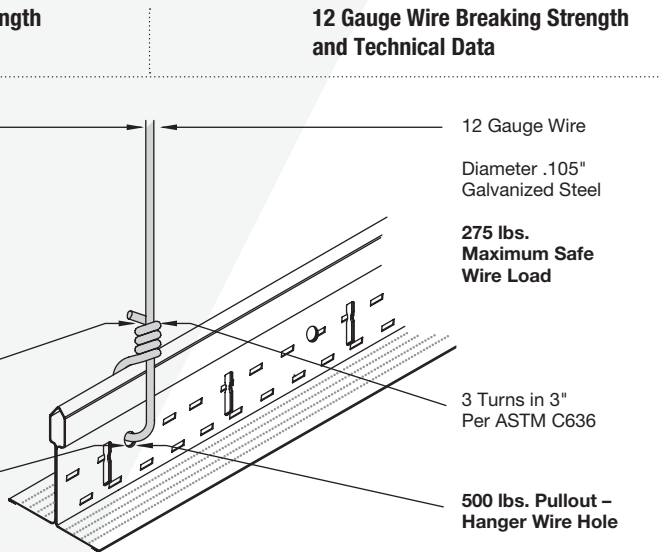

COUNTER SPLAYED WIRES

Objects in the plenum may obstruct placement of vertical hanger wires and require splayed wires to support the load. When this occurs, a second counter splayed wire must be added. Install counter splayed wires at an angle equal and opposite to the first wire, but not greater than 45° from vertical. The load capacity of the main beam remains unchanged (refer to ASTM C636).

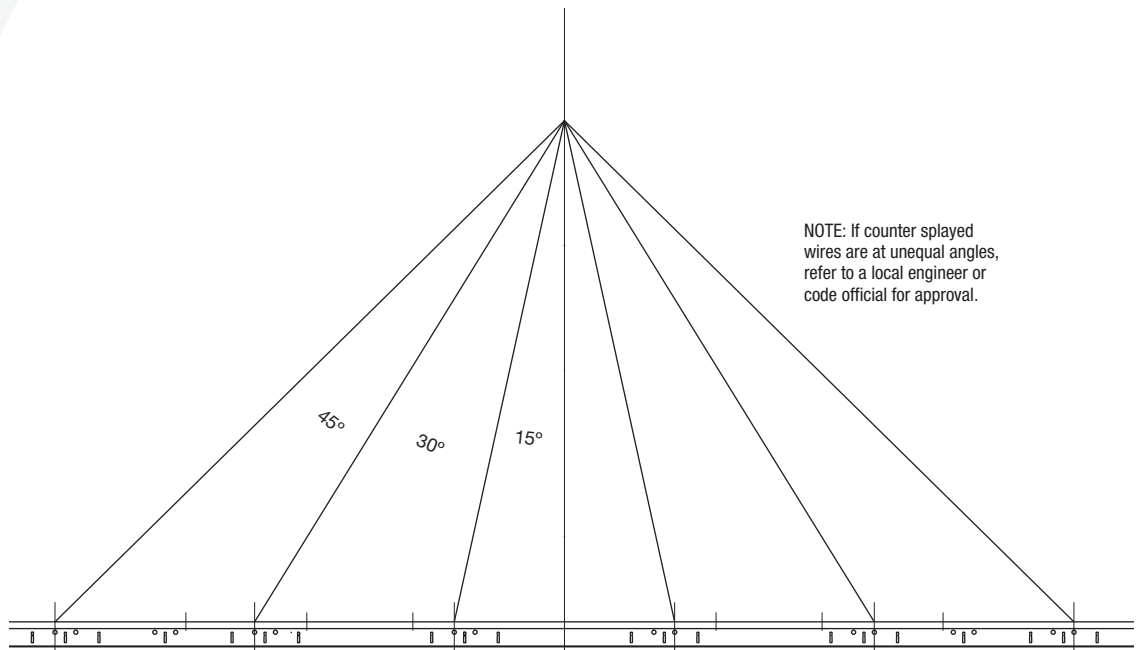

NOTE: If counter splayed wires are at unequal angles, refer to a local engineer or code official for approval.

Another method to install hanger wires around an object in the plenum is to utilize a single or double yoke wire technique.

Rule: To form the 45-degree angle, the vertical location of the tension ring is always half the distance of the span at the structure.

Single Yoke

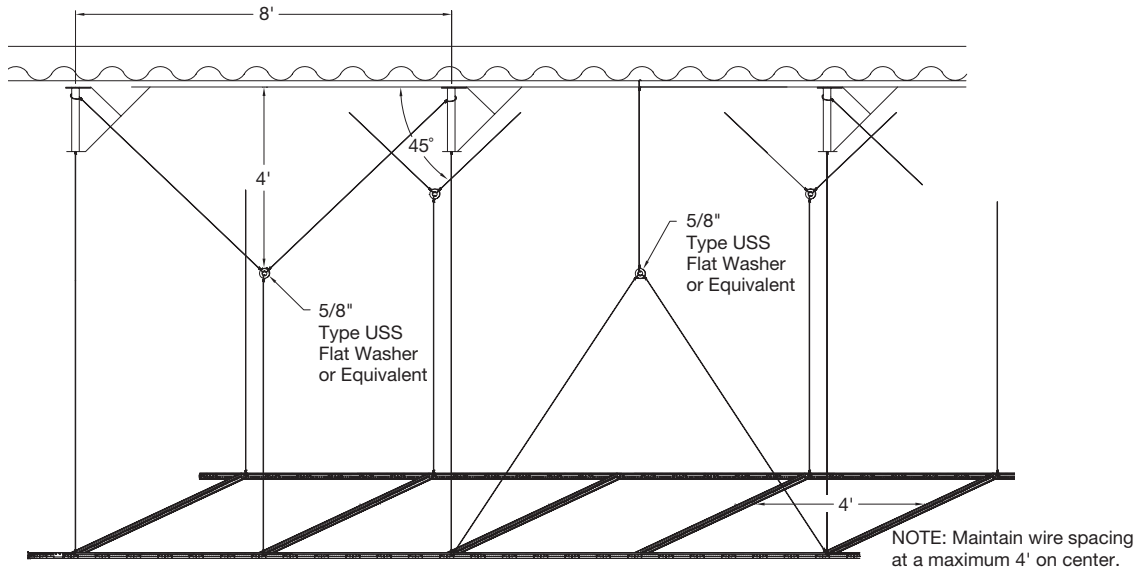

Double Yoke

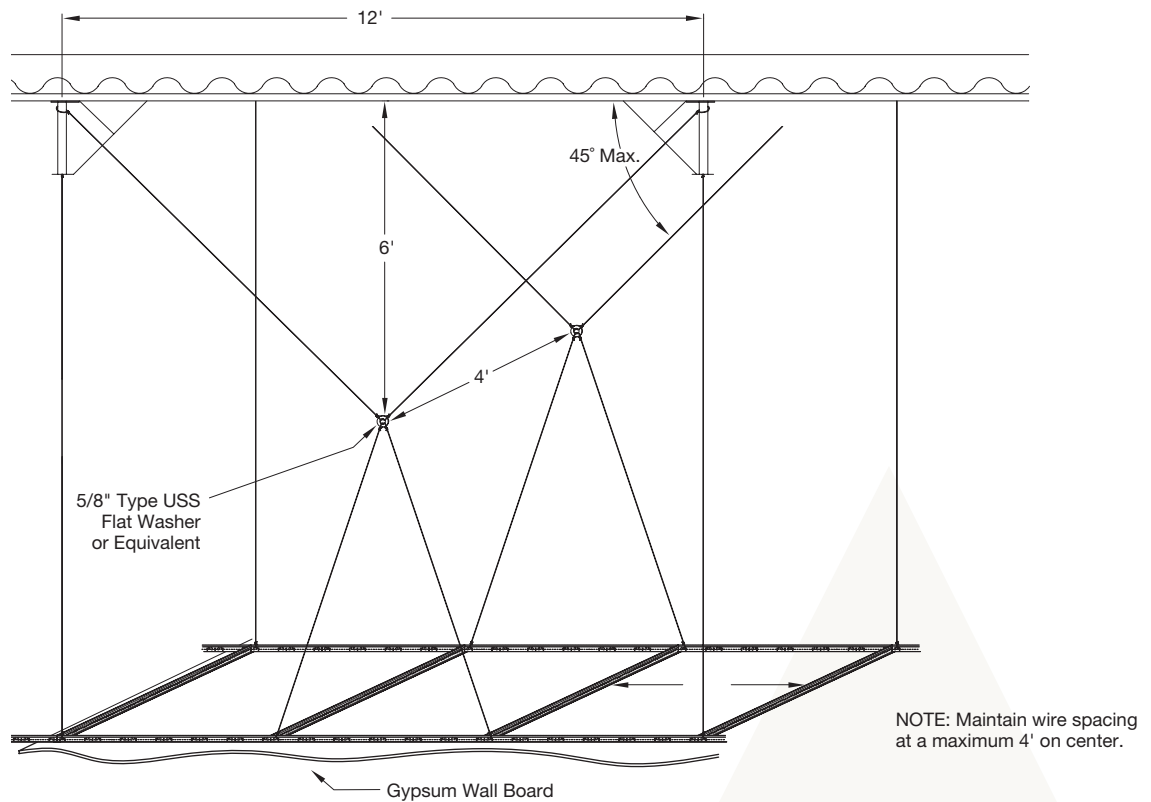

TRAPEZE SUPPORTED LOADS

HANGING & FRAMING

Installing a trapeze is a technique to support multiple hanger wires under obstructions, such as trunk lines, cable trays, or other objects in the plenum. In some cases, the trapeze may affect the ceiling height and must be kept small. In other cases, steel studs may be used to span the distance required.

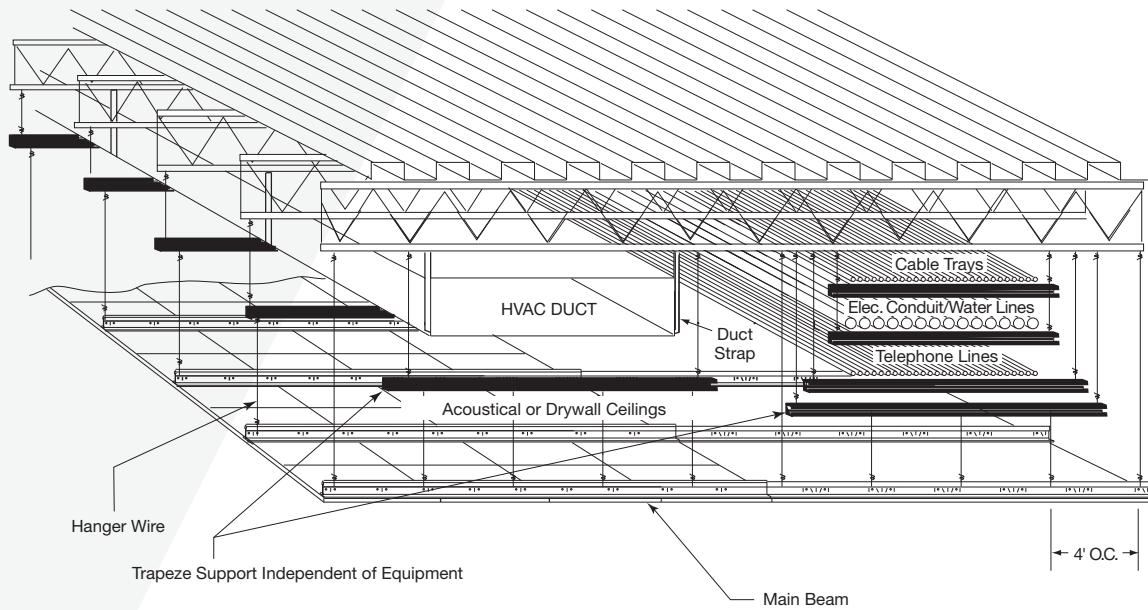

HANGING & FRAMING

A suspended ceiling not only carries the load of the applied finish, but can also act as a load carrying structure or membrane that supports another ceiling at a lower level. The DDC clip is used at hanger wire locations to allow for connecting the second and even third ceiling. This method of hanging and framing is used in multi-layer ceilings with long vertical drops – eliminating the use of long stud drops.

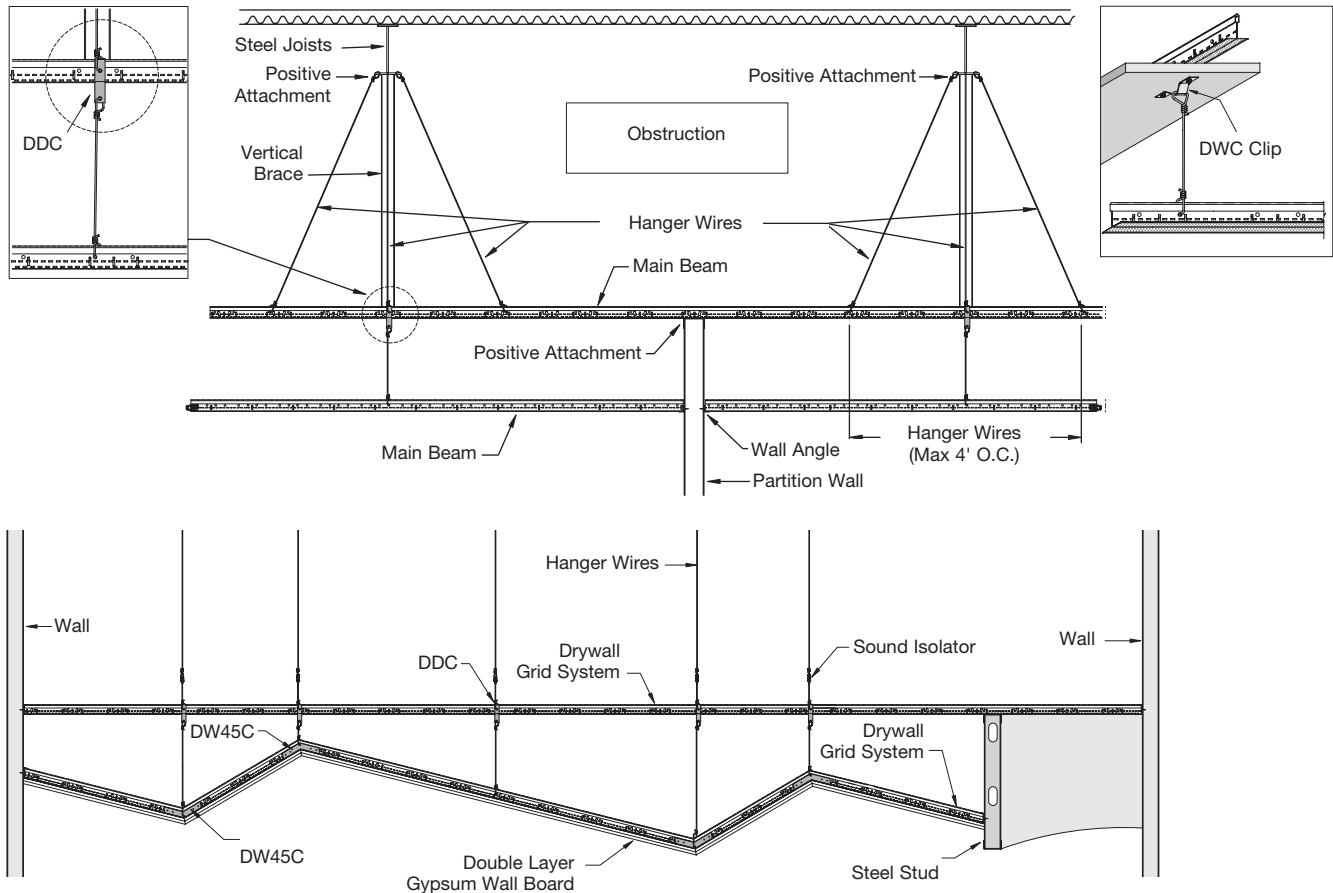

GUSSET HUNG CEILING

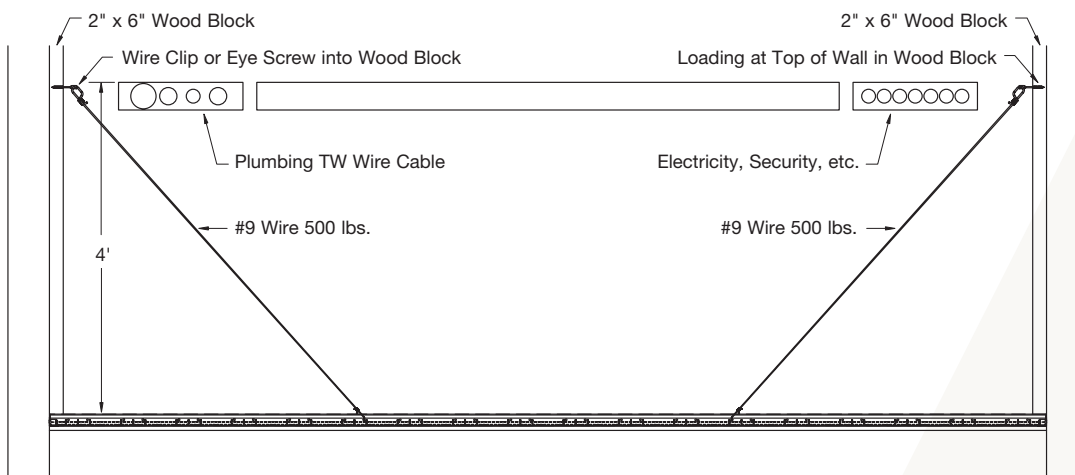

TRIPLE HUNG CEILINGS

HANGING & FRAMING

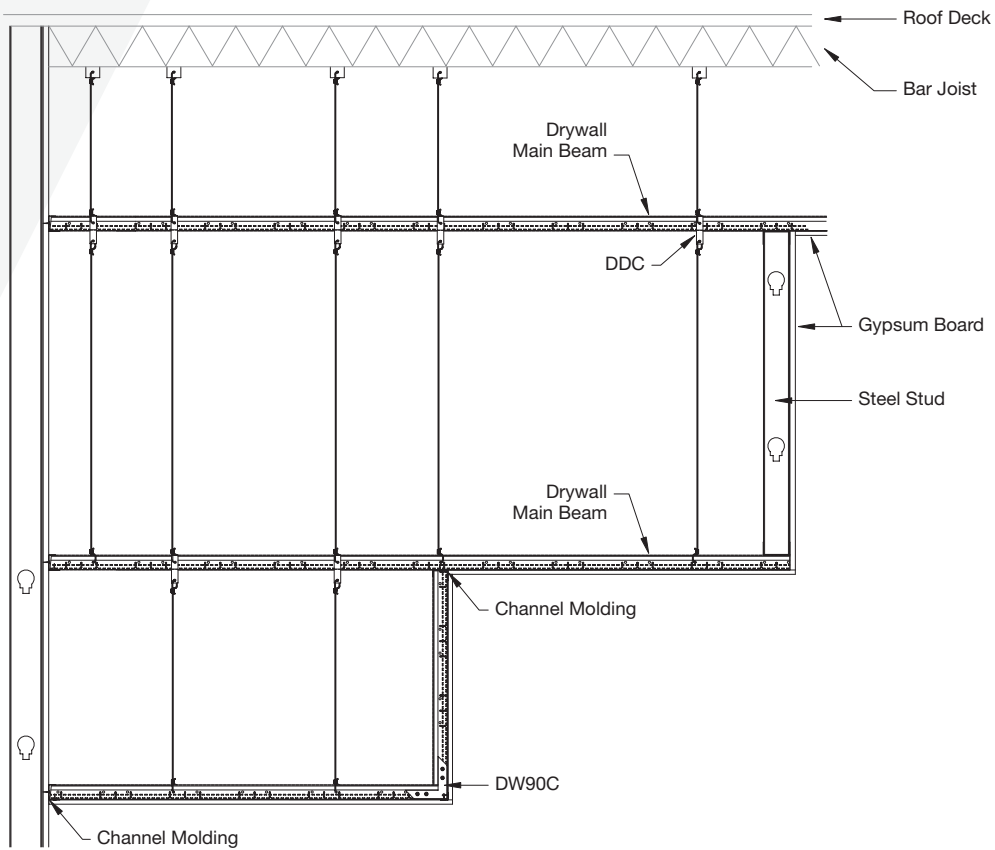
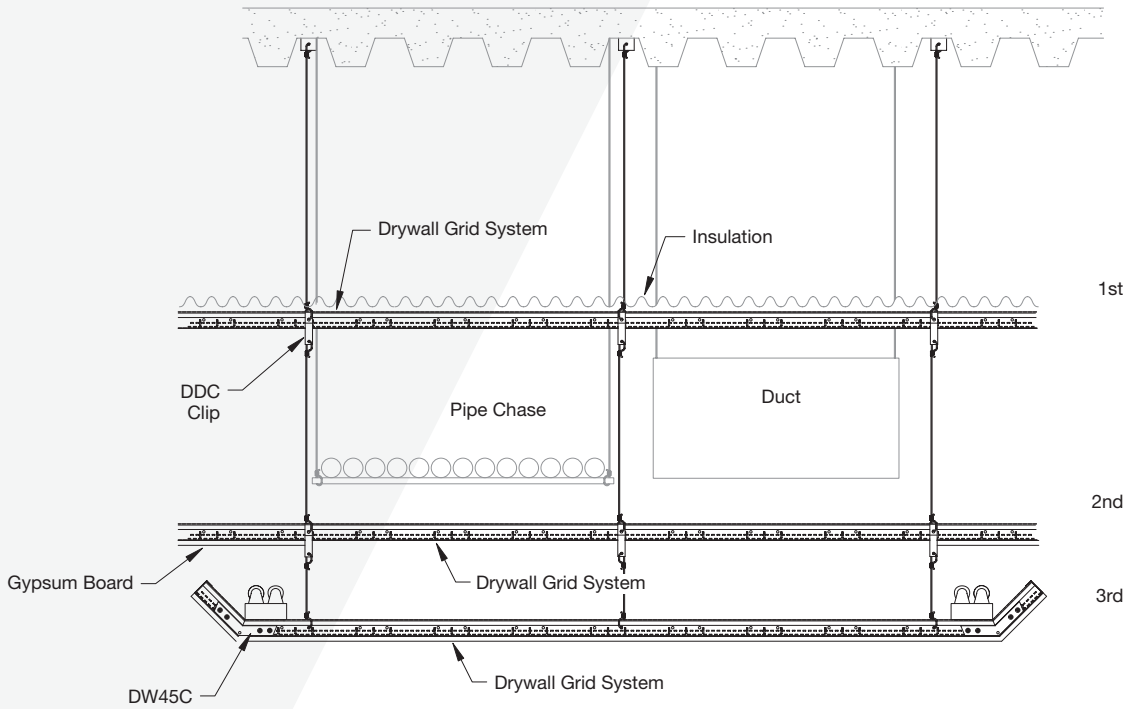

EXTERIOR WIND LOAD DATA

EXTERIOR WIND LOAD CEILING DESIGN FOR NORTH AMERICA

Plenum Height (ft.-in.)	Design Wind Velocity (MPH)	Design Wind Pressure (PSF)	Compression Post Size (Inch)	Compression Post Gauge (Ga. No.)	Sheathing Membrane Substrate 5/8" Drywall Sheet Densglass Gold G-P	Compression Post Spacing (ft.-in.)	Main Beam Spacing (Inch)	Cross Tee Spacing (Inch)	Hanger Wire Spacing (ft.-in.)	Cross Tee Length (Feet)	Compression Post Load Design Load (Lbs.)
0 ↓ 6' ***	15	5.07	2-1/2" CWN	20	5/8" G.P. Densglass & 1/4"-3/8" EIFS	4' 2"	48"	16"	4'	4'	18
	30	2.03	2-1/2" CWN	20	5/8" G.P. Densglass & 1/4"-3/8" EIFS	4' 2"	48"	16"	4'	4'	49
	45	4.56	2-1/2" CWN	20	5/8" G.P. Densglass & 1/4"-3/8" EIFS	3' 6"	48"	16"	4'	4'	96
	60	8.1	2-1/2" CWN	20	5/8" G.P. Densglass & 1/4"-3/8" EIFS	3' 6"	36"	16"	4'	3'	125
	90	18.24	2-1/2" CWN	20	5/8" G.P. Densglass & 1/4"-3/8" EIFS	2' 9"	36"	16"	3'	3'	229
	120	32.43	2-1/2" CWN	20	5/8" G.P. Densglass & 1/4"-3/8" EIFS	2' 8"	24"	16"	2' 6"	2'	266
	140	44.14	2-1/2" CWN	18	5/8" G.P. Densglass & 1/4"-3/8" EIFS	2' 4"	24"	16"	2' 6"	2'	331
	172	75	2-1/2" CSJ	18	See NOA 15-0127.04 Design						
	172	75	2-1/2" CSJ	18	See NOA 14-1204.05 Design						
6' 1" ↓ 10' 3" ****	15	5.07	2-1/2" CSJ	18	5/8" G.P. Densglass & 1/4"-3/8" EIFS	4' 2"	48"	16"	4'	4'	18
	30	2.03	2-1/2" CSJ	18	5/8" G.P. Densglass & 1/4"-3/8" EIFS	3' 10"	48"	16"	4'	4'	49
	45	4.56	2-1/2" CSJ	18	5/8" G.P. Densglass & 1/4"-3/8" EIFS	3' 6"	48"	16"	4'	4'	96
	60	8.1	2-1/2" CSJ	18	5/8" G.P. Densglass & 1/4"-3/8" EIFS	3' 6"	36"	16"	4'	3'	125
	90	18.24	2-1/2" CSJ	18	5/8" G.P. Densglass & 1/4"-3/8" EIFS	3' 4"	36"	16"	3'	2'	178
	120	32.43	2-1/2" CSJ	18	5/8" G.P. Densglass & 1/4"-3/8" EIFS	2' 8"	24"	16"	2' 6"	2'	266
	140	44.14	2-1/2" CSJ	18	5/8" G.P. Densglass & 1/4"-3/8" EIFS	2' 4"	24"	16"	2' 6"	2'	331
	172	75	2-1/2" CSJ	18	See NOA 15-0127.04 Design	2'	24"	16"	2'	2'	445
	172	75	2-1/2" CSJ	18	See NOA 14-1204.05 Design	2' 6"	36"	16"	2' 6"	3'	565
10' 4" ↓ 15' 0" ****	*15	5.07	2-1/2" CSJ	18	5/8" G.P. Densglass & 1/4"-3/8" EIFS	4' 2"	48"	16"	4'	4'	18
	*30	2.03	2-1/2" CSJ	18	5/8" G.P. Densglass & 1/4"-3/8" EIFS	3' 10"	48"	16"	4'	4'	49
	*45	4.56	2-1/2" CSJ	18	5/8" G.P. Densglass & 1/4"-3/8" EIFS	3' 6"	48"	16"	4'	4'	96
	*60	8.1	2-1/2" CSJ	18	5/8" G.P. Densglass & 1/4"-3/8" EIFS	3' 6"	36"	16"	4'	3'	125
	*90	18.24	2-1/2" CSJ	18	5/8" G.P. Densglass & 1/4"-3/8" EIFS	3' 4"	36"	16"	3'	2'	178
	*120	32.43	2-1/2" CSJ	18	5/8" G.P. Densglass & 1/4"-3/8" EIFS	2' 8"	24"	16"	2' 6"	2'	266
	*140	44.14	2-1/2" CSJ	18	5/8" G.P. Densglass & 1/4"-3/8" EIFS	2' 4"	24"	16"	2' 6"	2'	331
	*172	75	2-1/2" CSJ	18	See NOA 15-0127.04 Design	2'	24"	16"	2'	2'	445
	*172	75	2-1/2" CSJ	18	See NOA 14-1204.05 Design	2' 6"	36"	16"	2' 6"	3'	565
15' 1" ↓ 20' 0" ****	**15	5.07	3-5/8" CSJ	18	5/8" G.P. Densglass & 1/4"-3/8" EIFS	4' 2"	48"	16"	4'	4'	18
	**30	2.03	3-5/8" CSJ	18	5/8" G.P. Densglass & 1/4"-3/8" EIFS	3' 10"	48"	16"	4'	4'	49
	**45	4.56	3-5/8" CSJ	18	5/8" G.P. Densglass & 1/4"-3/8" EIFS	3' 6"	48"	16"	4'	4'	96
	**60	8.1	3-5/8" CSJ	18	5/8" G.P. Densglass & 1/4"-3/8" EIFS	3' 6"	36"	16"	4'	3'	125
	**90	18.24	3-5/8" CSJ	18	5/8" G.P. Densglass & 1/4"-3/8" EIFS	3' 4"	36"	16"	3'	2'	178
	**120	32.43	3-5/8" CSJ	18	5/8" G.P. Densglass & 1/4"-3/8" EIFS	2' 8"	24"	16"	2' 6"	2'	266
	**140	44.14	3-5/8" CSJ	18	5/8" G.P. Densglass & 1/4"-3/8" EIFS	2' 4"	24"	16"	2' 6"	2'	331
	**172	75	3-5/8" CSJ	18	See NOA 15-0127.04 Design	2'	24"	16"	2'	2'	445
	**172	75	3-5/8" CSJ	18	See NOA 14-1204.05 Design	2' 6"	36"	16"	2' 6"	3'	565

* 1-1/2" 16 gauge U-Channel Bridging required at mid span for 10'4" up to 15'0"

** 1-1/2" 16 gauge U-Channel Bridging required at one-third points for 15'1" up to 20'0"

*** Compression Post and Ceiling System tested at the plenum design depth shown here for positive and negative wind speed pressure loads as listed

**** Compression Post Assemblies at this plenum design depth calculated by Dietrich Design Group

NOTE: For building heights over 20 feet, refer to ASCE 7-10 Chapter 6 Wind Loads

HANGING & FRAMING

Deck Construction Type	UL® Design Number	Concrete Thickness	# Drywall Layers	Minimum Drywall Thickness	Maximum Fixture Penetration (Ft²/100 Ft²)	Maximum Duct Penetration (In²/100 Ft²)	Drywall Grid System
FLOOR/CEILING DRYWALL ASSEMBLIES							
Concrete on Composite Flat Cellular, Fluted, or Blend Deck							
2-Hour	D501	2-1/2"	1	5/8"	None	None	DFR 8000
	D502**	2-1/2"	1	5/8"	24	144	DFR 8000
Concrete on Metal Lath, Corrugated, and Ribbed Deck							
3-Hour	G523**	3"	1	5/8"	24	144	DFR 8000
	G524***	3-1/2", 3-3/4"	1	1/2"	None	113	DFR 8000
	G529	3-1/4"	1	1/2"	24	57	DFR 8000
	G529	2-3/4"	1	5/8"	24	57	DFR 8000
2-Hour	G523	2-1/2"	1	1/2" or 5/8"*	24	144	DFR 8000
	G524***	3-1/2", 3-3/4"	1	1/2"	None	113	DFR 8000
	G527	2-1/2"	1	1/2" or 5/8"*	None	None	DFR 8000
	G529	2-1/2"	1	1/2"	24	57	DFR 8000
1-1/2-Hour	G528	2-1/2"	1	1/2" or 5/8"*	None	None	DFR 8000
	G524	2-3/4" – 3"	1	1/2" or 5/8"	***	***	DFR 8000
Precast Concrete Slab							
3-Hour	J502	2-3/4"	1	5/8"	None	None	DFR 8000
2-Hour	J502	2"	1	5/8"	None	None	DFR 8000
WOOD DECK/CEILING DRYWALL ASSEMBLIES							
Plywood 2 x 10 Wood Joists							
1-Hour	L502	NA	1	1/2"	None	None	DFR 8000
	L513	NA	1	5/8"	None	None	DFR 8000
	L515	NA	1	1/2"	None	None	DFR 8000
	L525	NA	1	1/2" or 5/8"*	24	57	DFR 8000
	L526**	NA	1	5/8"	24	114	DFR 8000
Plywood (2) 2 x 10 or (1) 4 x 10 Wood Joists							
1-Hour	L508	NA	1	5/8"	None	None	DFR 8000
Plywood with Wood Trusses							
1-Hour	L529	NA	1	5/8"	24	57	DFR 8000

* Depends on rating, manufacturer.

** Optional acoustical tile may be glue-applied to gypsum board.

*** Concrete thickness depends on joist depth used.

HANGING & FRAMING

Deck Construction Type	UL Design Number	Concrete Thickness	# Drywall Layers	Minimum Drywall Thickness	Maximum Fixture Penetration (Ft ² /100 Ft ²)	Maximum Duct Penetration (In ² /100 Ft ²)	Drywall Grid System
DEITRICK TRADEREADY® FLOOR SYSTEM/CEILING DRYWALL ASSEMBLIES							
1-Hour	L564	3/4" Cement Fiber Units	1	5/8"	None	None	DFR 8000
1-Hour Corrugated Decking	G553	3/4"	1	5/8"	None	None	DFR 8000
ROOF/CEILING DRYWALL ASSEMBLIES							
Standing Seam Exposed Metal Roof With Batts/Blankets							
1-Hour	P516	NA	2	5/8"	None	None	DFR 8000
Mineral Fiber, Foam on Cellular, Fluted, Corrugated Metal Deck							
2-Hour	P501	NA	1	5/8"	None	None	DFR 8000
	P514	NA	1	5/8"	24	255	DFR 8000
1-1/2-Hour	P507	NA	1	5/8"	24	57	DFR 8000
	P510	NA	1	5/8"	24	57	DFR 8000
	P513**	NA	1	5/8"	24	144	DFR 8000
1-Hour	P508**	NA	1	5/8"	24	144	DFR 8000
	P509**	NA	1	5/8"	24	144	DFR 8000
	P510	NA	1	1/2"	24	57	DFR 8000
Mineral Fiber/Laminated Gypsum Planks							
1-1/2-Hour	P506	NA	1	5/8"	24	57	DFR 8000

- * Depends on rating, manufacturer.
- ** Optional acoustical tile may be glue-applied to gypsum board.
- *** Concrete thickness depends on joist depth used.

Armstrong® Drywall "Design To Fit" Items XL7936G90 and XL8965 cannot be used as part of a UL Fire Resistive Design. DFR 8000 – UL Designation, Fire Guard™ Drywall Grid System. For fire-rated assemblies, use Type C gypsum board as noted in the UL fire-rated assembly designs.

FIRE RATED EXPANSION JOINT

Fire expansion notch

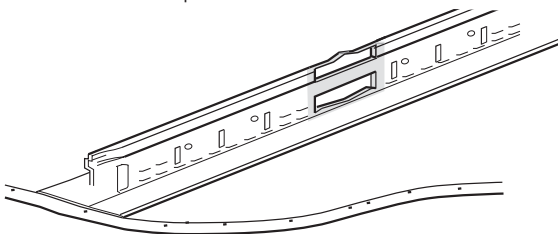

Collapsed fire expansion notch

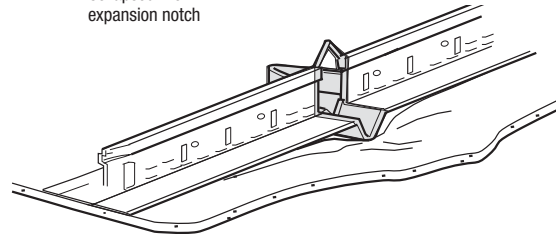

LOAD DATA

MAIN BEAM—TECHNICAL LOAD TEST DATA

IMPERIAL

Item Number	Flange Width (in.)	Length (in.)	Web Height (in.)	Simple Span (Lbs./LF)					
				4'		3'		2'	
				L/240	L/360	L/240	L/360	L/240	L/360
HD8906	1-1/2"	144"	1-11/16"	28.14	18.66	57.3	43.19	143.0	95.5
HD8906 IC	1-1/2"	144"	1-11/16"	28.14	18.66	57.3	43.19	143.0	95.5
HD8906 IO	1-1/2"	120"	1-11/16"	28.14	18.66	57.3	43.19	143.0	95.5

METRIC

Item Number	Flange Width	Length	Web Height	Simple Span (KG/LM)					
				4' (1219.20mm)		3' (914.40mm)		2' (609.60mm)	
				L/240	L/360	L/240	L/360	L/240	L/360
HD7940	38mm	3600mm	43mm	41.65	27.77	96.41	64.27	213.2	142.12
7940G	38mm	3600mm	38mm	31.85	21.24	73.57	49.05	153.8	102.52

CROSS TEES – TECHNICAL LOAD TEST DATA

IMPERIAL

Item Number	Flange Width (in.)	Length (in.)	Web Height (in.)	Simple Span (Lbs./LF)									
				72"		50"		4'		3'		2'	
				L/240	L/360	L/240	L/360	L/240	L/360	L/240	L/360	L/240	L/360
XL8965	1-1/2"	72"	1-1/2"	6.87	4.58								
XL8947P	1-1/2"	50"	1-1/2"			19.5	12.79						
XL8945P	1-1/2"	48"	1-1/2"					22.5	14.27				
XL7936 G90	1-1/2"	36"	1-1/2"							50.0	31.3		
XL8926	1-1/2"	24"	1-1/2"									158.0	90.25

NOTE: Allowable loads tested per ASTM C635 for deflection limited to L/360 and complies with ASTM C645 for deflection limited to L/240. See standards for additional information.

METRIC

Item Number	Flange Width	Length	Web Height	Simple Span (KG/LM)									
				1600mm		1200mm		900mm		600mm			
				L/240	L/360	L/240	L/360	L/240	L/360	L/240	L/360		
XL7961	38mm	1600mm	38mm	0.00	0.00								
XL7930	38mm	1200mm	38mm			0.00	0.00						
XL7925	38mm	900mm	38mm					142.12	96.41				
XL7920	38mm	600mm	38mm									153.78	21.24

MEMBRANE LOAD VALUES

IMPERIAL

Component Combinations		Maximum Load in lbs./ft. ² at Hanger Wire/Cross Tee Spacing					
		48 / 24		48 / 16		36 / 16	
		L/240	L/360	L/240	L/360	L/240	L/360
Main	Cross Tee						
HD8906 – XL8965		3.20		4.66			
HD8906 – XL8947P		6.78	4.52	6.78	4.52	13.41	8.95
HD8906 – XL8945P		7.03	4.69	7.03	4.69	14.93	9.95
HD8901 – XL8945P		6.18	4.12	6.18	4.12	11.61	7.74
HD8906 – XL7936 G90						21.77	14.51
HD8901 – XL7936 G90						21.77	14.51
HD8906 – XL8926						26.13	21.77

METRIC

Component Combinations		Maximum Load in KG/LM ² at Hanger Wire/Cross Tee Spacing					
		1200mm / 600mm		1200mm / 300mm		900mm / 300mm	
		L/240	L/360	L/240	L/360	L/240	L/360
Main	Cross Tee						
HD7940 – XL7961		24.51		26.27			
HD7940 – XL7930		36.37	24.22	36.37	24.22	78.12	56.20
HD7940 – XL7925						112.59	75.04
HD7940 – XL7920						168.59	112.39
7940G – XL7961		20.07		20.07			
7940G – XL7930 G90		27.78	18.50	27.78	18.50	64.35	47.87
7940G – XL7925						85.93	57.27
7940G – XL7920						128.70	85.78

BASIC PRODUCTS USED ON SUSPENSION SYSTEMS

Material	Weight Lbs/SF	Maximum Main Beam Spacing	Maximum Cross Tee Spacing	Maximum Wire Spacing	Load on Wire
OSB 1/4"	0.9	48"	8" – 16"	48"	14.4 Lbs.
3/8"	1.3	48"	16"	48"	20.8 Lbs.
1/2"	1.7	48"	16"	48"	27.2 Lbs.
5/8"	2.2	48"	24"	48"	35.2 Lbs.
3/4"	2.5	48"	24"	48"	40.0 Lbs.
Plywood 1/4"	.075	48"	8" – 16"	48"	12.0 Lbs.
3/8"	1.1	48"	16"	48"	17.6 Lbs.
1/2"	1.5	48"	16"	48"	24.0 Lbs.
5/8"	1.8	48"	24"	48"	28.8 Lbs.
3/4"	2.2	48"	24"	48"	35.2 Lbs.
Gypsum Board 1/4"	1.2	48"	8" – 16"	48"	19.2 Lbs.
3/8"	1.4	48"	16"	48"	22.4 Lbs.
1/2"	2.0	48"	16"	48"	32.0 Lbs.
5/8"	2.4	48"	24"	48"	38.4 Lbs.
3/4"	4.2	48"	16"	48"	67.2 Lbs.
Cement Board 1/2**	3.0	48"	24"	48"	48.0 Lbs.
Cement Siding 5/8**	1.9	48"	16"	48"	30.4 Lbs.
Hard Board Siding 1/2"	2.0	48"	16"	48"	32.0 Lbs.
Water-Resistant Gypsum Board 5/8"	3.42	48"	16" or 24"	48"	57.7 Lbs.
Water-Resistant Gypsum Board 1/2"	2.8	48"	16"	48"	44.8 Lbs.
Expanded Steel Lath	3.4	48"	16"	48"	54.4 Lbs.
12 Gauge Sheet Steel	4.5	48"	16"	48"	72.0 Lbs.

NOTES: All framing on the exterior should be 16" O.C. or less.

Some manufacturers make 1/2" gypsum board with special core to span 24" framing on interior ceiling installations (available on request).

All steel product on exterior made from G90 galvanized finish.

Data based on manufacturer's published data.

* Use lower RPM (1,000-2,500) screw gun to install cement board screws with intermittent pressure.

CONTROL JOINTS

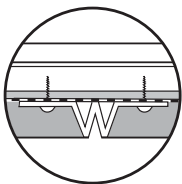

Please refer to ASTM C840, Section 20.3.3 to 20.4 for Control Joint Requirements.

EXPANSION JOINTS

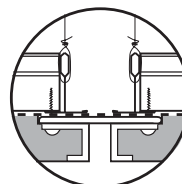

Ceiling expansion joints are installed to separate the metal suspension system when expansion joints occur in buildings or when metal changes direction. Expansion joints are required to separate a system in T-, H-, I-, and U-, or circle-shaped buildings to eliminate cracking from expansion.

SOUND CONTROL

HANGING & FRAMING

The IBC uses two sound classes to measure sound isolation performance in building construction:

Sound Transmission Class (STC) – sound transmitted through the air such as voices and music.

Impact Insulation Class (IIC) – sound transmitted through the building structure such as foot traffic and objects dropped on the floor.

A rating of 50 or above for both STC and IIC sound tests will satisfy the IBC's minimum requirements.

Understanding Sound Control Ratings

STC/IIC Ratings	Description	Changes in STC/IIC Ratings	Description
55	Excellent	+ / - 1	Almost perceptible
50	Loud speech barely audible	+ / - 3	Just perceptible
45	Some loud speech audible – not understood	+ / - 5	Clearly Perceptible
30	Loud speech audible – well understood	+ / - 10	Twice (or half) as loud
25	Regular speech audible and understood through walls		

Satisfy IBC requirements with a rating of 50 or above for STC and IIC sound tests – without two layers of drywall using Armstrong® Drywall Grid.

Traditional Assembly – Field Tested Data

Traditional Assembly	Building Structure	STC	IIC
1-1/2" Black Iron / 7/8" Channel 3-1/2" Batt Insulation 5/8" Gypsum	Bare Concrete Base 3" Concrete Slab Fluted Steel Decking 8" Bar Joist, 24" o.c.	55	48

Armstrong® Standard Drywall Grid Assembly – Field Tested Data

Item Number	Armstrong Assembly	Building Structure	STC	IIC
HD8906 XL8945	12' Main Beam / 4' Cross Tee 3-1/2" Batt Insulation 5/8" Gypsum	Bare Concrete Base 3" Concrete Slab Fluted Steel Decking 8" Bar Joist, 24" o.c.	55	47

Armstrong® IIC Drywall Grid Assembly – Field Tested Data

Item Number	Armstrong® Assembly	Building Structure	STC	IIC
HD8906IIC XL8945 IIC Clip	12' Main Beam / 4' Cross Tee IIC Clip 3-1/2" Batt Insulation 5/8" Gypsum	6" Thick Slab Concrete Base with Vinyl Sheet Flooring	57	66

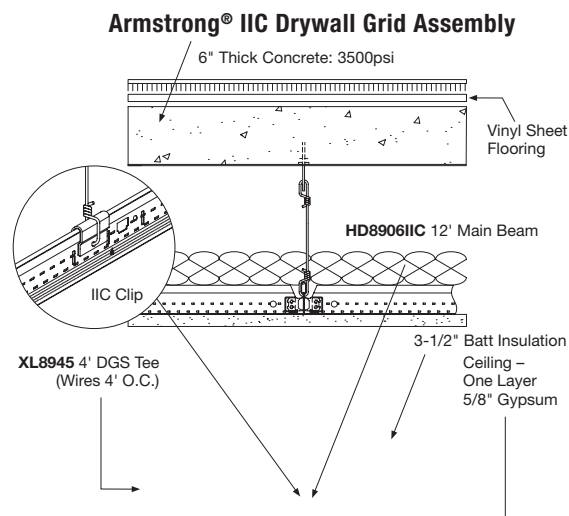

ESTIMATING MATERIAL

Item Number	Length	Pcs/Ctn	LF/Ctn	Lbs./Ctn	Area of ceiling completed by one carton (SF)							
					8" O.C.	16" O.C.	24" O.C.	36" O.C.	48" O.C.	50" O.C.	72" O.C.	
DRYWALL GRID MAIN BEAM												
HD8906/HD8906G90/HD8906IIC	144"	12	144	53			288	432	576	600	864	
HD8906F08/HD8906F16	144"	12	144	53			Varies with radius					
HD890610	120"	12	120	49			288	432	576	600	864	
DRYWALL GRID 1-1/2" FACE CROSS TEES												
XL8965	72"	36	216	78	144	288	432					
XL8947P/XL8947PG90**	50"	36	150	56	100	200	300					
XL8945P/XL8945PG90	48"	36	144	52	96	192	288					
XL7936G90	36"	36	108	39	72	144	216					
XL8926/XL8926G90	24"	36	72	26	48							

** Dimensions are nominal.

Item Number	Length	Pcs/Ctn	LF/Ctn	Lbs/Ctn
REVERSE MOLDINGS				
7857	120"	30	360	51
7858	120"	20	240	67
DRYWALL ANGLE MOLDING				
HD7801G90	120"	30	300	38
KAM-12	144"	20	240	39
KAM-10	120"	20	200	33
LAM-12	144"	20	240	39

Estimating Linear Feet of Grid Based on Square Footage of Ceiling

On-center Spacing of Component	Percent of Square Footage
8"	108%
12"	100%
16"	76%
20"	60%
24"	50%
30"	40%
36"	33%
48"	25%
60"	20%

Example calculation based on 5,100 SF ceiling:

Main beam at 48" O.C.
 $5,100 \text{ SF} \times .25 = 1,275 \text{ LF}$
 $1,275 \text{ LF} \div 144 \text{ LF/Ctn} = 9 \text{ cartons needed}$

Cross tee at 16" O.C.
 $5,100 \text{ SF} \times .76 = 3,876 \text{ LF}$
 $3,876 \text{ LF} \div 144 \text{ LF/Ctn} = 27 \text{ cartons needed}$

Cross tee at 24" O.C.
 $5,100 \text{ SF} \times .50 = 2,550 \text{ LF}$
 $2,550 \text{ LF} \div 144 \text{ LF/Ctn} = 18 \text{ cartons needed}$

877 276-7876

Customer Service Representatives
7:45 a.m. to 5:00 p.m. EST
Monday through Friday

TechLine – Technical information, detail drawings, CAD design assistance, installation information, other technical services – 8:00 a.m. to 5:30 p.m. EST, Monday through Friday. FAX 800 572-8324 or email: techline@armstrongceilings.com

armstrongceilings.com/commercial

Latest product news
Standard and custom product information
Online catalog
CAD, Revit®, SketchUp® files
A Ceiling for Every Space® Visual Selection Tool
Product literature and samples – express service or regular delivery
Contacts – reps, where to buy, who will install

YOU INSPIRE™ SOLUTIONS CENTER

800 988-2585
email: solutionscenter@armstrongceilings.com
armstrongceilings.com/youinspire

Design Assistance

Collaborative design
Detail drawings
Specifications
Planning and budgeting

Pre-construction Assistance

Layout drawings for standard and premium products
Project installation recommendations
Contractor installation assistance

you inspire™
solutions center

helping to bring your one-of-a-kind ideas to life

LEED® is a registered trademark of the U.S. Green Building Council
SketchUp® is a registered trademark of Trimble Navigation Limited; Revit® is a registered trademark of Autodesk, Inc.;
UL® is a registered trademark of UL LLC; TradeReady® is a registered trademark of Clarkwestern Dietrich Building systems LLC;
Inspiring Great Spaces® is a registered trademark of AFI Licensing LLC
All other trademarks used herein are the property of AWI Licensing LLC and/or its affiliates
© 2018 AWI Licensing LLC • Printed in the United States of America

armstrongceilings.com/drywall

Inspiring Great Spaces®

Armstrong®
CEILING SOLUTIONS