

AXTR7902

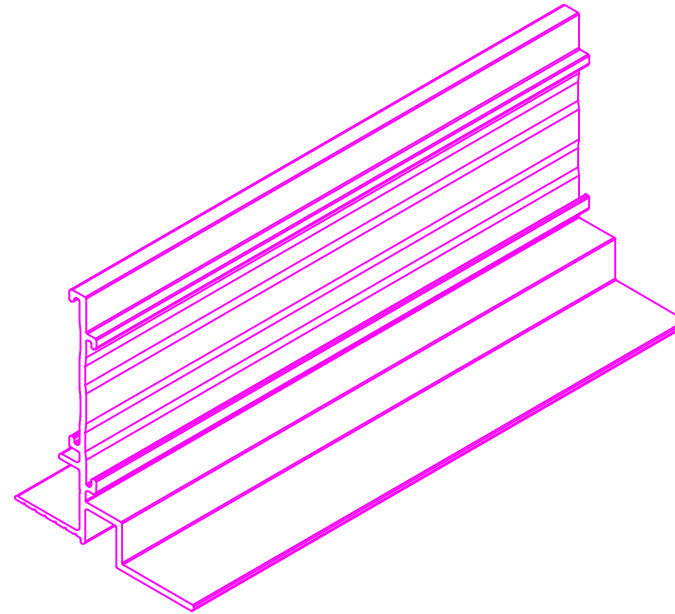
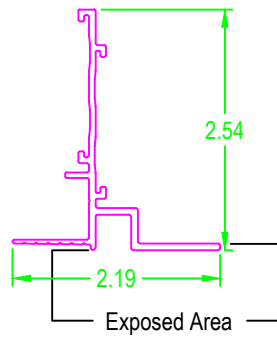

These drawings show typical conditions in which the Armstrong product depicted is installed. They are not a substitute for an architect's or engineer's plan and do not reflect the unique requirements of local building codes, laws, statutes, ordinances, rules and regulations (Legal Requirements) that may be applicable for a particular installation.

Armstrong does not warrant, and assumes no liability for the accuracy or completeness of the drawings for a particular installation or their fitness for a particular purpose.

The user is advised to consult with a duly licensed architect or engineer in the particular locale of the installation to assure compliance with all Legal Requirements.

Armstrong is not licensed to provide professional architecture or engineering design services.

PROJECT NAME: **AXIOM TRANSITIONS**
15/16" SHADOW REVEAL STRAIGHT TRANSITION

DWG. NO. AXTR7902STR		REV: .	DATE: .
DATE: 7/20/15	SCALE:	DESC.: .	
DRAWN BY: MSS	CHK BY:	.	