

Locking Angle Molding Details (LAM-12 patent pending)

Installation Notes:

- ShortSpan tees must be cut within $\frac{1}{8}$ " of the vertical leg of the Locking Angle Moldings (For non-Fire Rated Installations)
- Must Screw LAM-12 and KAM-12 to wall structure (#8 x 1-1/4" wafer head self drill sheet metal screws tested in 25 and 20 gauge steel stud)
 - Assembly tested to 200 lbs. per connection for shear and screw pullout failure.
- Locking Angle Molding is designed to only work with Armstrong Drywall Grid products.

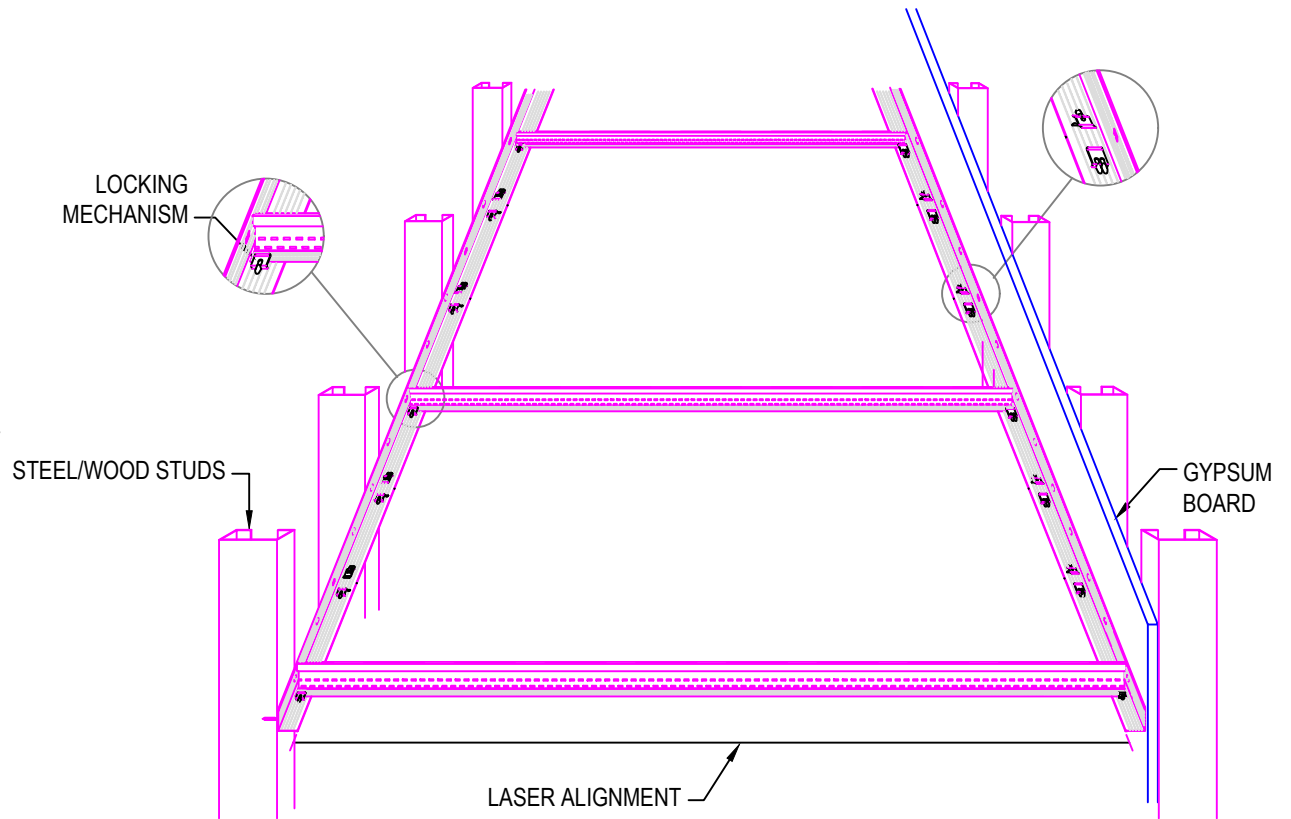

These drawings show typical conditions in which the Armstrong product depicted is installed. They are not a substitute for an architect's or engineer's plan and do not reflect the unique requirements of local building codes, laws, statutes, ordinances, rules and regulations (Legal Requirements) that may be applicable for a particular installation.

Armstrong does not warrant, and assumes no liability for the accuracy or completeness of the drawings for a particular installation or their fitness for a particular purpose. The user is advised to consult with a duly licensed architect or engineer in the particular locale of the installation to assure compliance with all Legal Requirements.

Armstrong is not licensed to provide professional architecture or engineering design services.

| | | | |
|--|--------------------|----------|---------|
| PROJECT NAME: Locking Angle Molding Application | | | |
| DWG. NO. 2-46 | PATH: . | REV: . | DATE: . |
| DATE: 10/11/22 | SCALE: 1:12 | DESC.: . | |
| DRAWN BY: MAP | CHK BY: . | | |



CEILING SYSTEMS * ARMSTRONG WORLD INDUSTRIES, INC. * Lancaster, PA * Phone: 877-ARMSTRONG