



CONFIDENTIAL
 ALL INFORMATION SHOWN IN THIS DOCUMENT
 TOGETHER WITH RELATED METHODS AND
 MANUFACTURING PROCESSES, ARE THE
 EXCLUSIVE PROPERTY OF
 WORTHINGTON ARMSTRONG VENTURE

**MACHINING TOLERANCES
 EXCEPT AS NOTED:**

FRACTIONAL ± 1/64"
 .XX ± 0.005"
 .XXX ± 0.001"
 .XXXX ± 0.0002"
 ANGULAR ± 1/4°

BREAK ALL SHARP EDGES & CORNERS
 MAT'L:

 WAVE WORTHINGTON ARMSTRONG VENTURE <small>CORPORATE ENGINEERING: 101 LINDEWOOD DRIVE, SUITE 350, MALVERN, PA 19355</small>	
2" BERC CLIP V4, (ITEM # BERC2) SEISMIC TESTED 2/09	
DRAWN BY: R.KHAN EST. WEIGHT: 0.091 lbmass	DATE: 12/16/2021 DATE: 2/22/2008  THIRD ANGLE PROJECTION REV. K
BERC2 CLIP	

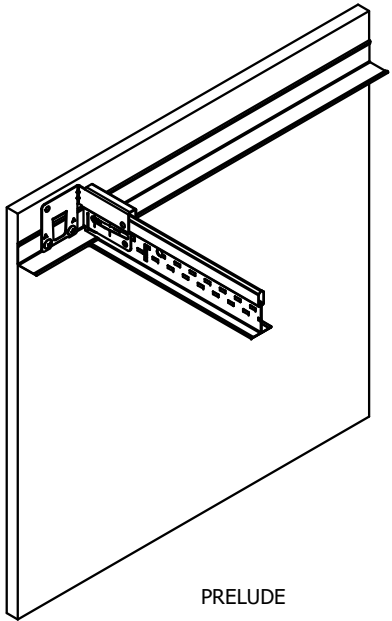

PRELUDE

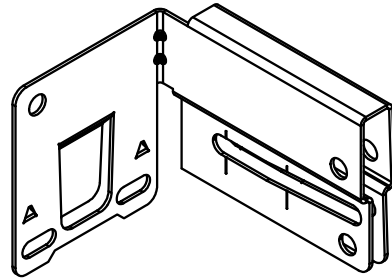

SILHOUETTE

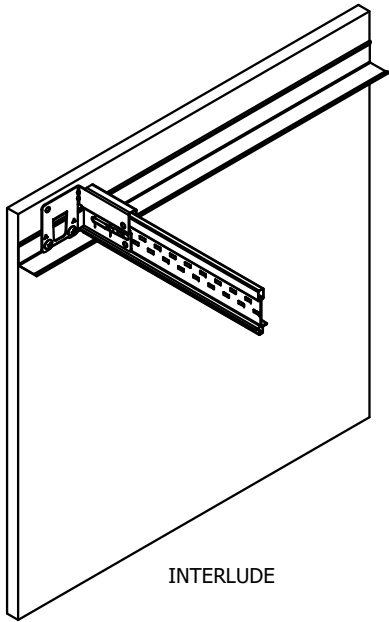

INTERLUDE

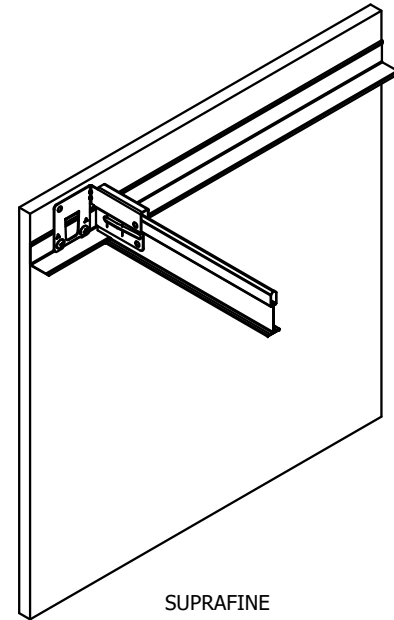

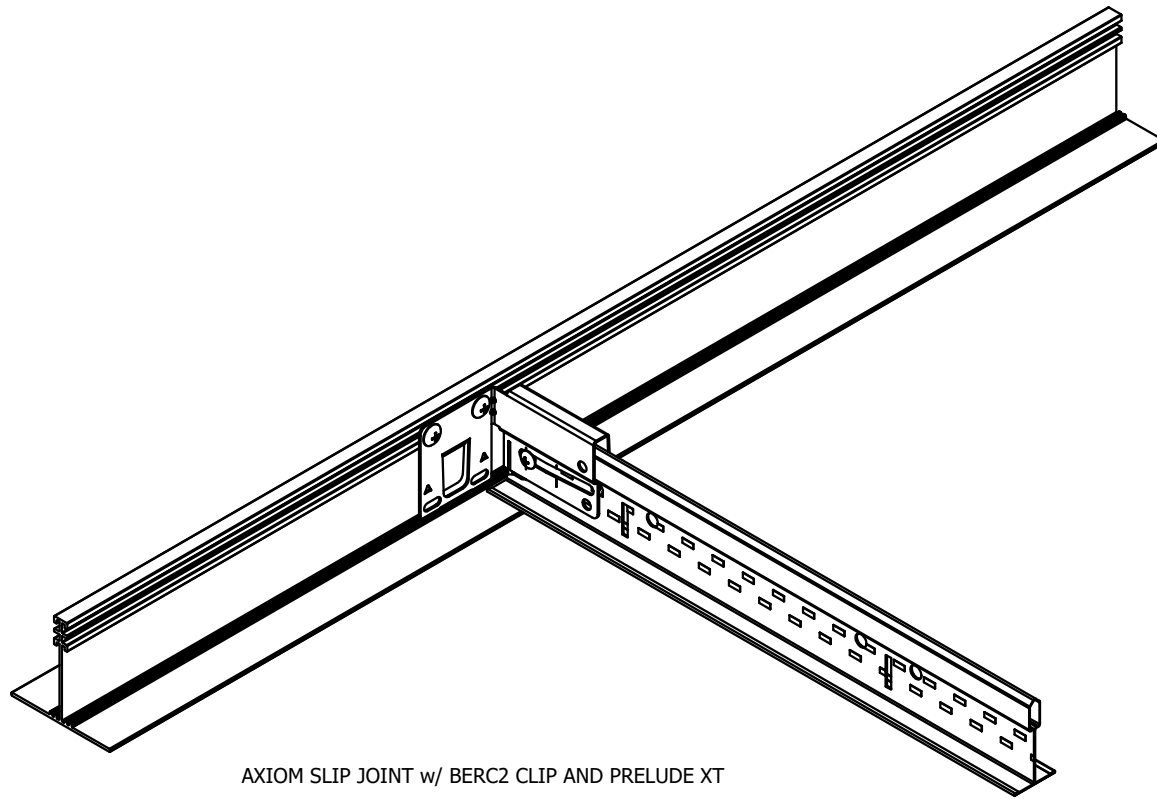

SUPRAFINE

 <small>WAVE TECHNOLOGY AND SYSTEMS, INC.</small> <small>CONCEPT ENGINEERING, ALL INFORMATION IS SUBJECT TO CHANGE WITHOUT NOTICE</small>	
2" BERCLIP V4, (ITEM # BERCLIP2) SEISMIC TESTED 2/09	
DESIGNED BY: R.KHAN	DATE: 12/18/2002
DESIGNED BY: B. SAREYKA	DATE: 2/22/2009
REV. 1	REV. K
BERCLIP	



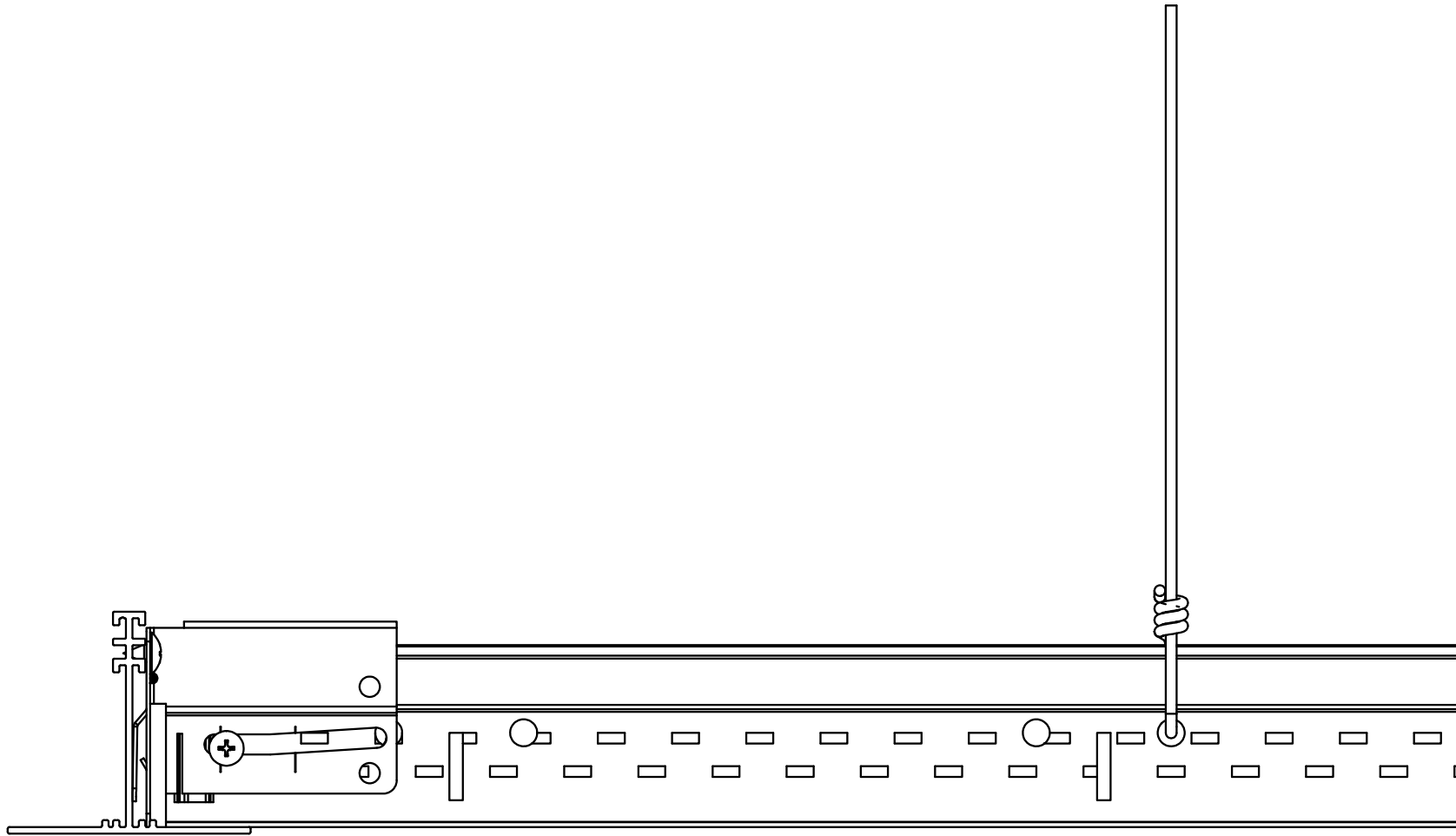

AXIOM SLIP JOINT w/ BERC2 CLIP AND PRELUDE XT

 <small>WAVE</small> <small>WAVE TECHNOLOGICAL SERVICES INC.</small> <small>CONCEPT ENGINEERING, ALL INFORMATION IS SUBJECT TO OUR TERMS AND CONDITIONS</small>			
From the IProperties Title From the IProperties Subject			
<small>DESIGNED BY:</small> R.KHAN	<small>DATE:</small> 12/16/2021		<small>REV.</small>
<small>FILE NUMBER:</small>	<small>1-1700-000000</small>	AXSJ_BERC2_APP	





AXIOM SLIP JOINT w/ BERC2 CLIP AND PRELUDE XT (WITH HANGER WIRE)

 <small>WAVE</small> <small>WAVE TECHNOLOGY GROUP, INC.</small> <small>CONCEPT ENGINEERING, ALL INFORMATION IS UNCLASSIFIED UNLESS INDICATED OTHERWISE</small>			
From the IPProperties Title From the IPProperties Subject			
<small>DESIGNED BY:</small> R.KHAN	<small>DATE:</small> 12/16/2021		<small>REV.</small>
<small>DESIGNED BY:</small> R.KHAN	<small>DATE:</small> 12/16/2021		
<small>REV:</small> 1. 12/16/2021			

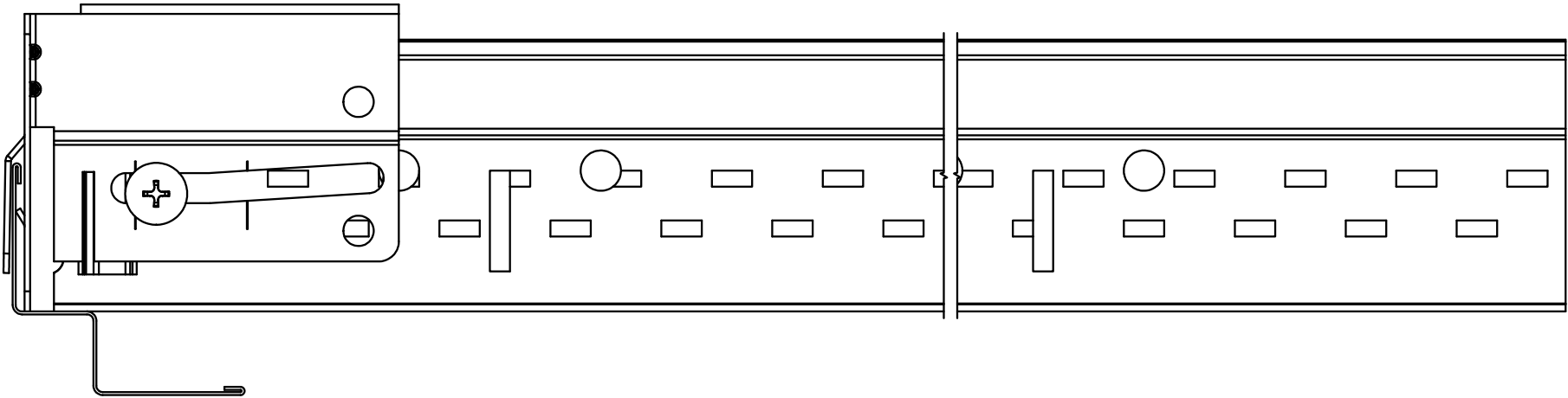
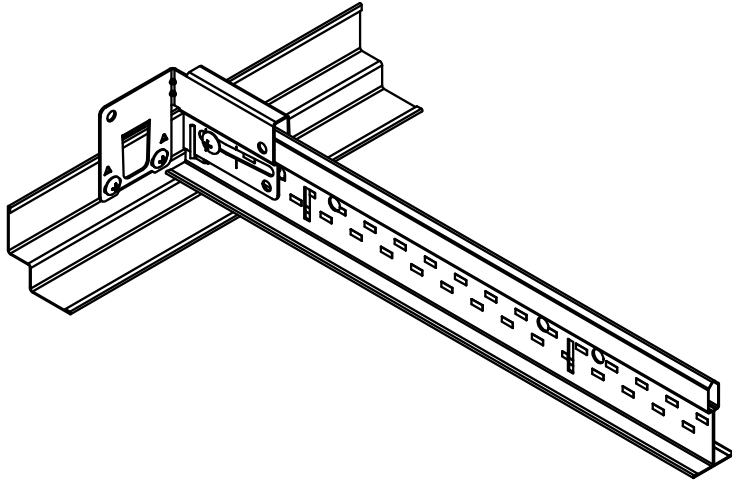
AXSJ_BERC2_APP



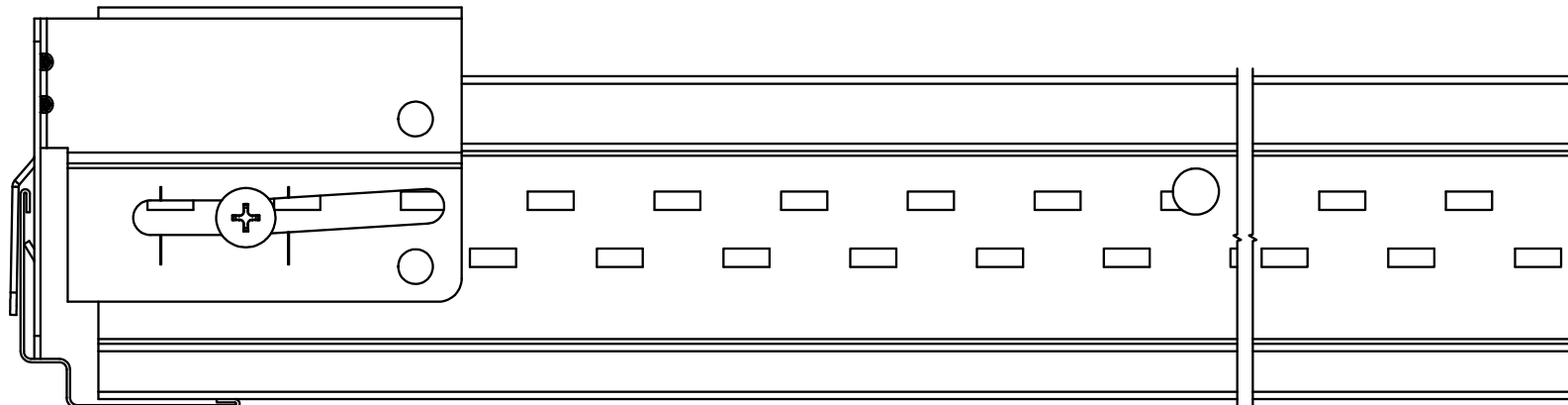

PRELUDE GRID WITH 7897 SHADOW MOLDING AND BERC2 CLIP

 <small>WAVE TECHNOLOGIES INC. 10000 WAVE DRIVE, SUITE 100, WILLOW GROVE, IL 60090</small>		
DESIGNED BY: R.KHAN	DATE: 12/18/2021	REV. 
DRAWN BY: R.KHAN	DATE:	
0.214 kg		PRELUDE_7897&BERC2



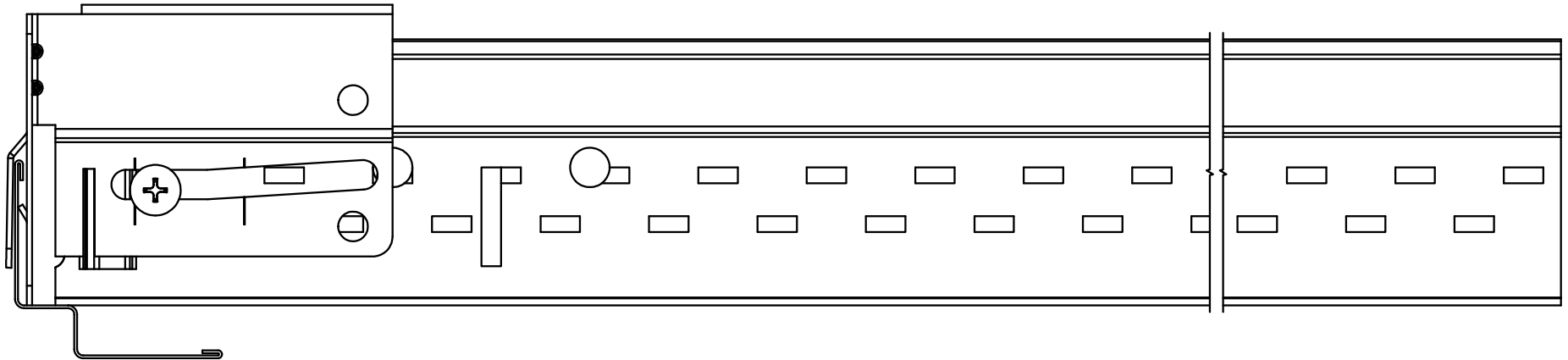

SILHOUETTE GRID WITH 7877 SHADOW MOLDING AND BERC2 CLIP

 <small>WAVE</small> <small>WAVE TECHNOLOGIES INC.</small> <small>CONCEPT ENGINEERING ALL INFORMATION IS UNCLASSIFIED UNLESS INDICATED OTHERWISE</small>		
DESIGNED BY: R.KHAN	DATE: 12/18/2021	REV.
DRAWN BY: 0.204 kg	DATE:	REV.
		
SILHOUETTE_7877		



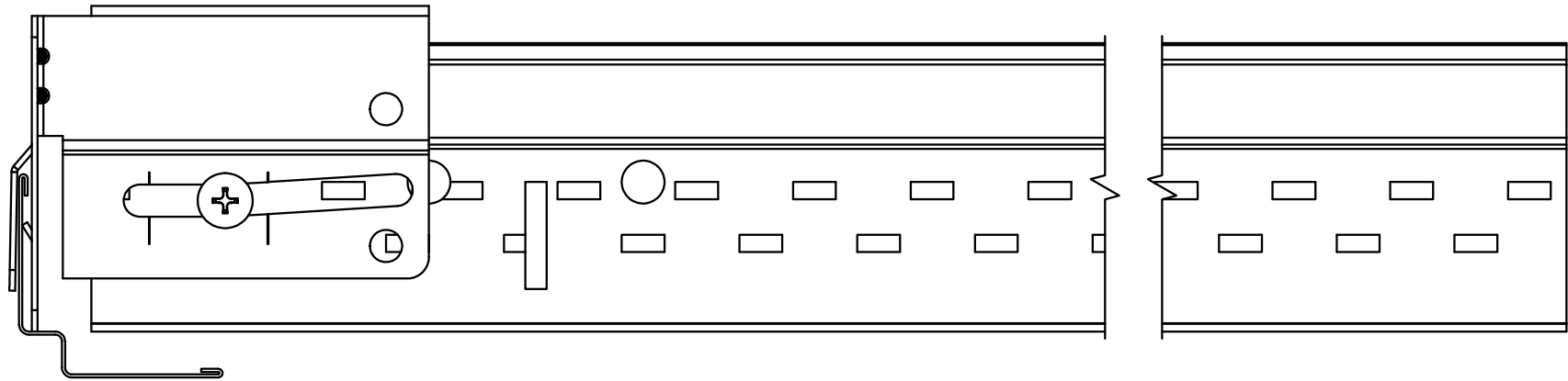

PRELUDE GRID WITH 7878 SHADOW MOLDING AND BERC2 CLIP

 <small>WAVE TECHNOLOGY CORPORATION</small> <small>CONCEPT ENGINEERING ALL INFORMATION IS UNCLASSIFIED UNLESS INDICATED OTHERWISE</small>			REV.
DESIGNED BY: R.KHAN	DATE: 12/18/2021		
DRAWN BY: 0.162 kg			
PRELUDE_7878&B			



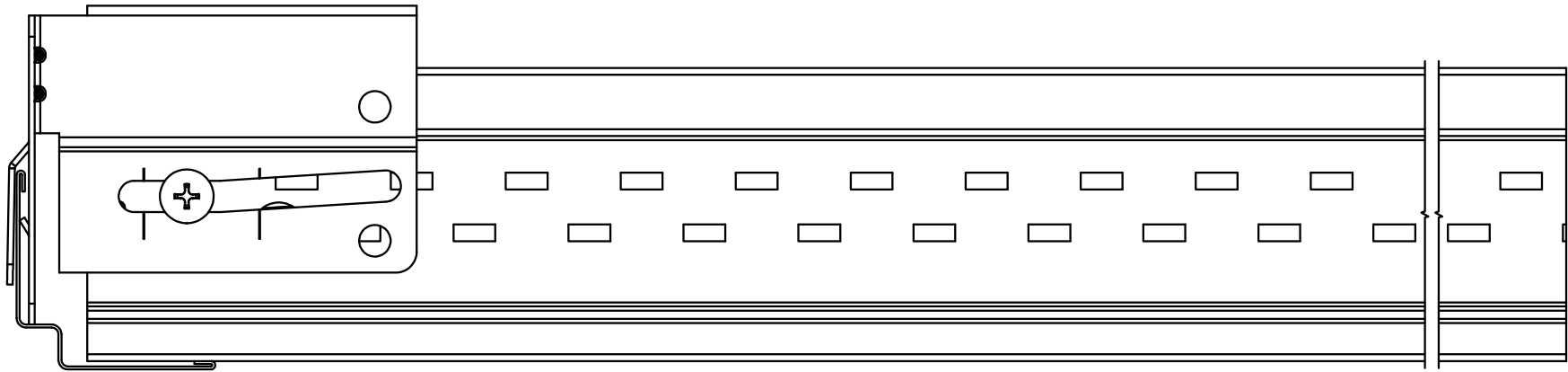

PRELUDE GRID_WITH 7877 SHADOW MOLDING AND BERC2 CLIP

 <small>WAVE</small> <small>WAVE TECHNOLOGIES</small> <small>CONCEPT ENGINEERING ALL INFORMATION IS UNCLASSIFIED UNLESS INDICATED OTHERWISE</small>			REV.
DESIGNED BY: R.KHAN	DATE: 12/18/2021		REV.
DESIGNED BY: R.KHAN	DATE:		
DATE: 01/20/2022			
PRELUDE_7877&BERC2			



INTERLUDE GRID WITH 7877 SHADOW MOLDING AND BERC2 CLIP

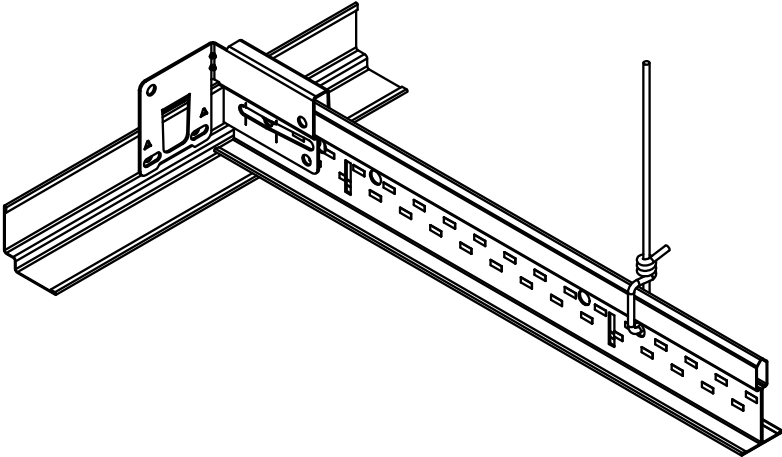

 <small>WAVE</small> <small>WAVE TECHNOLOGIES PRIVATE LIMITED</small> <small>CONCEPT ENGINEERING ALL INFORMATION IS CONFIDENTIAL</small>		
DESIGNED BY: R.KHAN	DATE: 12/16/2021	REV.
DRAWN BY: 0.102 MB		
		
INTERLUDE_78778		

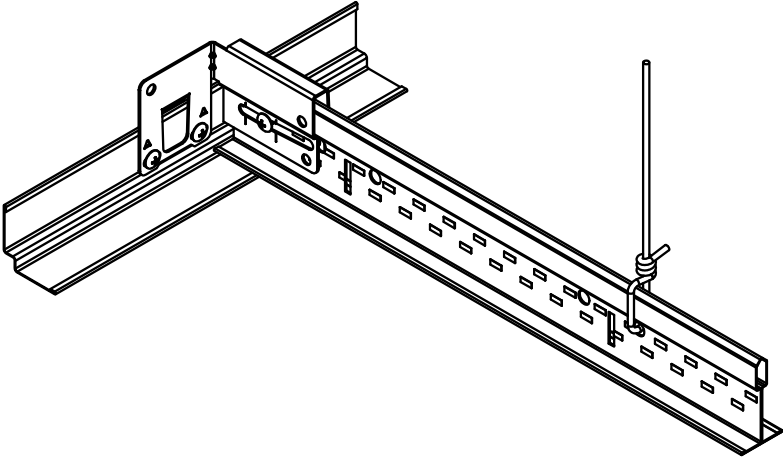

UNATTACHED WALL



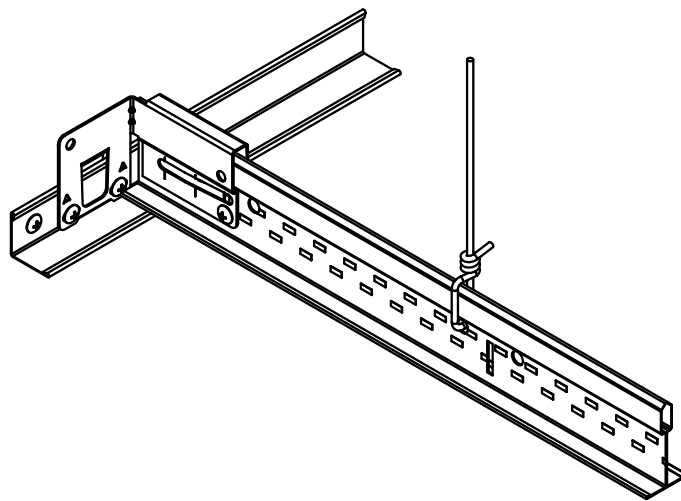

ATTACHED WALL

 <small>WAVE TECHNOLOGY AND SERVICES PVT. LTD.</small> <small>CONCEPT ENGINEERING ALL APPROVED DRAWINGS ARE RELEASED BY USER</small>			
DESIGN BY: R.KHAN	DATE: 12/18/2021		REV.
DESIGNED BY: R.KHAN	DATE:		
D:\2021\12\18\2021\PRELUDE_7877&BERC2_1			

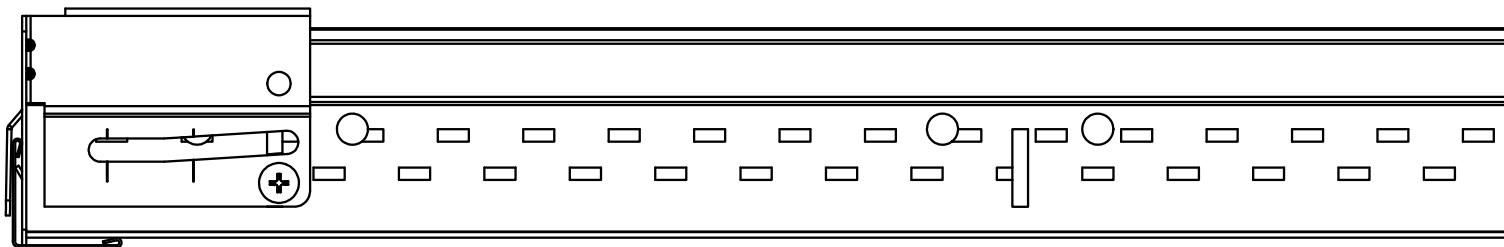

ATTACHED WALL



 <small>WAVE ENGINEERING & CONSULTING SERVICES</small> <small>CONSULTING ENGINEERING AND ARCHITECTURAL DESIGN AND SERVICES PVT. LTD.</small>			
DESIGNED BY: R.KHAN	DATE: 12/18/2021		REV.
DRAWN BY: 0.100 kg			
PRELUDE_7800&BE			

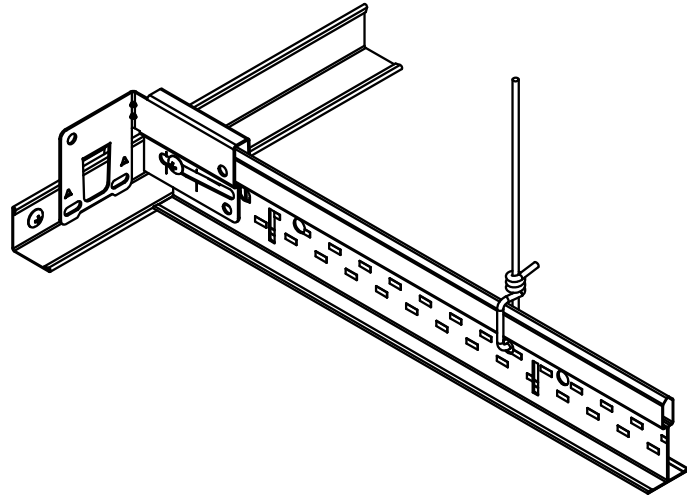

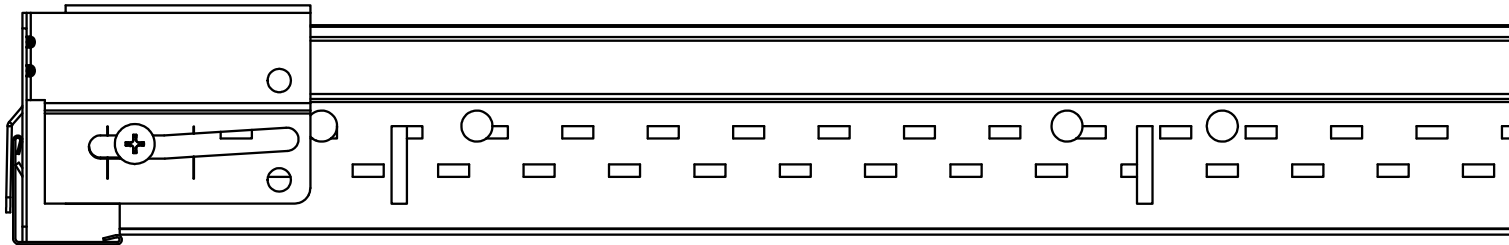

UNATTACHED WALL

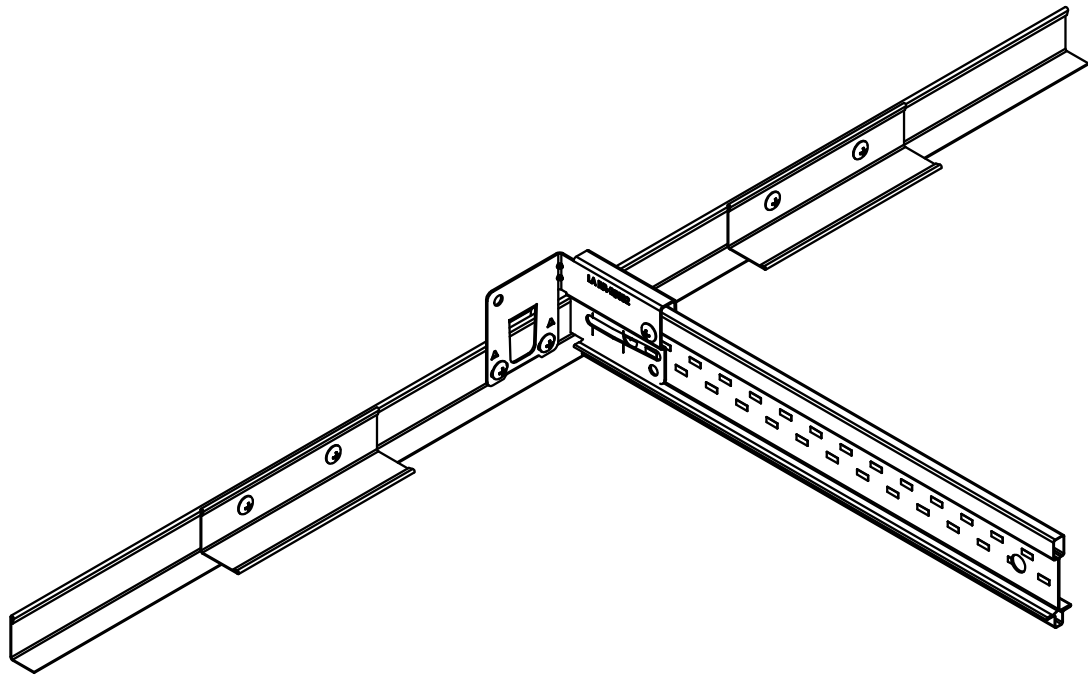

 WAVE WAVE TECHNOLOGY AND SERVICES PVT. LTD. CORPORATE HEADQUARTERS: 411, ANANDAPUR ROAD, SECTOR 15, GURGAON, HARYANA		
DESIGNED BY: R.KHAN	DATE: 12/18/2021	REV.
DESIGNED BY: R.KHAN	DATE:	
0_DWG SET		
PRELUDE_7800&BERC		



 WAVE WAVE TECHNOLOGY AND SERVICES PVT. LTD. CORPORATE ENGINEERING, ALL ENGINEERING DESIGNS ARE RELEASED BY WAVE		
DESIGNED BY: R.KHAN	DATE: 12/18/2023	REV.
DESIGNED BY: R.KHAN	DATE:	
DATE: 01/24/24	BERC2 WITH HOLD	

C:\na\wp_2023\04\NEW PRODUCT DEVELOPMENT\MARKETING LITERATURE\BERC2 UPDATE 0223\BERC2