

SHORTSPAN MASTER SHEET LEGEND

SHEET #	DETAIL #	DRAWING
1	A-01-MS-01	MASTER SHEET
2	A-01-MS-02	SHORTSPAN AT PERIMETER WALL
3	A-01-MS-03	SHORTSPAN LOW PROFILE AT PERIMETER WALL
4	A-01-MS-04	SHORTSPAN WITH STRONGBACK SPLICE APPLICATION
5	A-01-MS-05	SHORTSPAN AT WALL
6	A-01-MS-06	SHORTSPAN INTERSECTION CORRIDORS WITH I-BEAM GIRDER
7	A-01-MS-07	SHORTSPAN WITH STRONGBACK APPLICATION
8	A-01-MS-08	SHORTSPAN LAYOUT WITH 9'-0" SPAN
9	A-01-MS-09	SHORTSPAN LAYOUT WITH 8'-0" SPAN
10	A-01-MS-10	SHORTSPAN LAYOUT WITH 14' SPAN 16" O.C.
11	A-01-MS-11	SHORTSPAN LAYOUT WITH 14' SPAN 24" O.C.

These drawings show typical conditions in which the Armstrong product depicted is installed. They are not a substitute for an architect's or engineer's plan and do not reflect the unique requirements of local building codes, laws, statutes, ordinances, rules and regulations (Legal Requirements) that may be applicable for a particular installation.

Armstrong does not warrant, and assumes no liability for the accuracy or completeness of the drawings for a particular installation or their fitness for a particular purpose. The user is advised to consult with a duly licensed architect or engineer in the particular locale of the installation to assure compliance with all Legal Requirements.

Armstrong is not licensed to provide professional architecture or engineering design services.

PROJECT NAME:		SHORTSPAN MASTER SHEET	
DWG. NO. A-01-MS-00		REV: .	DATE: .
DATE: 4/12/24	SCALE: .	DESC.: .	
DRAWN BY: MAP	CHK BY: .		



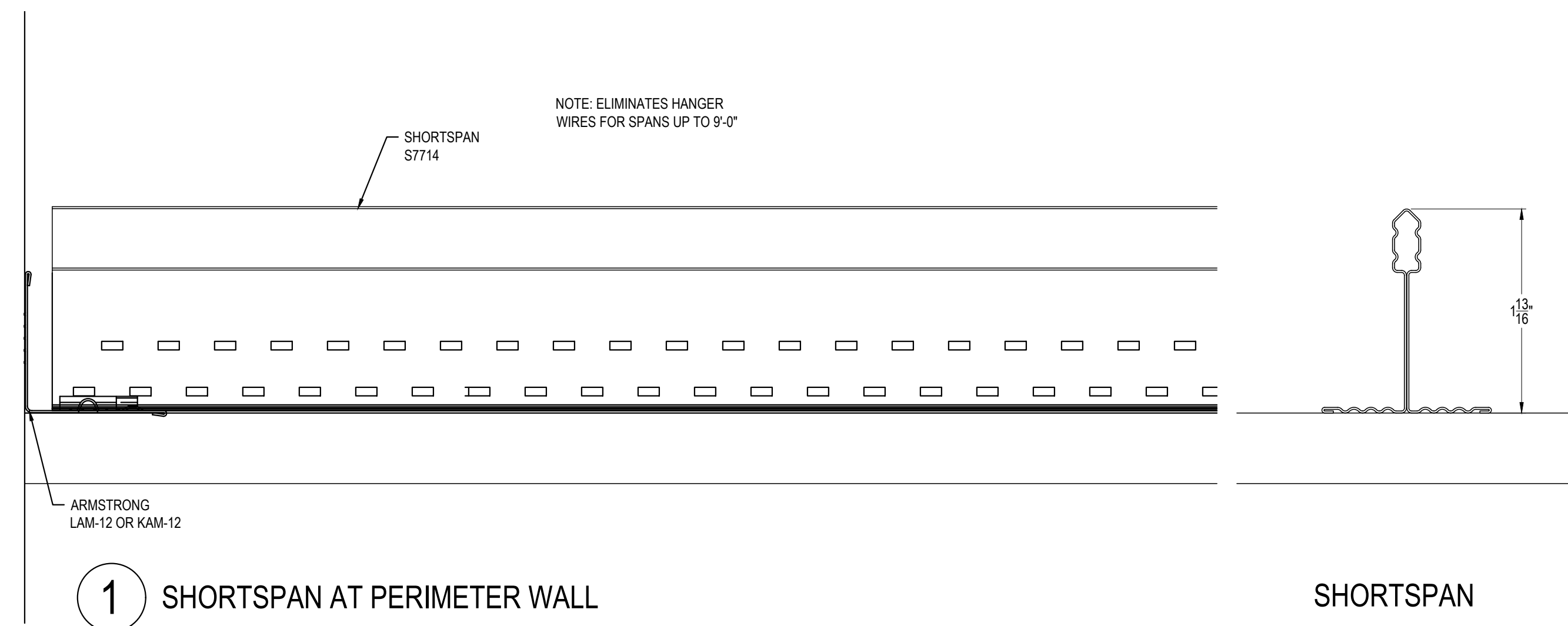

1 SHORTSPAN AT PERIMETER WALL

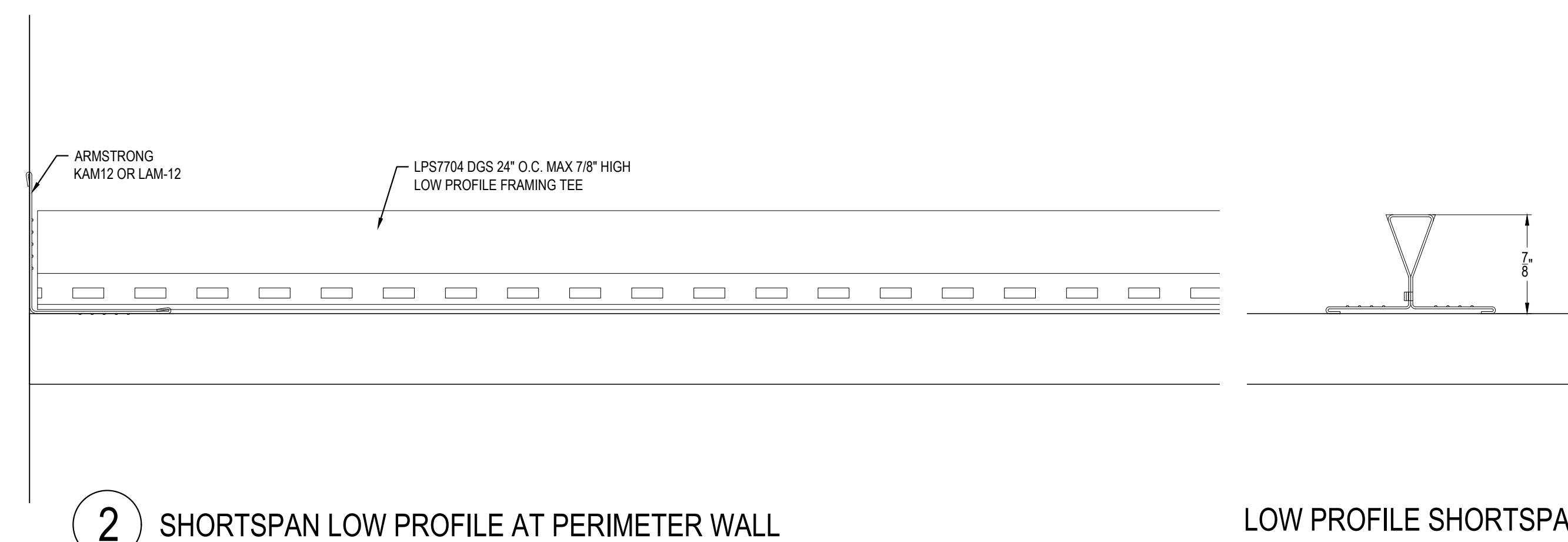

2 SHORTSPAN LOW PROFILE AT PERIMETER WALL

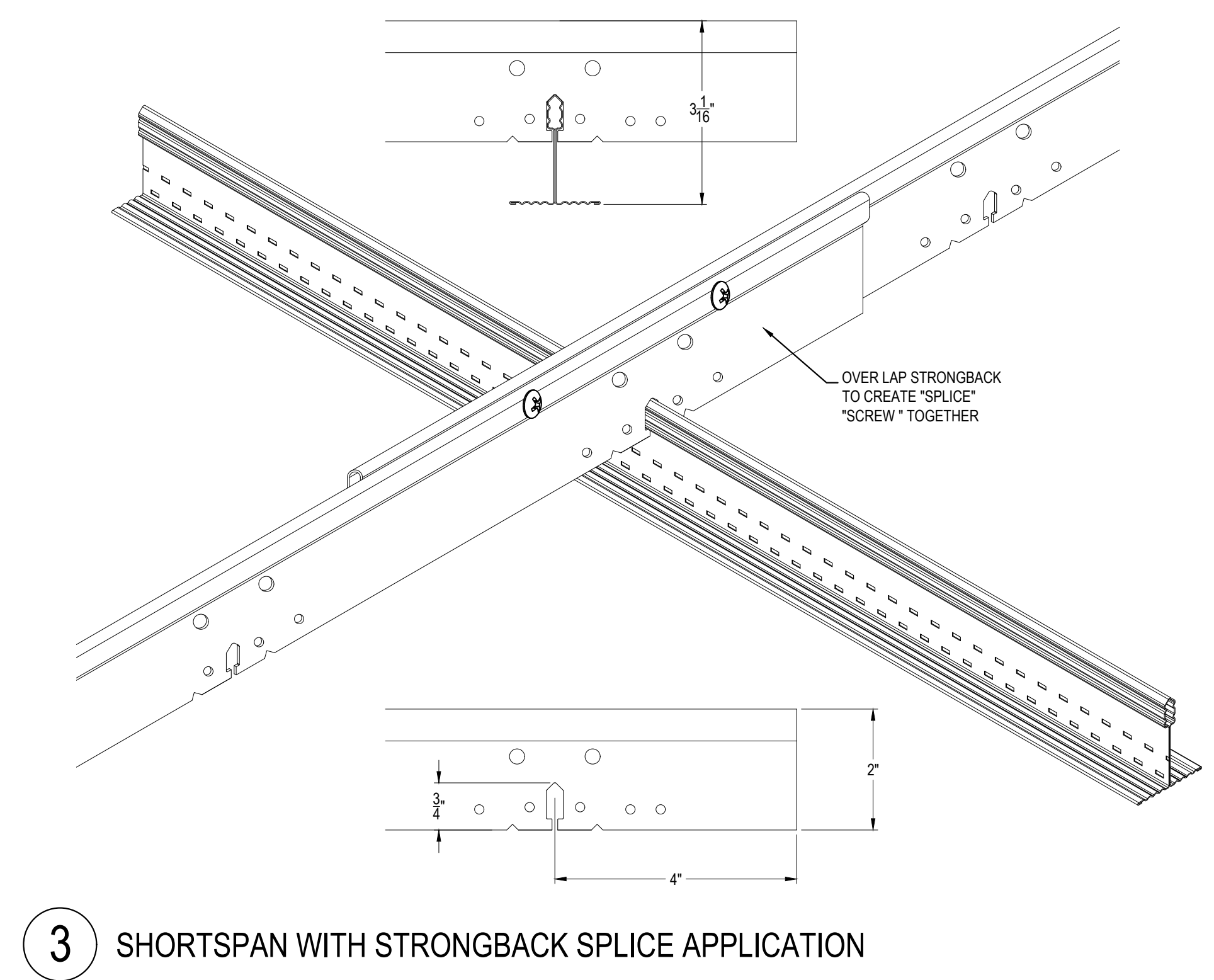

3 SHORTSPAN WITH STRONGBACK SPLICE APPLICATION

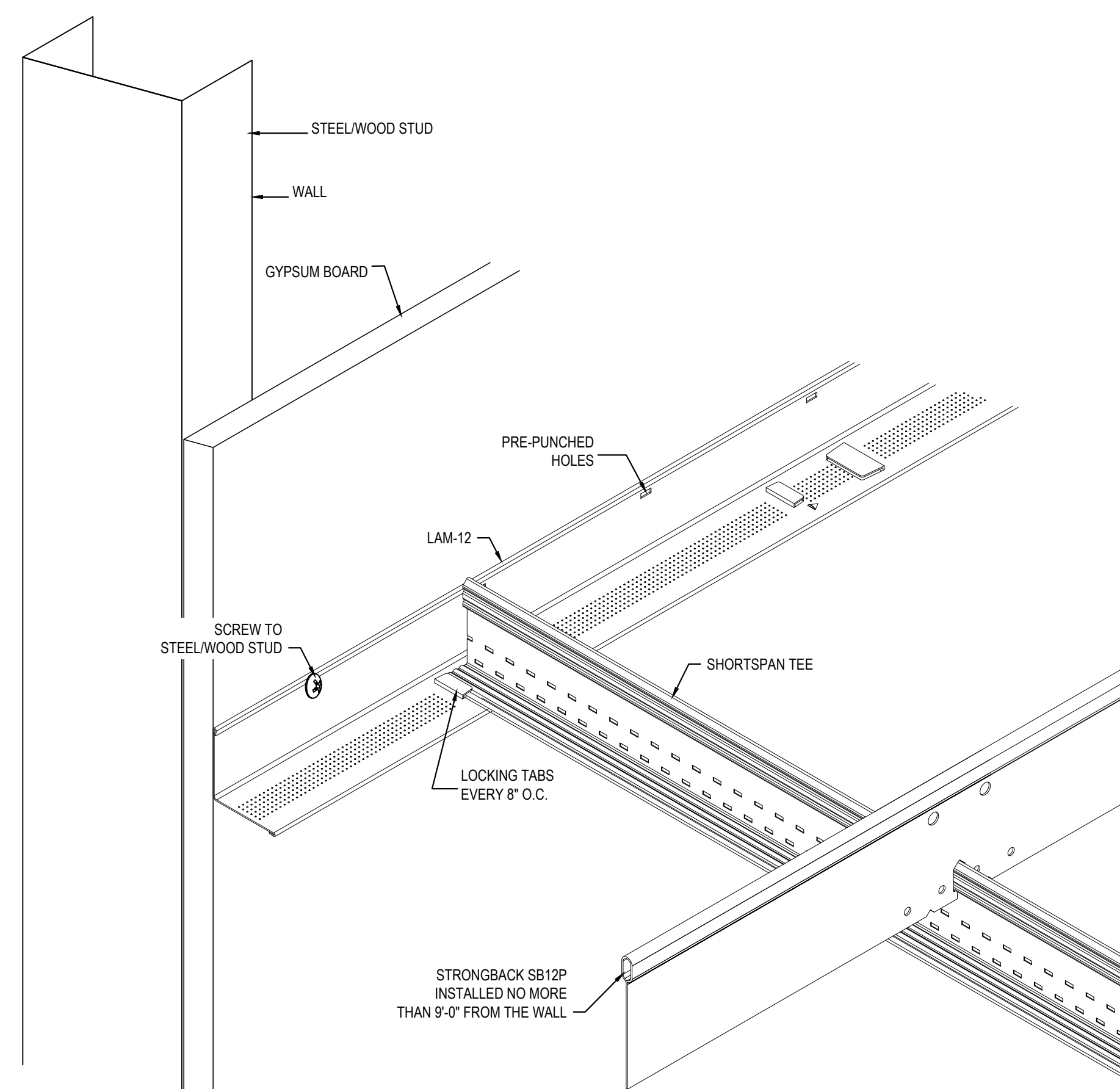

4 SHORTSPAN AT WALL

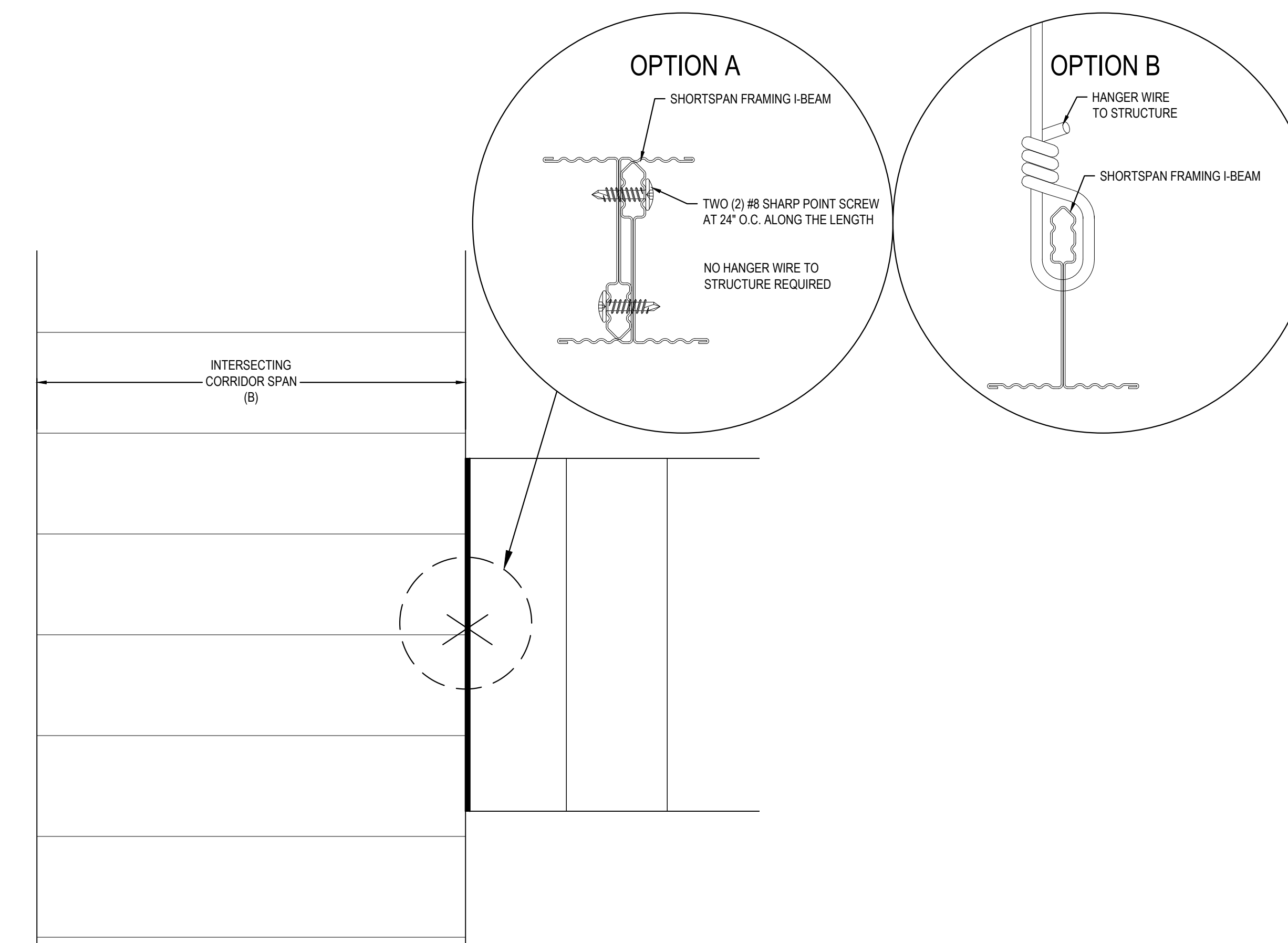

5 SHORTSPAN INTERSECTION CORRIDORS WITH I-BEAM GIRDER

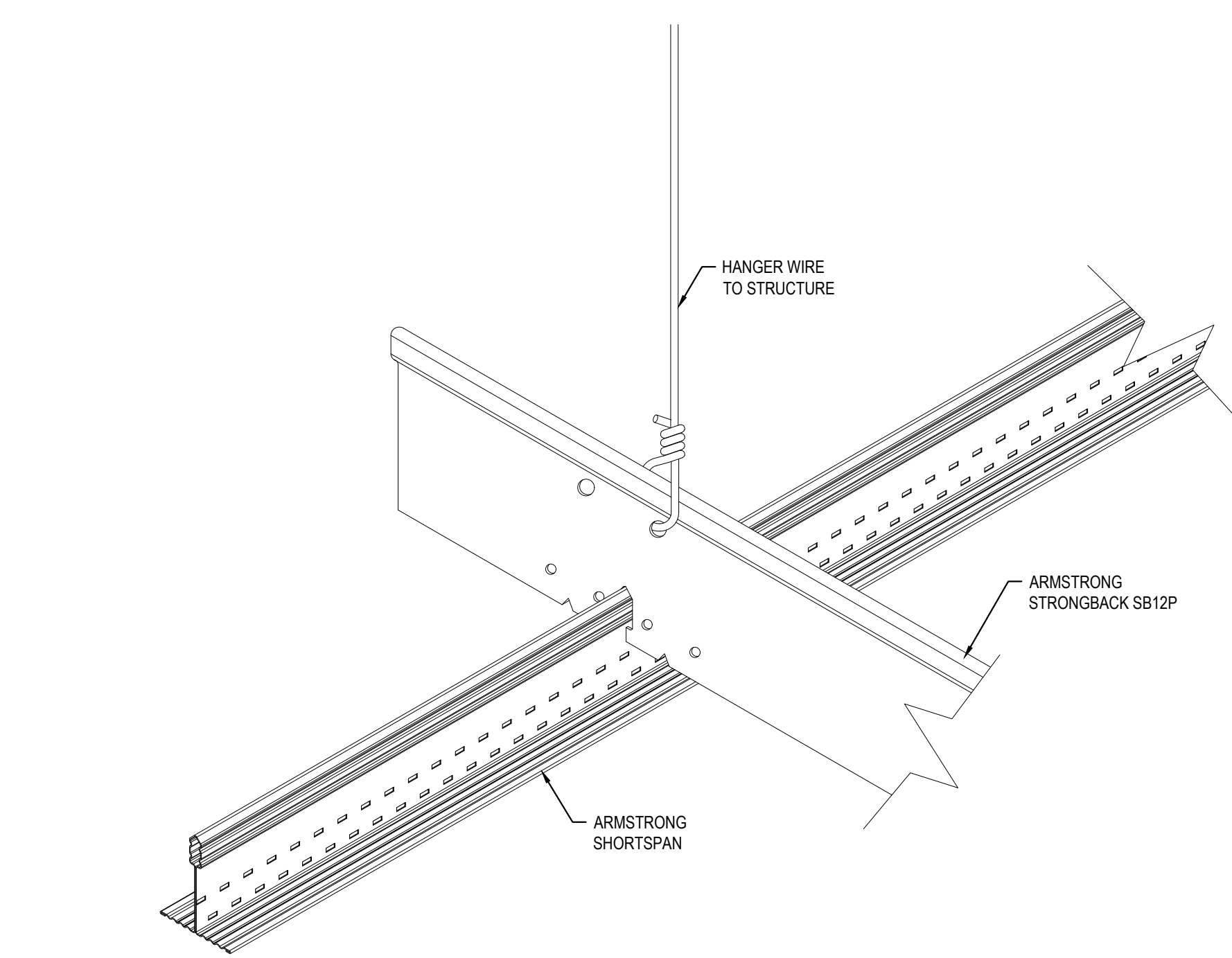

6 SHORTSPAN WITH STRONGBACK APPLICATION

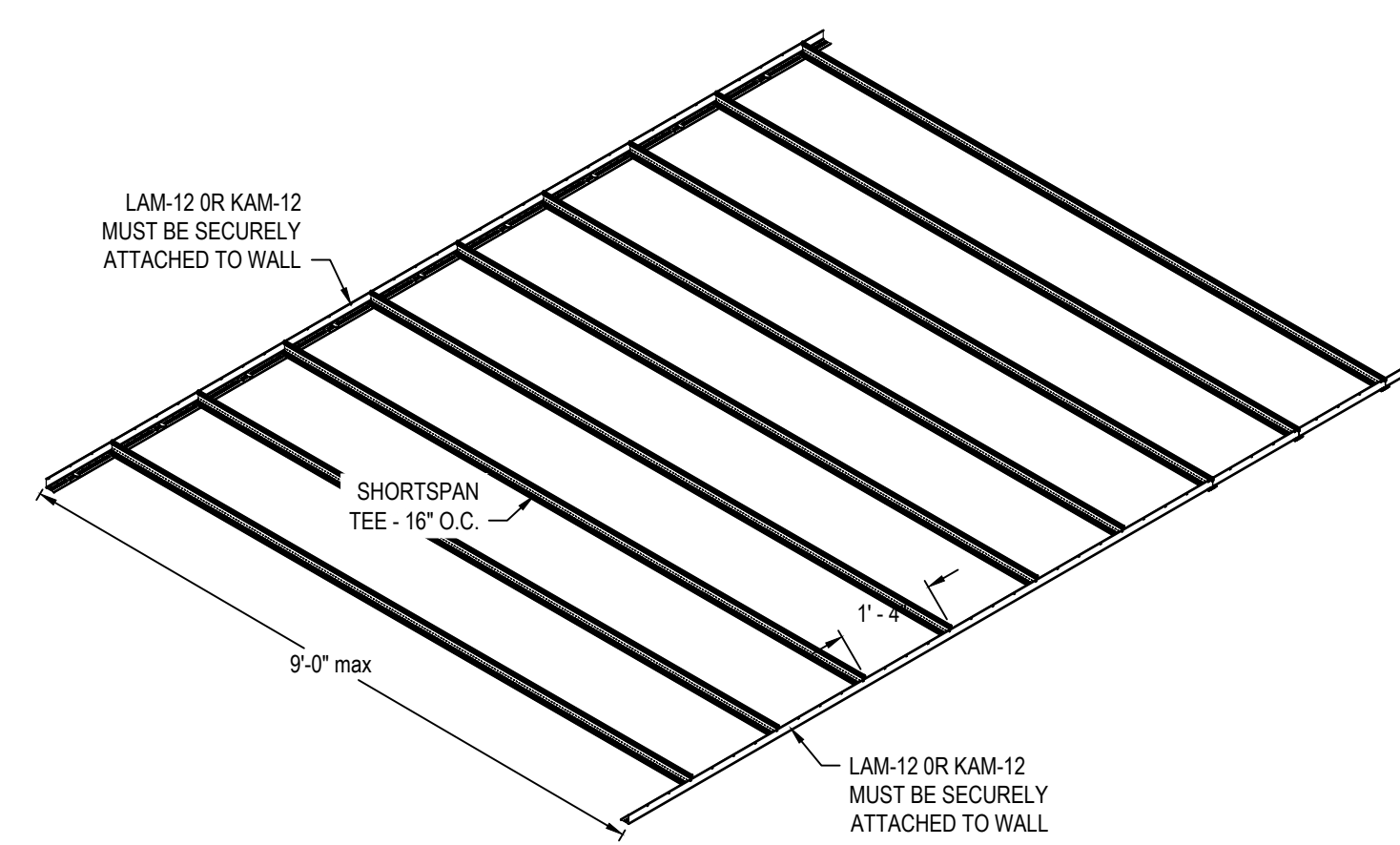

7 SHORTSPAN LAYOUT WITH 9'-0" SPAN

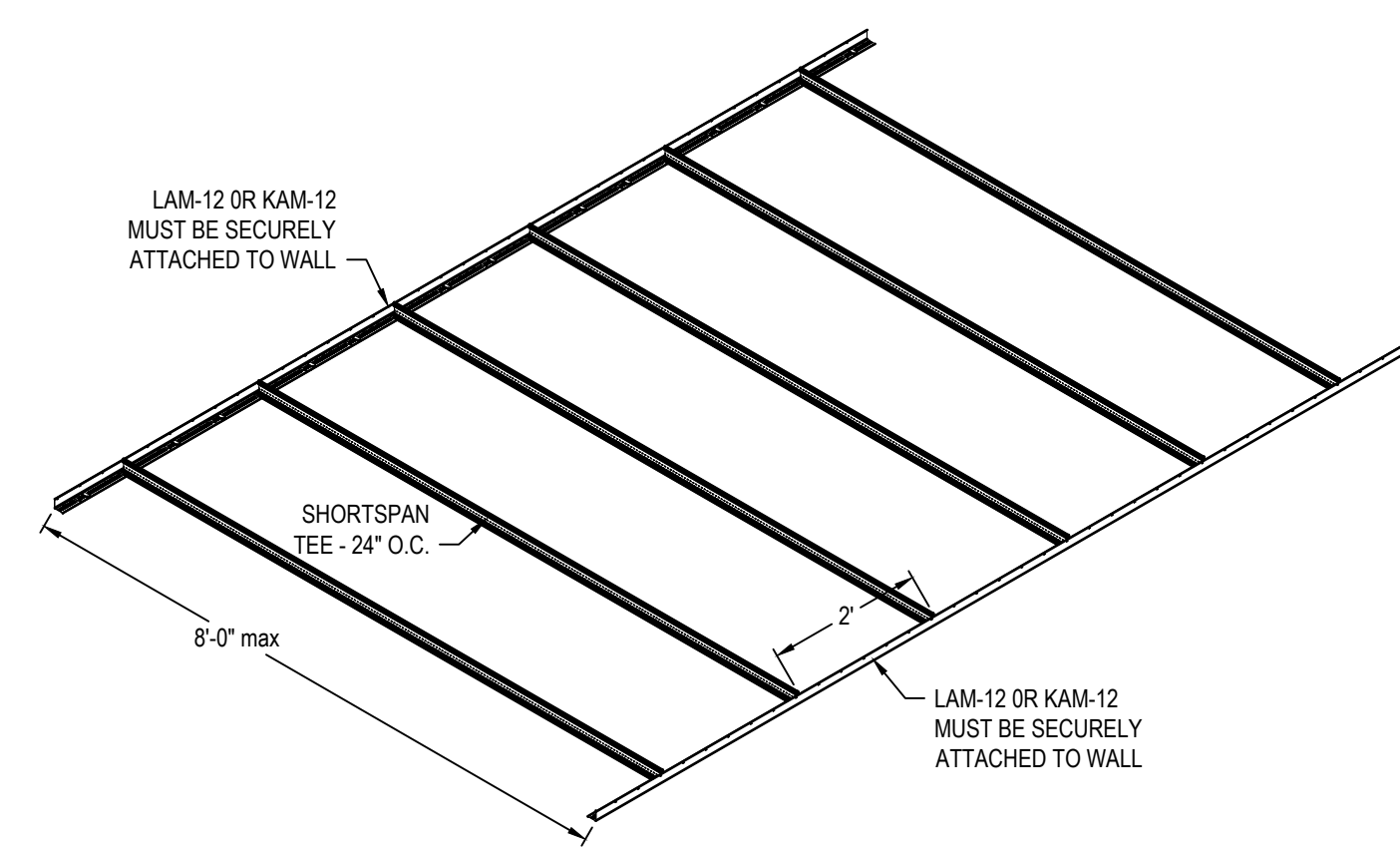

8 SHORTSPAN LAYOUT WITH 8'-0" SPAN

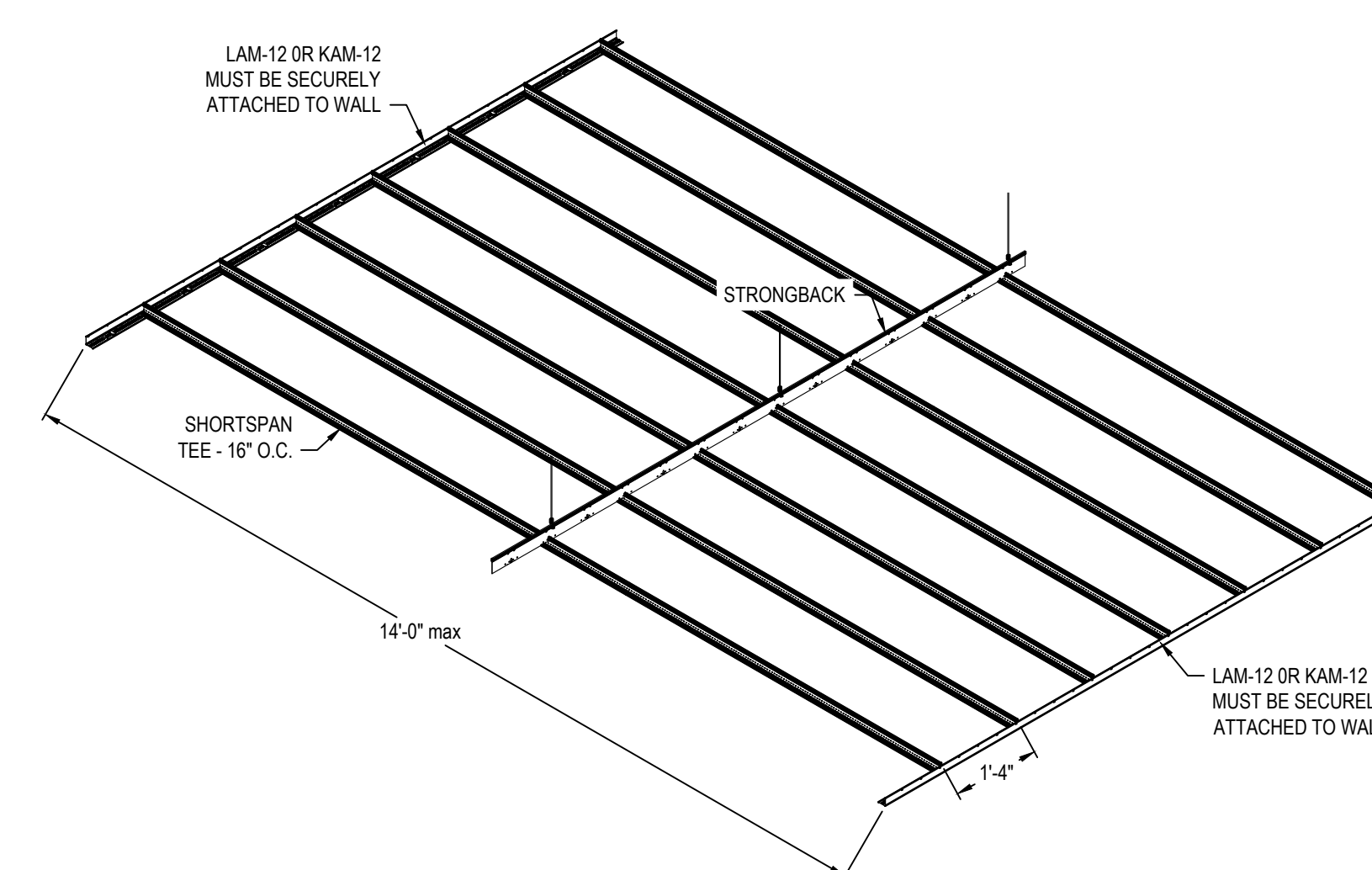

9 SHORTSPAN LAYOUT WITH 14' SPAN 16" O.C.

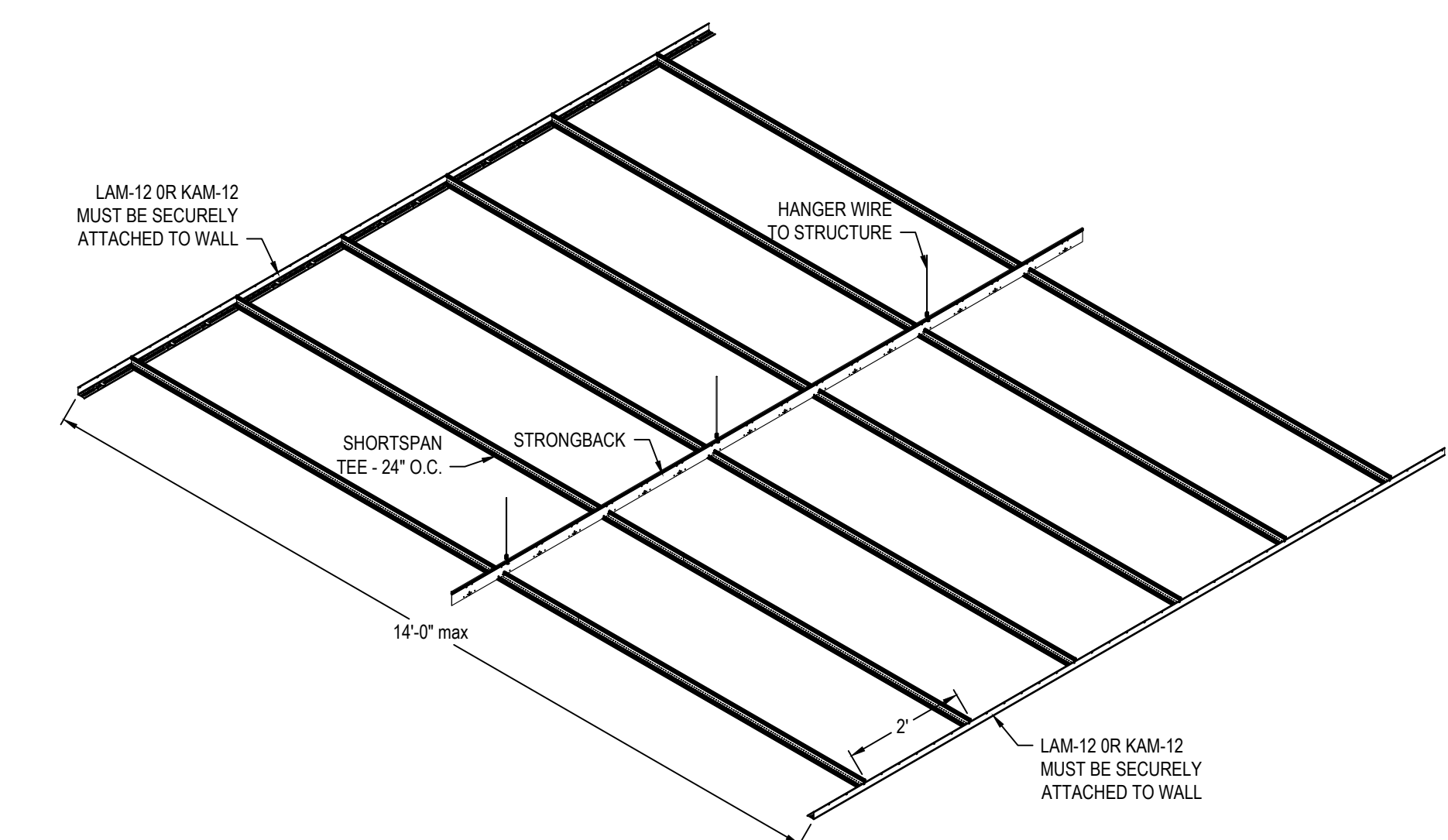

10 SHORTSPAN LAYOUT WITH 14' SPAN 24" O.C.

NOTE: ELIMINATES HANGER WIRES FOR SPANS UP TO 9'-0"

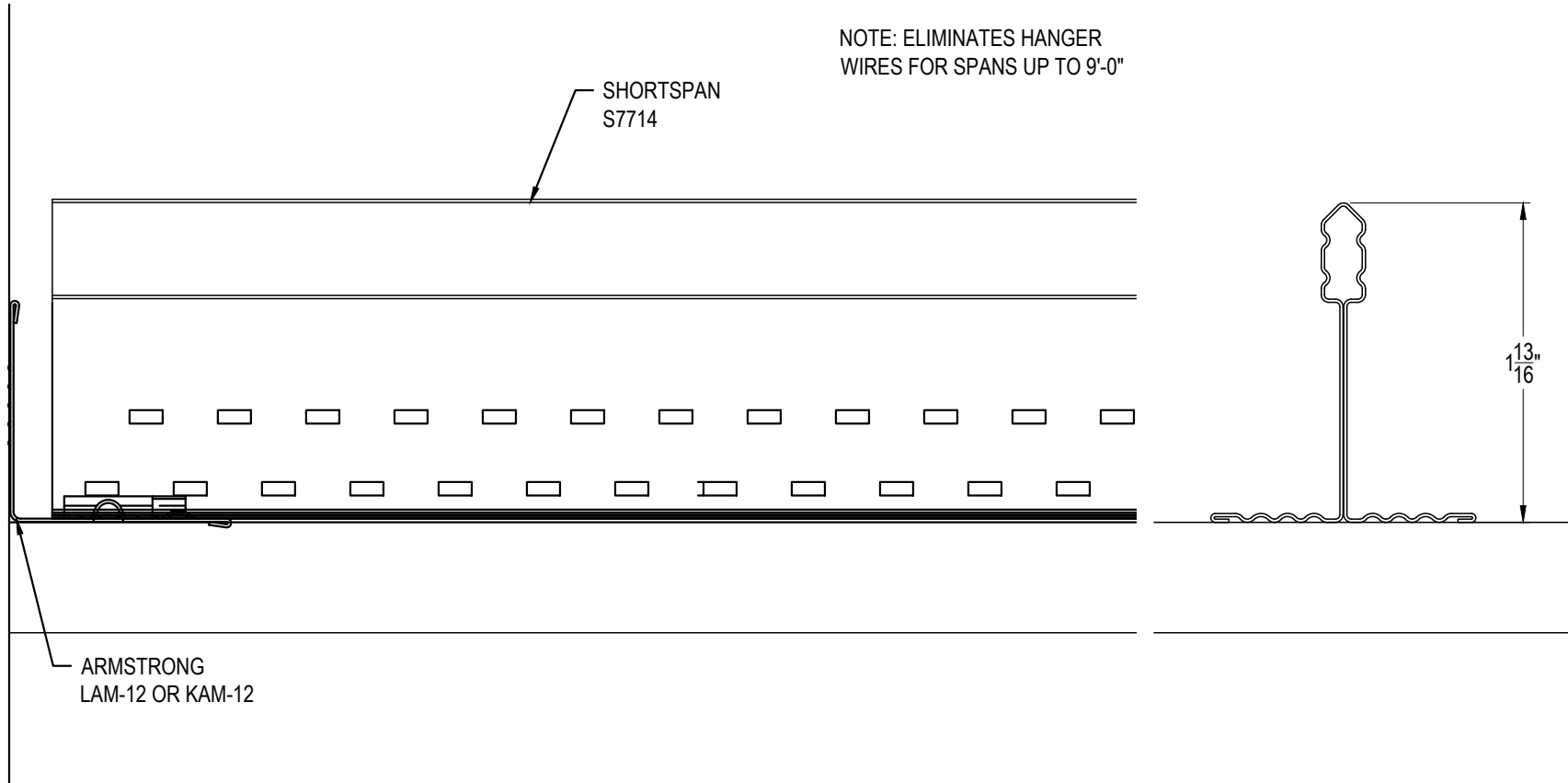

1 SHORTSPAN AT PERIMETER WALL

SHORTSPAN

These drawings show typical conditions in which the Armstrong product depicted is installed. They are not a substitute for an architect's or engineer's plan and do not reflect the unique requirements of local building codes, laws, statutes, ordinances, rules and regulations (Legal Requirements) that may be applicable for a particular installation.

Armstrong does not warrant, and assumes no liability for the accuracy or completeness of the drawings for a particular installation or their fitness for a particular purpose. The user is advised to consult with a duly licensed architect or engineer in the particular locale of the installation to assure compliance with all Legal Requirements.

Armstrong is not licensed to provide professional architecture or engineering design services.

PROJECT NAME: SHORTSPAN MASTER SHEET			
SHORTSPAN AT PERIMETER WALL			
DWG. NO. A-01-MS-02		REV: .	DATE: .
DATE: 4/12/24	SCALE: .	DESC.: .	
DRAWN BY: MAP	CHK BY: .		



CEILING & WALL SOLUTIONS * ARMSTRONG WORLD INDUSTRIES, INC. * Lancaster, PA * Phone: 877-ARMSTRONG



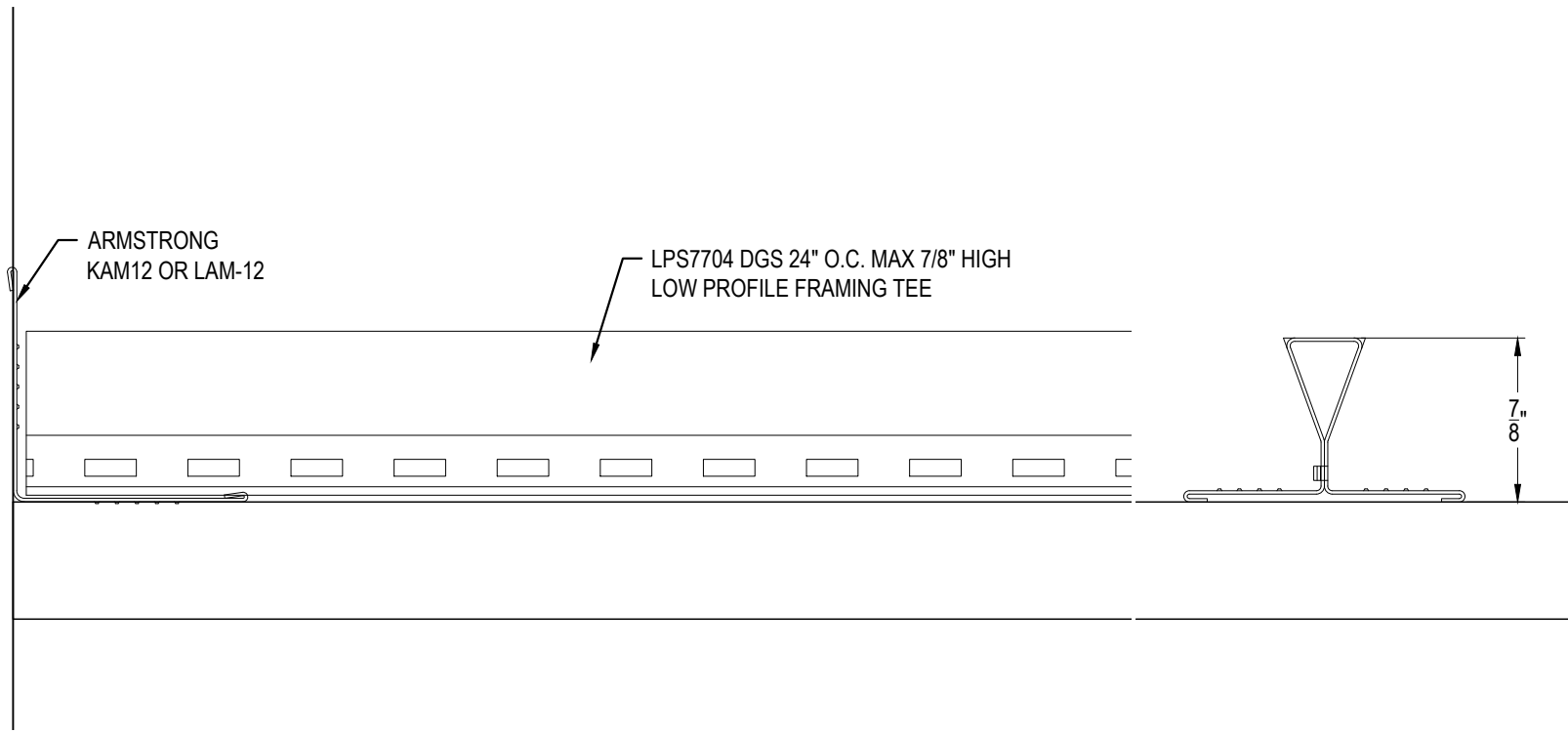

2 SHORTSPAN LOW PROFILE AT PERIMETER WALL LOW PROFILE SHORTSPAN

These drawings show typical conditions in which the Armstrong product depicted is installed. They are not a substitute for an architect's or engineer's plan and do not reflect the unique requirements of local building codes, laws, statutes, ordinances, rules and regulations (Legal Requirements) that may be applicable for a particular installation.

Armstrong does not warrant, and assumes no liability for the accuracy or completeness of the drawings for a particular installation or their fitness for a particular purpose. The user is advised to consult with a duly licensed architect or engineer in the particular locale of the installation to assure compliance with all Legal Requirements.

Armstrong is not licensed to provide professional architecture or engineering design services.

PROJECT NAME: SHORTSPAN MASTER SHEET			
SHORTSPAN LOW PROFILE AT PERIMETER WALL			
DWG. NO. A-01-MS-03		REV: .	DATE: .
DATE: 4/12/24	SCALE: .	DESC.: .	
DRAWN BY: MAP	CHK BY: .		



CEILING & WALL SOLUTIONS * ARMSTRONG WORLD INDUSTRIES, INC. * Lancaster, PA * Phone: 877-ARMSTRONG



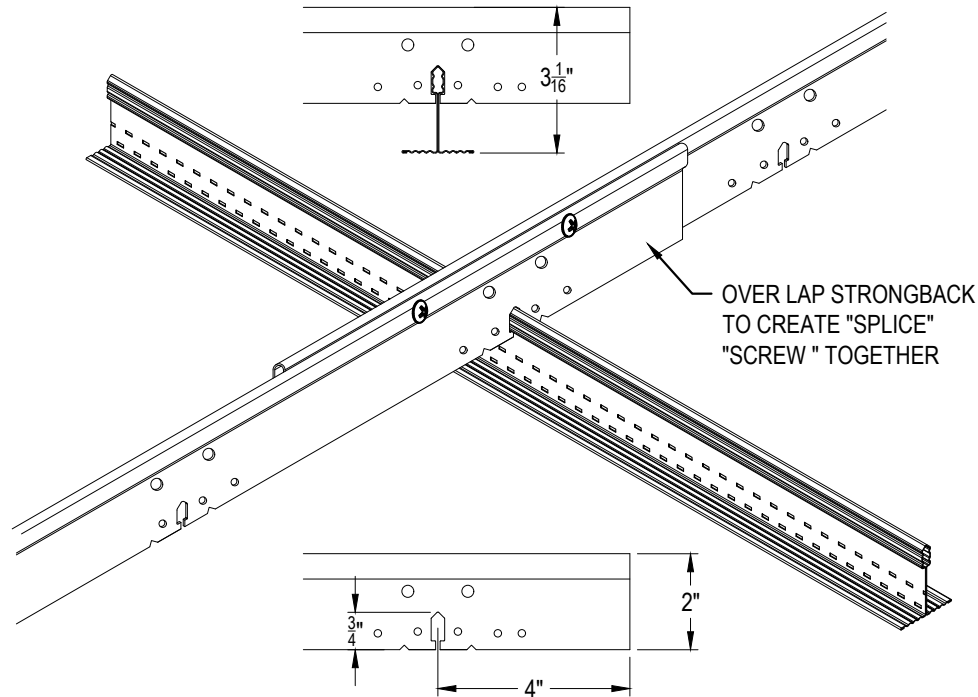

3

SHORTSPAN WITH STRONGBACK SPLICE APPLICATION

These drawings show typical conditions in which the Armstrong product depicted is installed. They are not a substitute for an architect's or engineer's plan and do not reflect the unique requirements of local building codes, laws, statutes, ordinances, rules and regulations (Legal Requirements) that may be applicable for a particular installation.

Armstrong does not warrant, and assumes no liability for the accuracy or completeness of the drawings for a particular installation or their fitness for a particular purpose. The user is advised to consult with a duly licensed architect or engineer in the particular locale of the installation to assure compliance with all Legal Requirements.

Armstrong is not licensed to provide professional architecture or engineering design services.

PROJECT NAME: SHORTSPAN MASTER SHEET			
SHORTSPAN WITH STRONGBACK SPLICE APPLICATION			
DWG. NO. A-01-MS-04		REV: .	DATE: .
DATE: 4/12/24	SCALE: .	DESC.: .	
DRAWN BY: MAP	CHK BY: .		



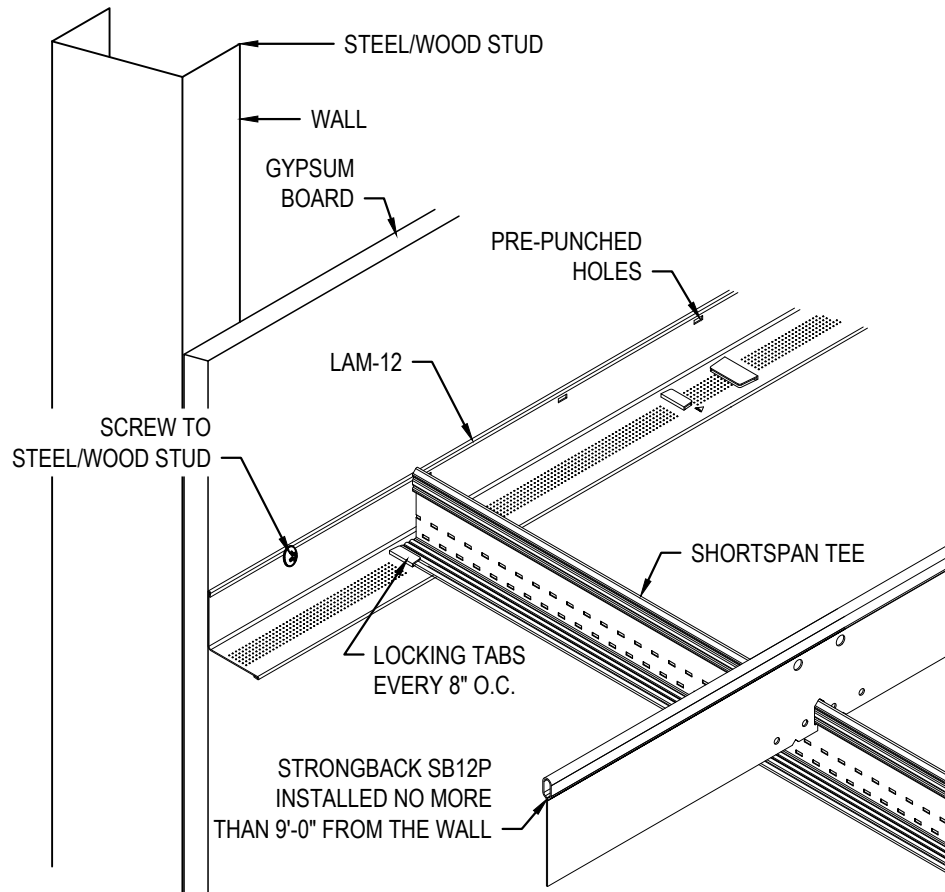

4 SHORTSPAN AT WALL

These drawings show typical conditions in which the Armstrong product depicted is installed. They are not a substitute for an architect's or engineer's plan and do not reflect the unique requirements of local building codes, laws, statutes, ordinances, rules and regulations (Legal Requirements) that may be applicable for a particular installation.

Armstrong does not warrant, and assumes no liability for the accuracy or completeness of the drawings for a particular installation or their fitness for a particular purpose. The user is advised to consult with a duly licensed architect or engineer in the particular locale of the installation to assure compliance with all Legal Requirements.

Armstrong is not licensed to provide professional architecture or engineering design services.

PROJECT NAME:		SHORTSPAN MASTER SHEET SHORTSPAN AT WALL	
DWG. NO. A-01-MS-05		REV: .	DATE: .
DATE: 4/12/24	SCALE: .	DESC.: .	
DRAWN BY: MAP	CHK BY: .		

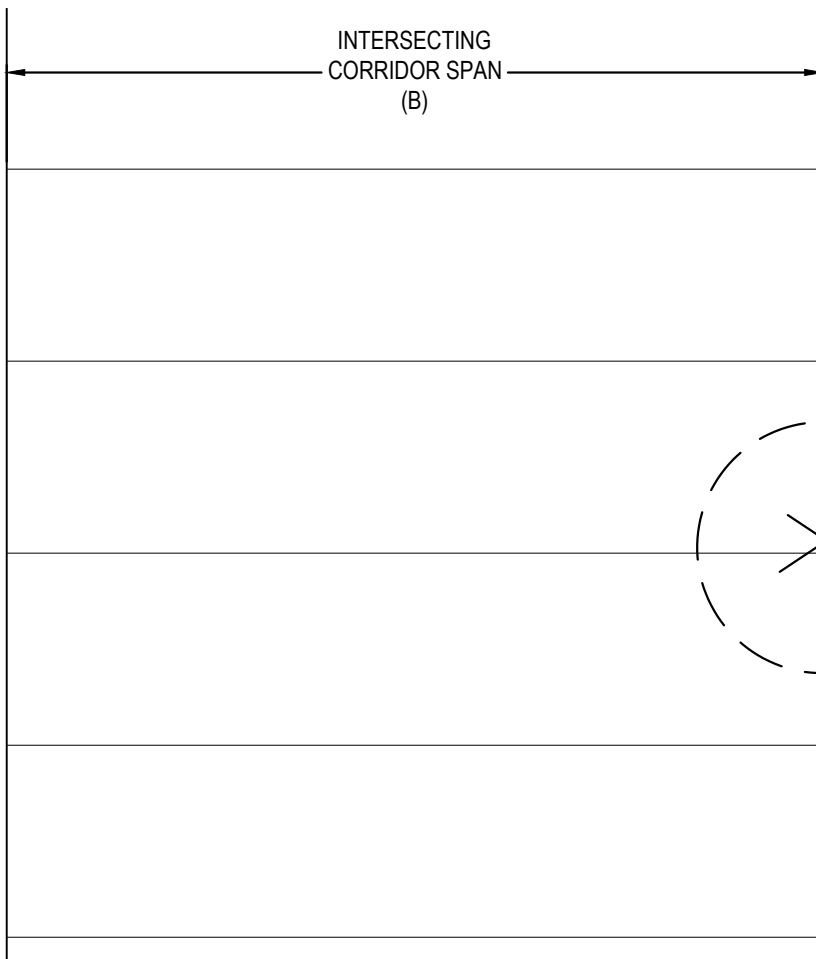

OPTION A

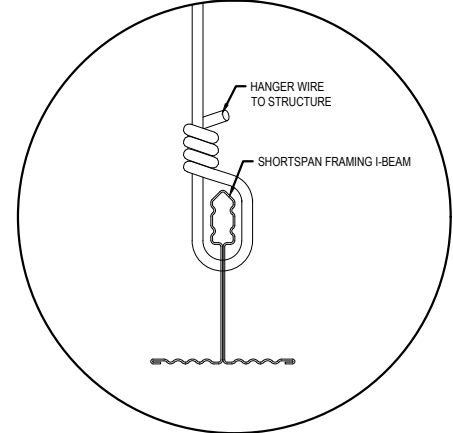
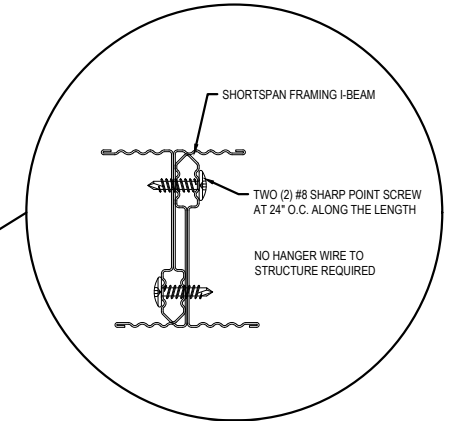

OPTION B

5

SHORTSPAN INTERSECTION CORRIDORS WITH I-BEAM GIRDER

These drawings show typical conditions in which the Armstrong product depicted is installed. They are not a substitute for an architect's or engineer's plan and do not reflect the unique requirements of local building codes, laws, statutes, ordinances, rules and regulations (Legal Requirements) that may be applicable for a particular installation.

Armstrong does not warrant, and assumes no liability for the accuracy or completeness of the drawings for a particular installation or their fitness for a particular purpose. The user is advised to consult with a duly licensed architect or engineer in the particular locale of the installation to assure compliance with all Legal Requirements.

Armstrong is not licensed to provide professional architecture or engineering design services.

PROJECT NAME: **SHORTSPAN MASTER SHEET**
SHORTSPAN INTERSECTION CORRIDORS WITH I-BEAM GIRDER

DWG. NO. A-01-MS-06		REV: .	DATE: .
DATE: 4/12/24	SCALE: .	DESC.: .	
DRAWN BY: MAP	CHK BY: .		

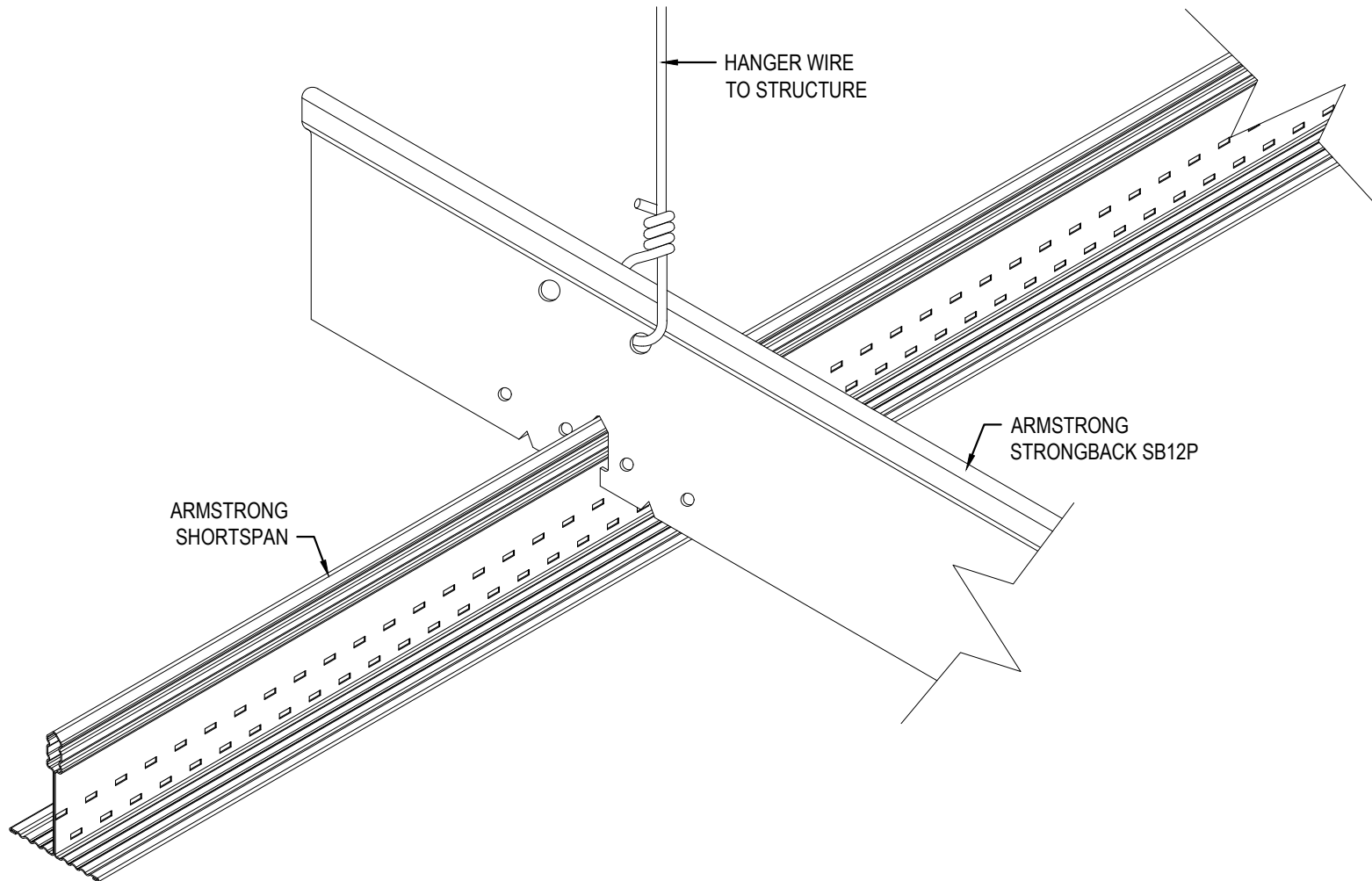

6

SHORTSPAN WITH STRONGBACK APPLICATION

These drawings show typical conditions in which the Armstrong product depicted is installed. They are not a substitute for an architect's or engineer's plan and do not reflect the unique requirements of local building codes, laws, statutes, ordinances, rules and regulations (Legal Requirements) that may be applicable for a particular installation.

Armstrong does not warrant, and assumes no liability for the accuracy or completeness of the drawings for a particular installation or their fitness for a particular purpose. The user is advised to consult with a duly licensed architect or engineer in the particular locale of the installation to assure compliance with all Legal Requirements.

Armstrong is not licensed to provide professional architecture or engineering design services.

PROJECT NAME: SHORTSPAN MASTER SHEET SHORTSPAN WITH STRONGBACK APPLICATION			
DWG. NO. A-01-MS-07		REV: .	DATE: .
DATE: 4/12/24	SCALE: .	DESC.: .	
DRAWN BY: MAP	CHK BY: .		

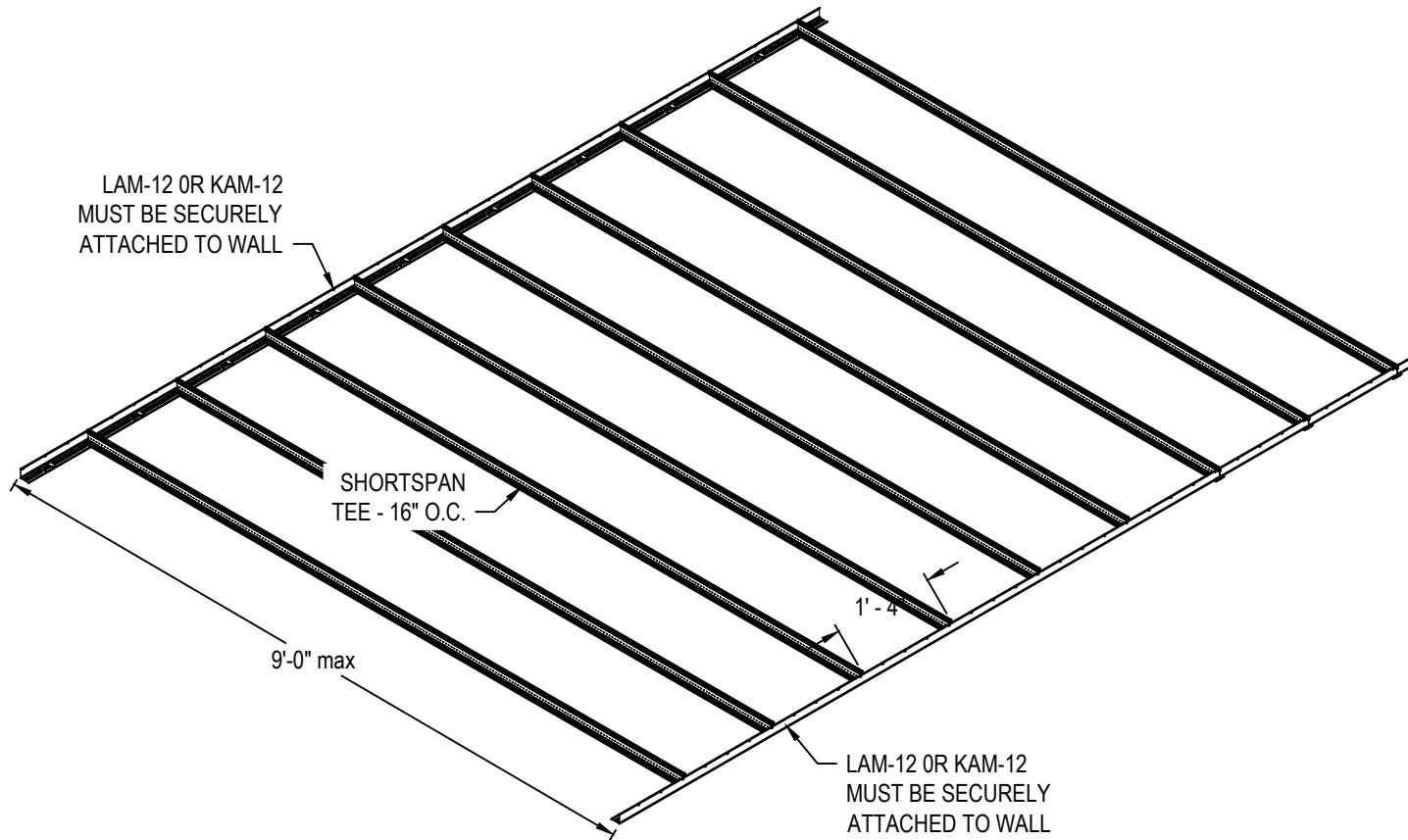

7 SHORTSPAN LAYOUT WITH 9'-0" SPAN

These drawings show typical conditions in which the Armstrong product depicted is installed. They are not a substitute for an architect's or engineer's plan and do not reflect the unique requirements of local building codes, laws, statutes, ordinances, rules and regulations (Legal Requirements) that may be applicable for a particular installation.

Armstrong does not warrant, and assumes no liability for the accuracy or completeness of the drawings for a particular installation or their fitness for a particular purpose. The user is advised to consult with a duly licensed architect or engineer in the particular locale of the installation to assure compliance with all Legal Requirements.

Armstrong is not licensed to provide professional architecture or engineering design services.

PROJECT NAME: SHORTSPAN MASTER SHEET SHORTSPAN LAYOUT WITH 9'-0" SPAN			
DWG. NO. A-01-MS-08		REV: .	DATE: .
DATE: 4/12/24	SCALE: .	DESC.: .	
DRAWN BY: MAP	CHK BY: .		

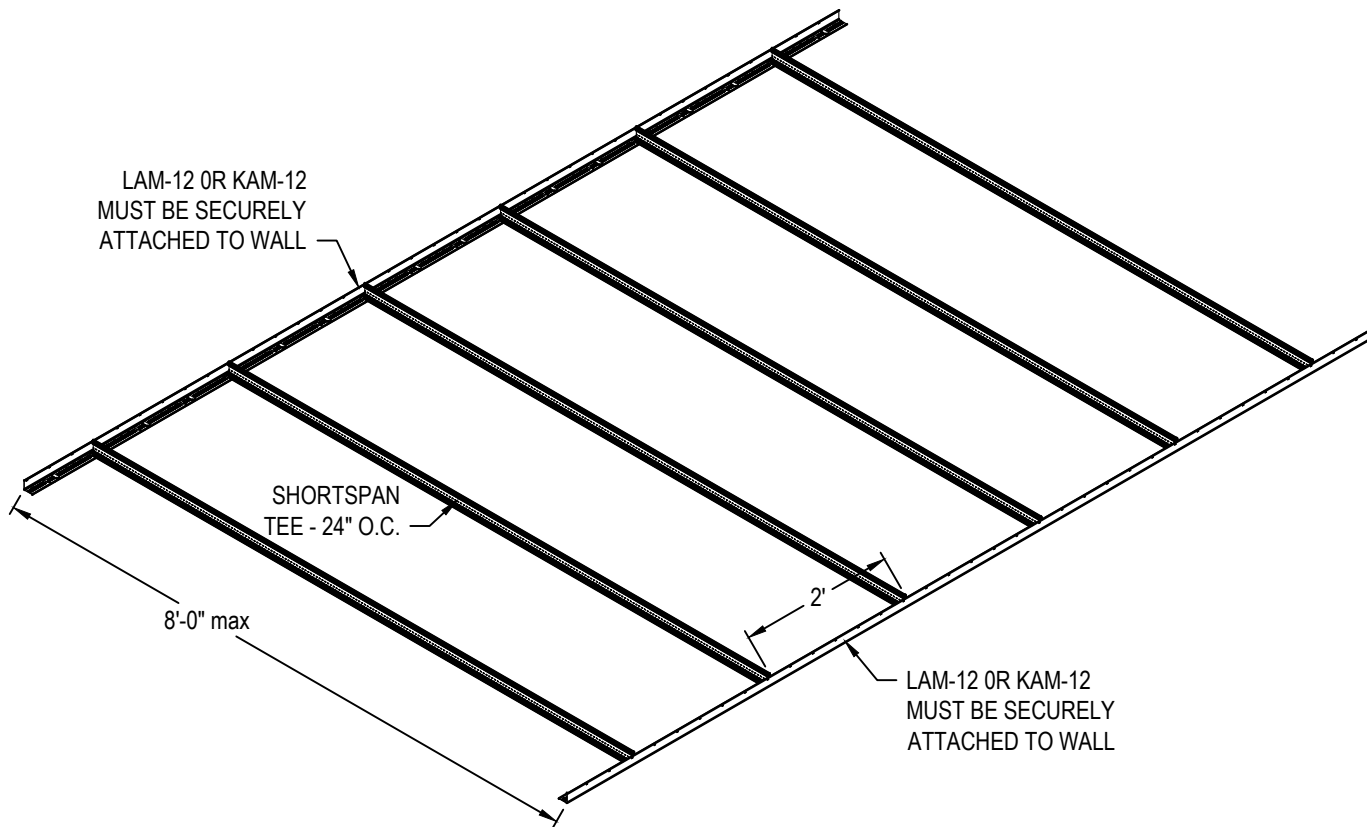

8

SHORTSPAN LAYOUT WITH 8'-0" SPAN

These drawings show typical conditions in which the Armstrong product depicted is installed. They are not a substitute for an architect's or engineer's plan and do not reflect the unique requirements of local building codes, laws, statutes, ordinances, rules and regulations (Legal Requirements) that may be applicable for a particular installation.

Armstrong does not warrant, and assumes no liability for the accuracy or completeness of the drawings for a particular installation or their fitness for a particular purpose. The user is advised to consult with a duly licensed architect or engineer in the particular locale of the installation to assure compliance with all Legal Requirements.

Armstrong is not licensed to provide professional architecture or engineering design services.

PROJECT NAME: SHORTSPAN MASTER SHEET SHORTSPAN LAYOUT WITH 8'-0" SPAN			
DWG. NO. A-01-MS-09		REV: .	DATE: .
DATE: 4/12/24	SCALE: .	DESC.: .	
DRAWN BY: MAP	CHK BY: .		

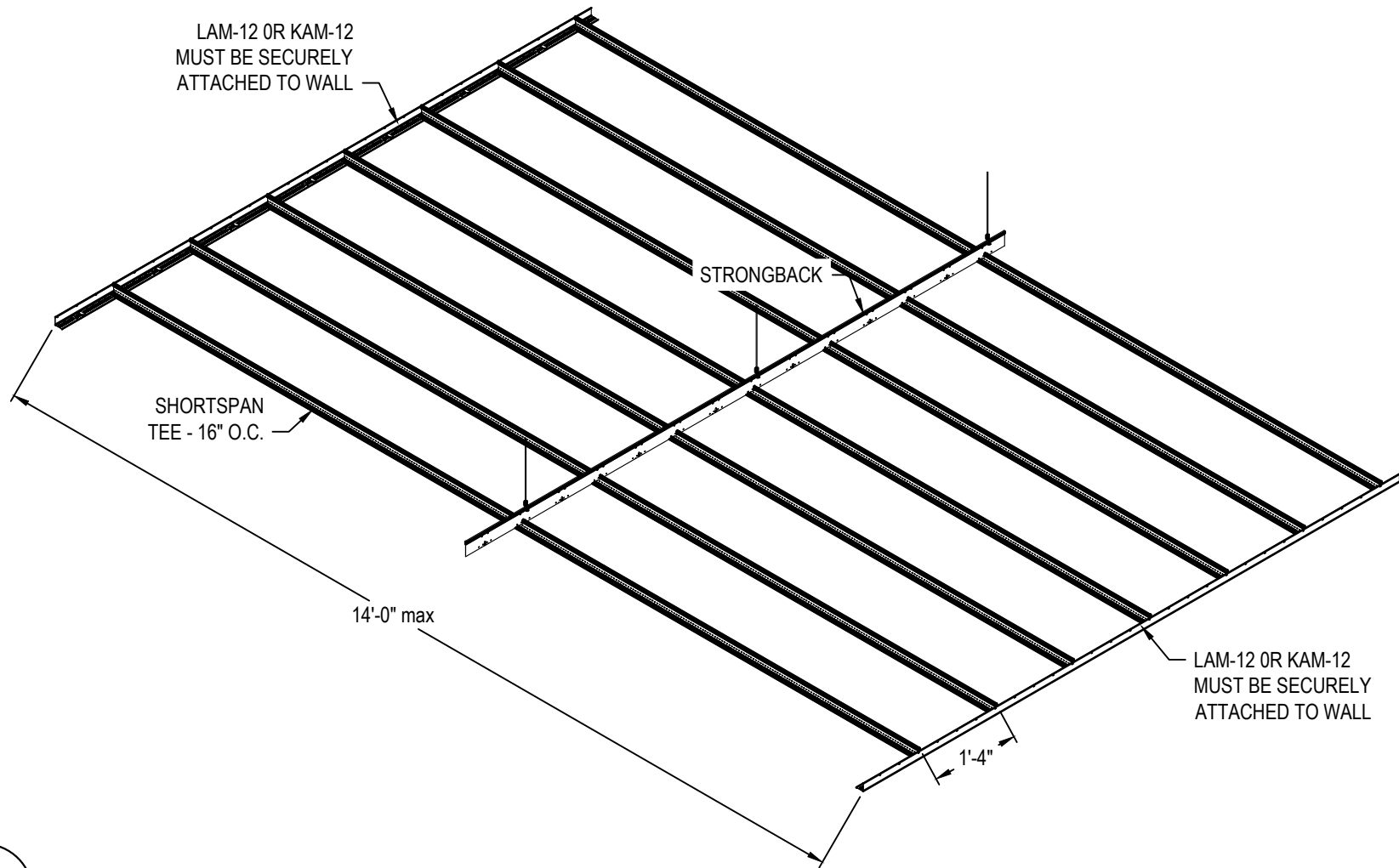

9

SHORTSPAN LAYOUT WITH 14' SPAN 16" O.C.

These drawings show typical conditions in which the Armstrong product depicted is installed. They are not a substitute for an architect's or engineer's plan and do not reflect the unique requirements of local building codes, laws, statutes, ordinances, rules and regulations (Legal Requirements) that may be applicable for a particular installation.

Armstrong does not warrant, and assumes no liability for the accuracy or completeness of the drawings for a particular installation or their fitness for a particular purpose. The user is advised to consult with a duly licensed architect or engineer in the particular locale of the installation to assure compliance with all Legal Requirements.

Armstrong is not licensed to provide professional architecture or engineering design services.

PROJECT NAME: SHORTSPAN MASTER SHEET			
SHORTSPAN LAYOUT WITH 14' SPAN 16" O.C.			
DWG. NO. A-01-MS-10		REV: .	DATE: .
DATE: 4/12/24	SCALE: .	DESC.: .	
DRAWN BY: MAP	CHK BY: .		

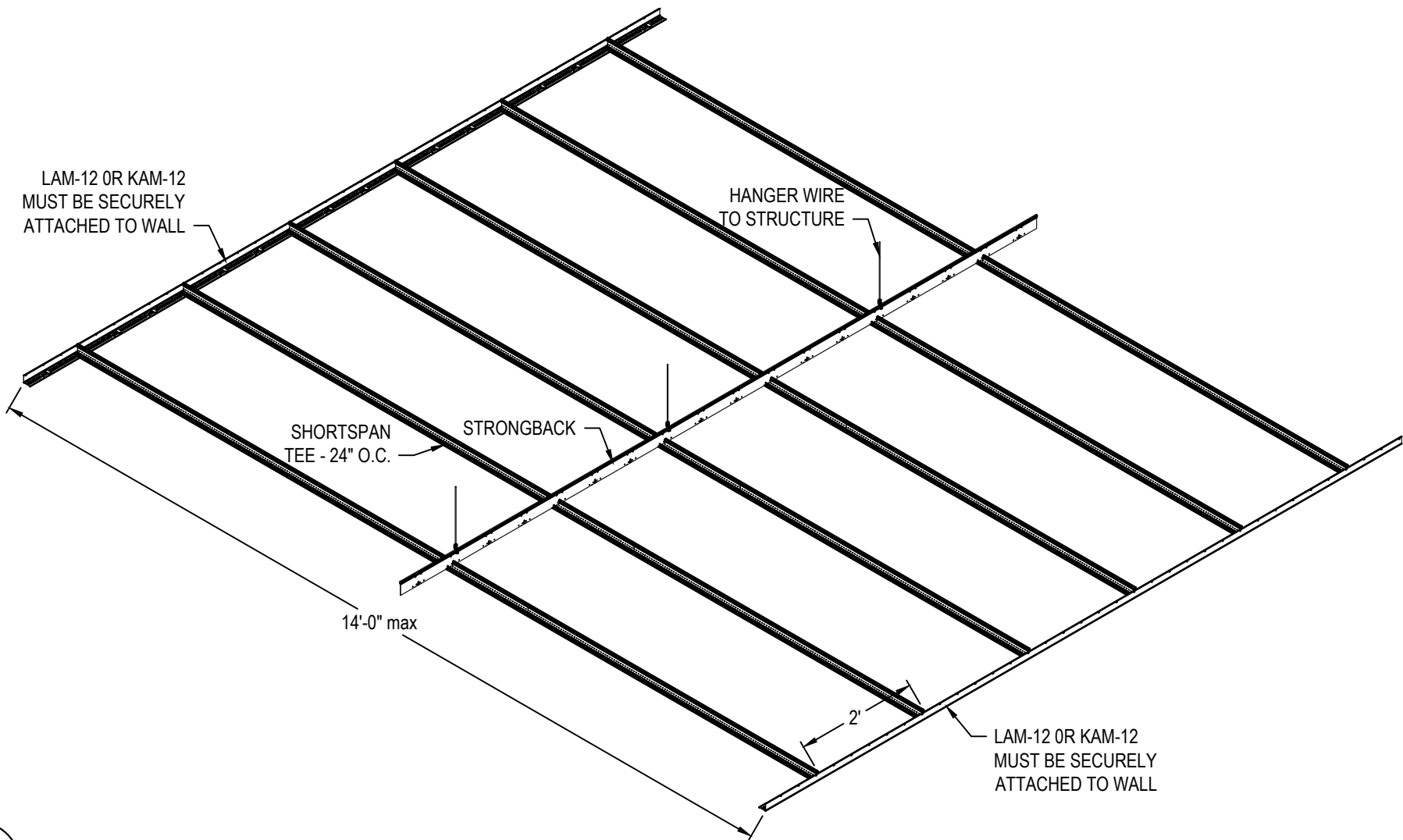

10 SHORTSPAN LAYOUT WITH 14' SPAN 24" O.C.

These drawings show typical conditions in which the Armstrong product depicted is installed. They are not a substitute for an architect's or engineer's plan and do not reflect the unique requirements of local building codes, laws, statutes, ordinances, rules and regulations (Legal Requirements) that may be applicable for a particular installation.

Armstrong does not warrant, and assumes no liability for the accuracy or completeness of the drawings for a particular installation or their fitness for a particular purpose. The user is advised to consult with a duly licensed architect or engineer in the particular locale of the installation to assure compliance with all Legal Requirements.

Armstrong is not licensed to provide professional architecture or engineering design services.

PROJECT NAME: SHORTSPAN MASTER SHEET SHORTSPAN LAYOUT WITH 14' SPAN 24" O.C.			
DWG. NO. A-01-MS-11		REV: .	DATE: .
DATE: 4/12/24	SCALE: .	DESC.: .	
DRAWN BY: MAP	CHK BY: .		