

1 TRADITION FRAMING COMPARISON

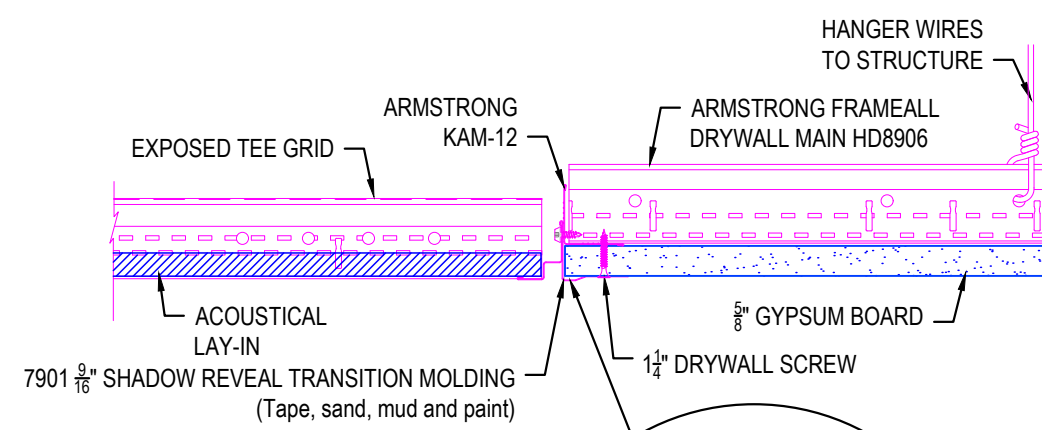

2 7901 TRANSITION MOLDING

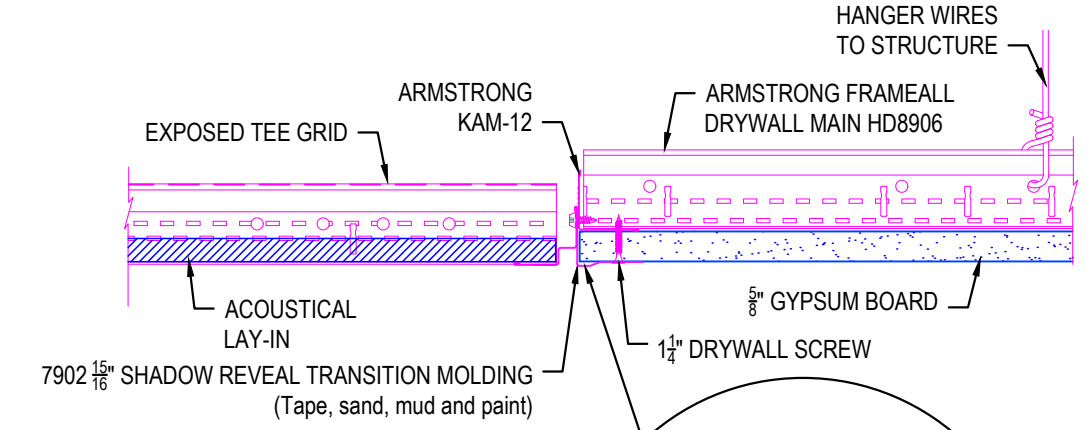
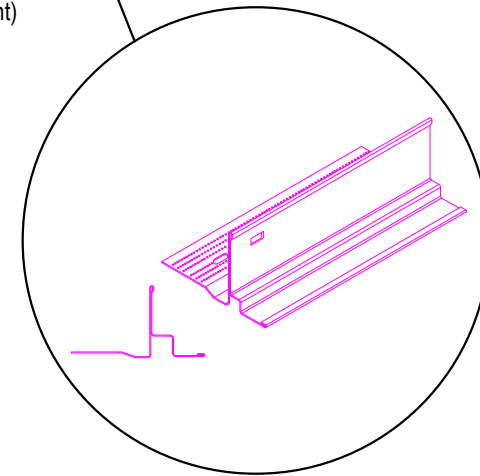

3 7902 TRANSITION MOLDING

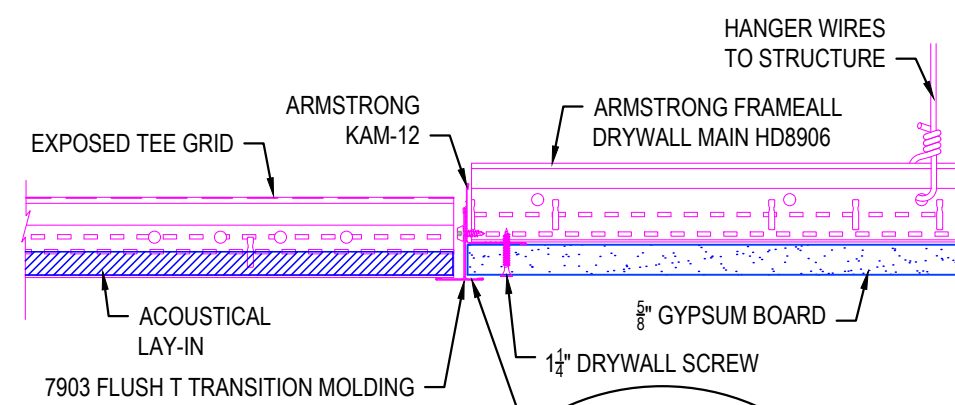
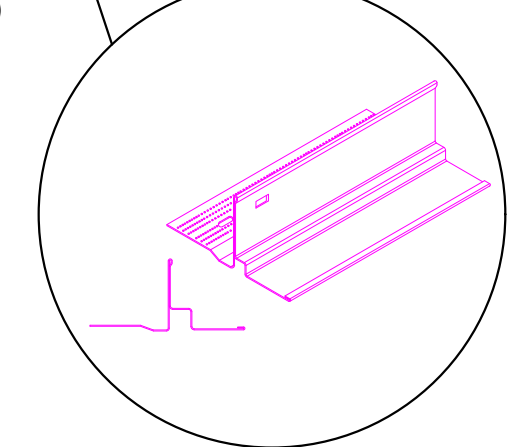

4 7903 TRANSITION MOLDING

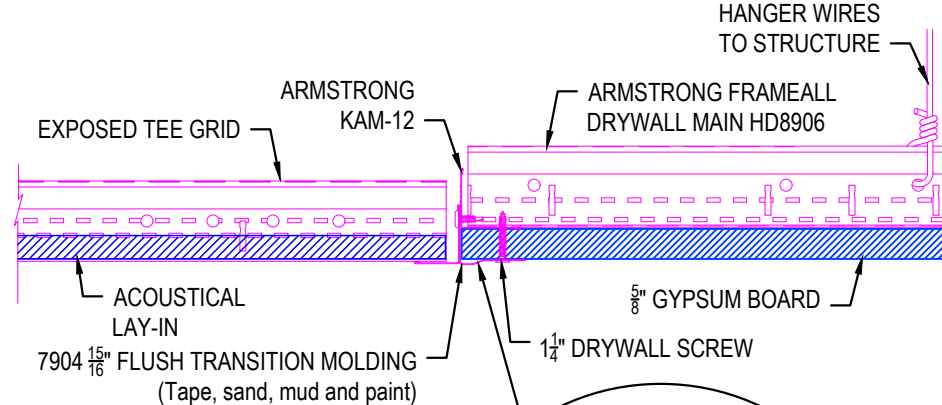
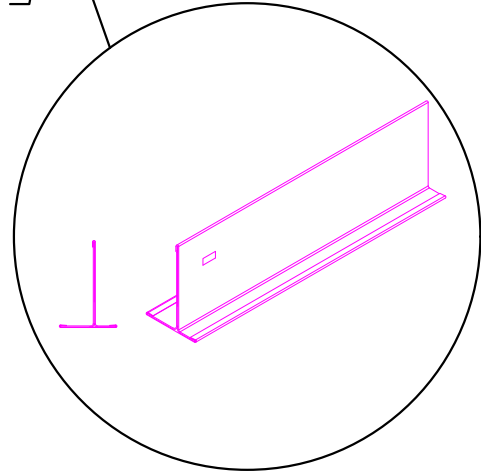

5 7904 TRANSITION MOLDING

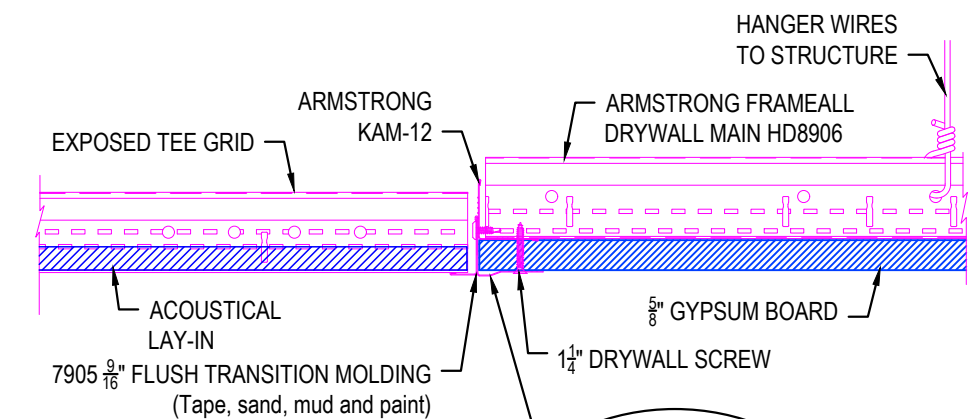
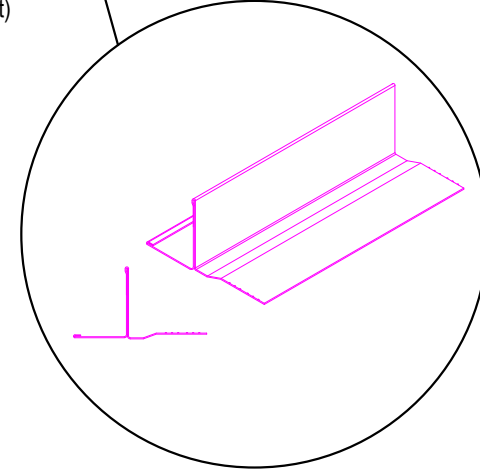

6 7905 TRANSITION MOLDING

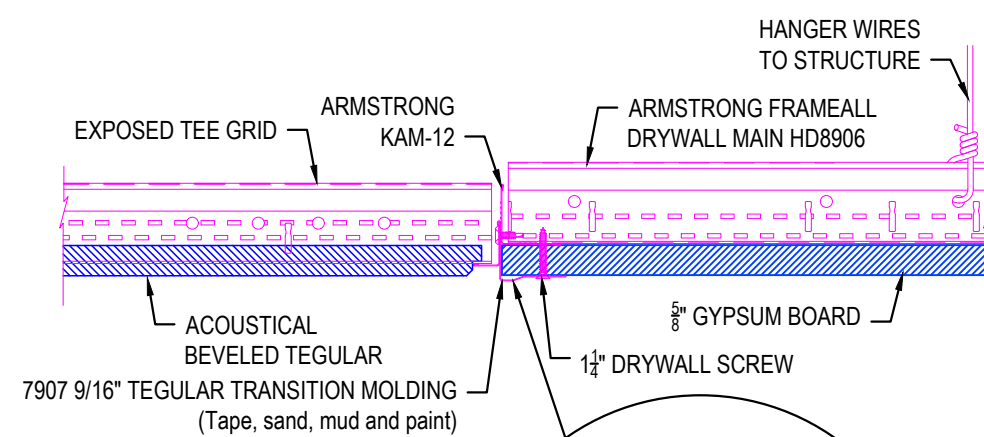
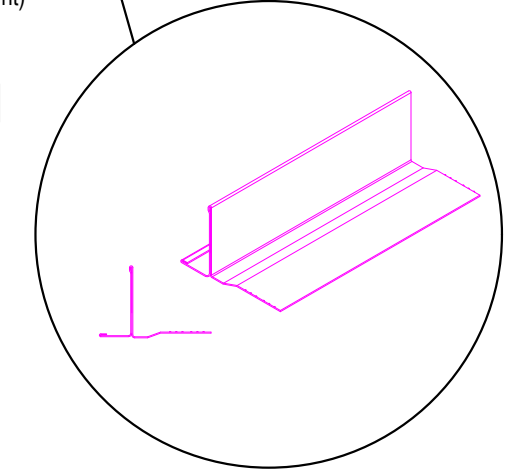

7 7907 TRANSITION MOLDING

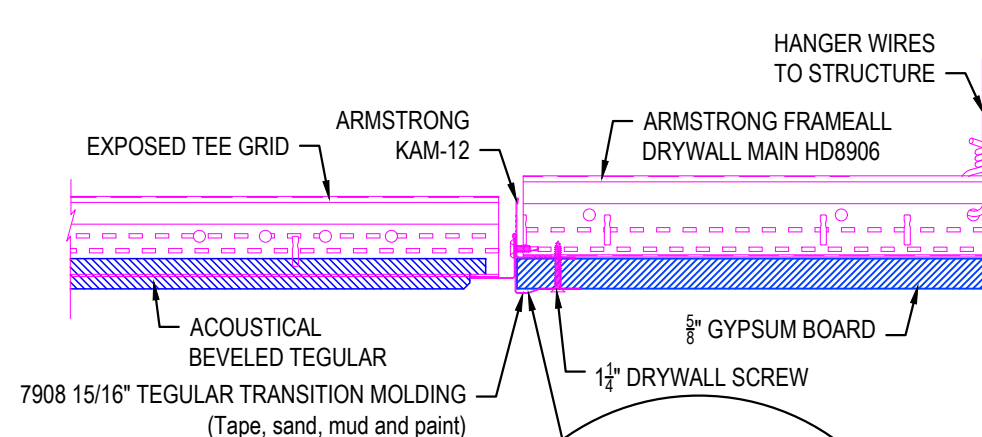
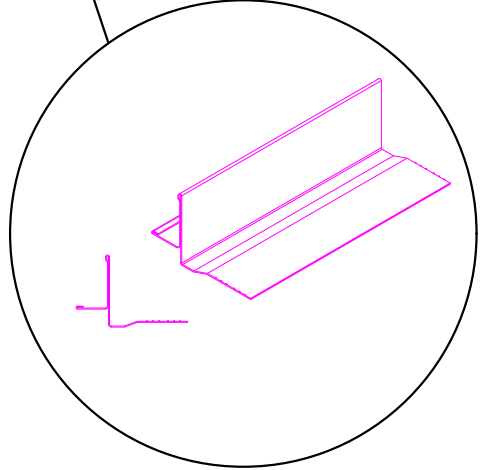

8 7908 TRANSITION MOLDING

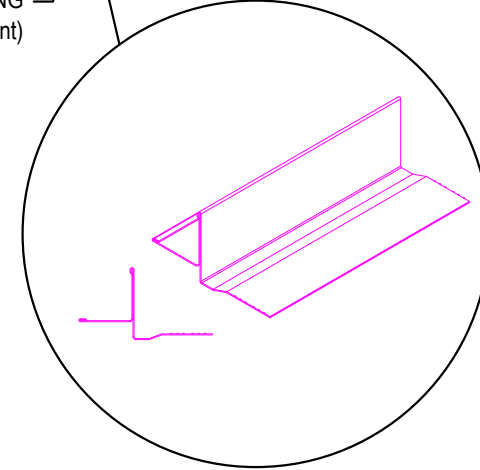

These drawings show typical conditions in which the Armstrong® product depicted is installed. They are not a substitute for an architect's or engineer's plan and do not reflect the unique requirements of local building codes, laws, statutes, ordinances, rules and regulations (Legal Requirements) that may be applicable for a particular installation. Armstrong Ceiling Solutions does not warrant, and assumes no liability for the accuracy or completeness of the drawings for a particular installation or their fitness for a particular purpose. The user is advised to consult with a duly licensed architect or engineer in the particular locale of the installation to assure compliance with all Legal Requirements. Armstrong is not licensed to provide professional architecture or engineering design services.

PROJECT NAME:		STEEL TRANSITION MOLDING MASTER SHEET	
DWG. NO. SHEET 1	REV: .	DATE: .	
DATE: 10/10/23	SCALE: .	DESC: .	
DRAWN BY: MAP	CHK BY: 3"=1'-0"		

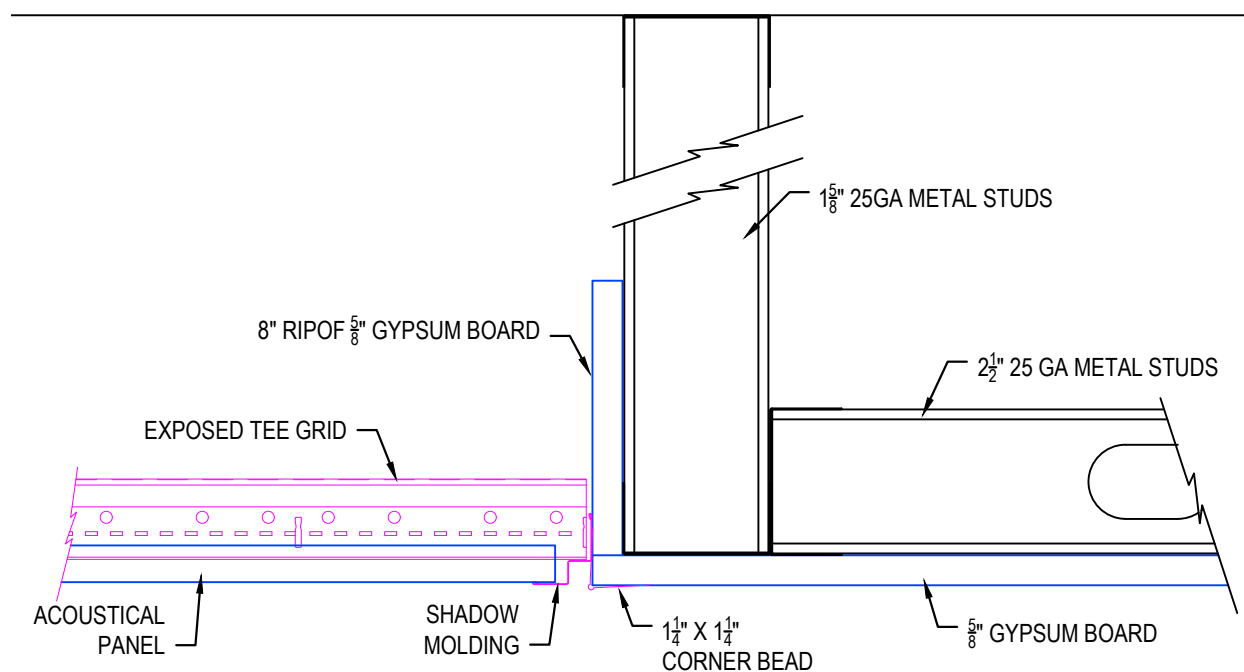

1 TRADITION FRAMING COMPARISON

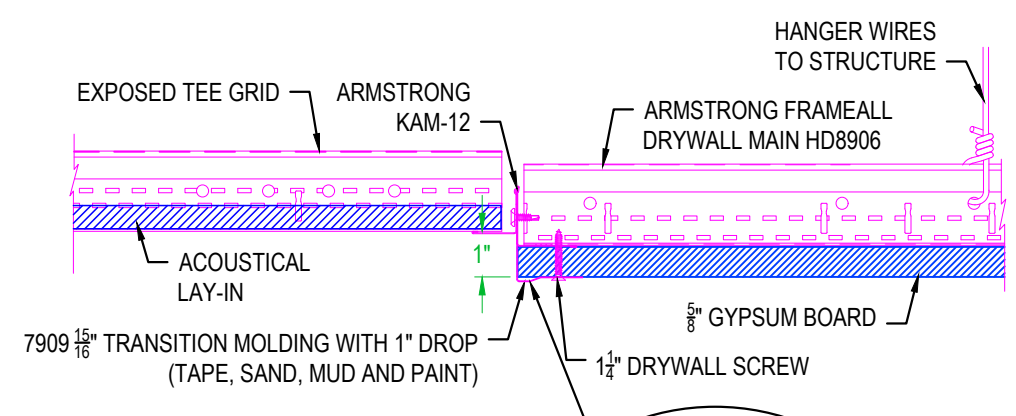

9 7909 TRANSITION MOLDING

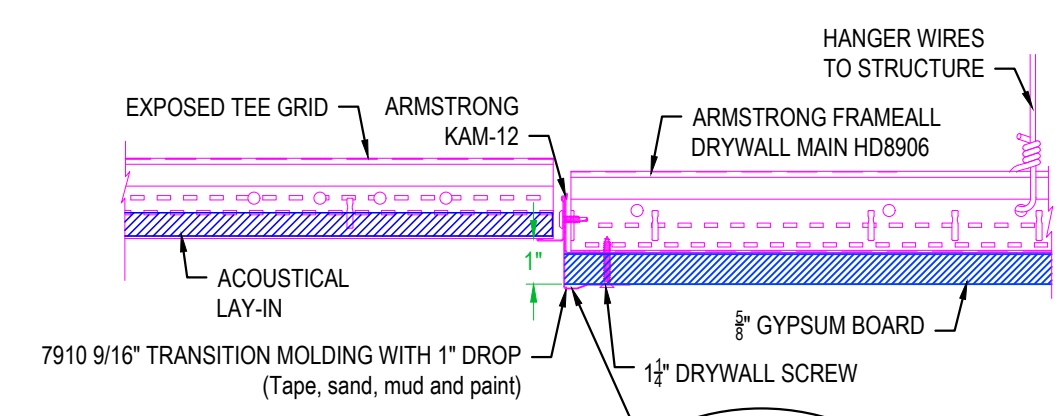
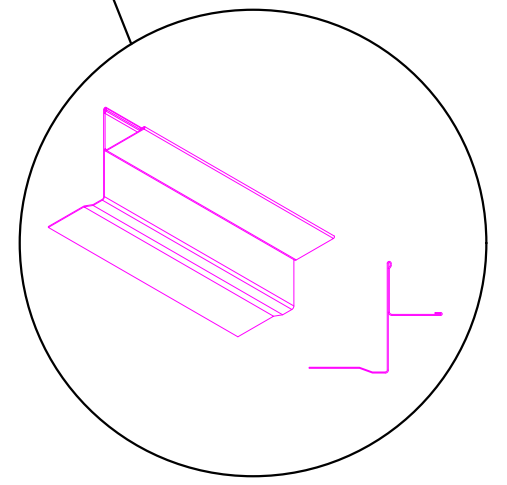

10 7910 TRANSITION MOLDING

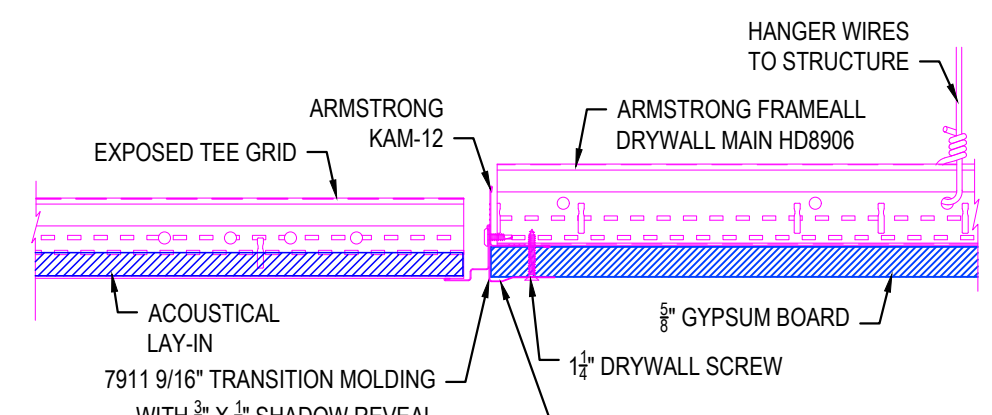
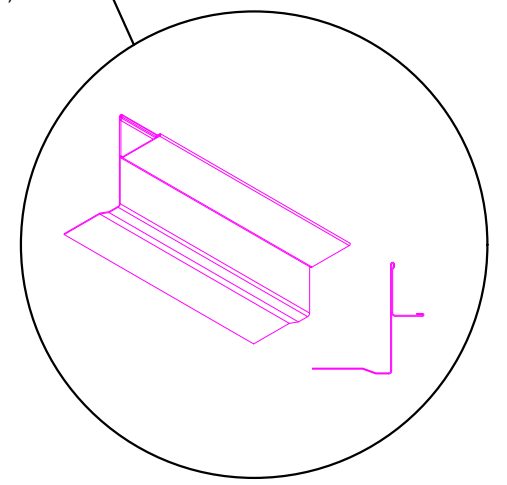

11 7911 TRANSITION MOLDING

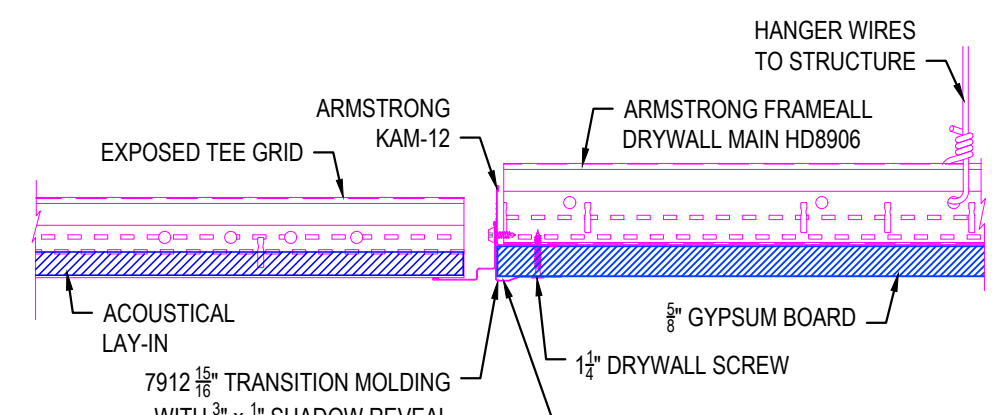
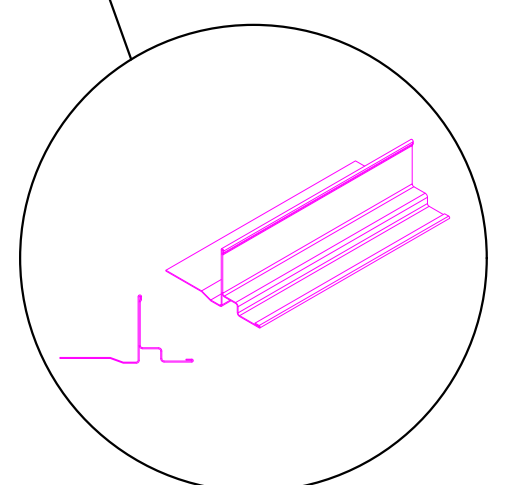

12 7912 TRANSITION MOLDING

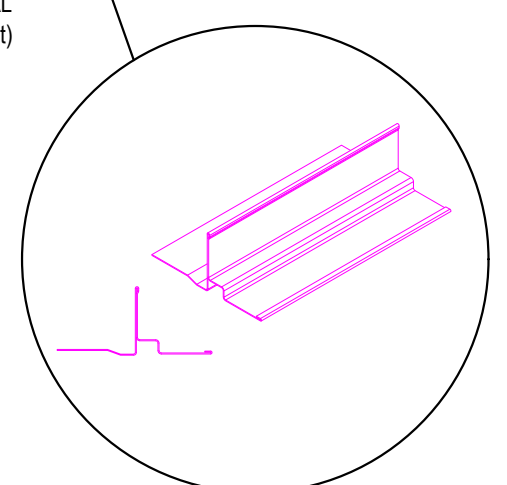

These drawings show typical conditions in which the Armstrong® product depicted is installed. They are not a substitute for an architect's or engineer's plan and do not reflect the unique requirements of local building codes, laws, statutes, ordinances, rules and regulations (Legal Requirements) that may be applicable for a particular installation.

Armstrong Ceiling Solutions does not warrant, and assumes no liability for the accuracy or completeness of the drawings for a particular installation or their fitness for a particular purpose.

The user is advised to consult with a duly licensed architect or engineer in the particular locale of the installation to assure compliance with all Legal Requirements.

Armstrong is not licensed to provide professional architecture or engineering design services.

PROJECT NAME: STEEL TRANSITION MOLDING MASTER SHEET		REV: .	DATE: .
DWG. NO. SHEET 2		SCALE: .	DESC.: .
DATE: 10/10/23	DRAWN BY: MAP	CHK BY: 3"=1'-0"	

TechLine ARMSTRONG CEILING & WALL SOLUTIONS * Lancaster, PA * Phone: 877-ARMSTRONG

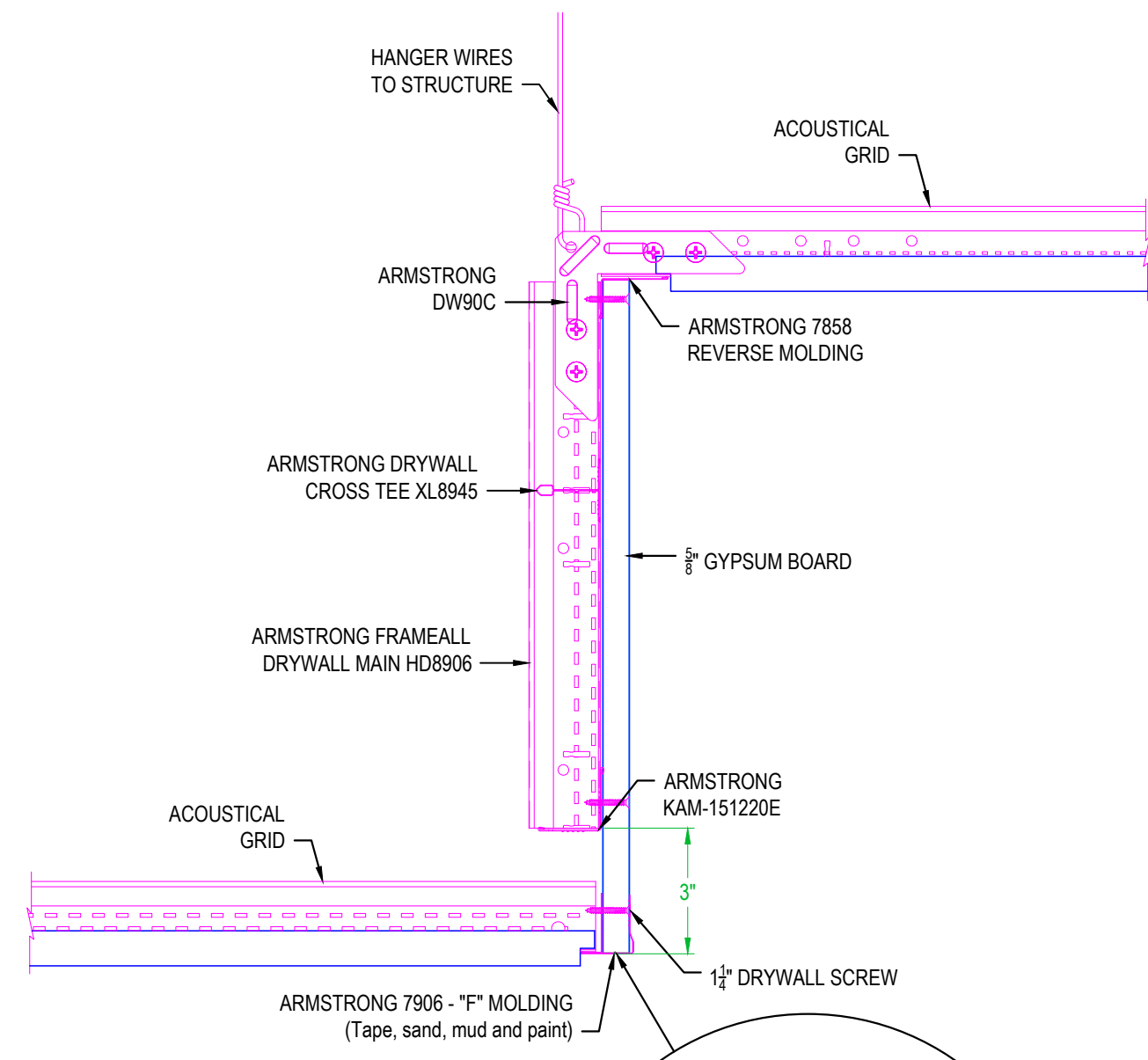

13 7906 "F" TRANSITION MOLDING

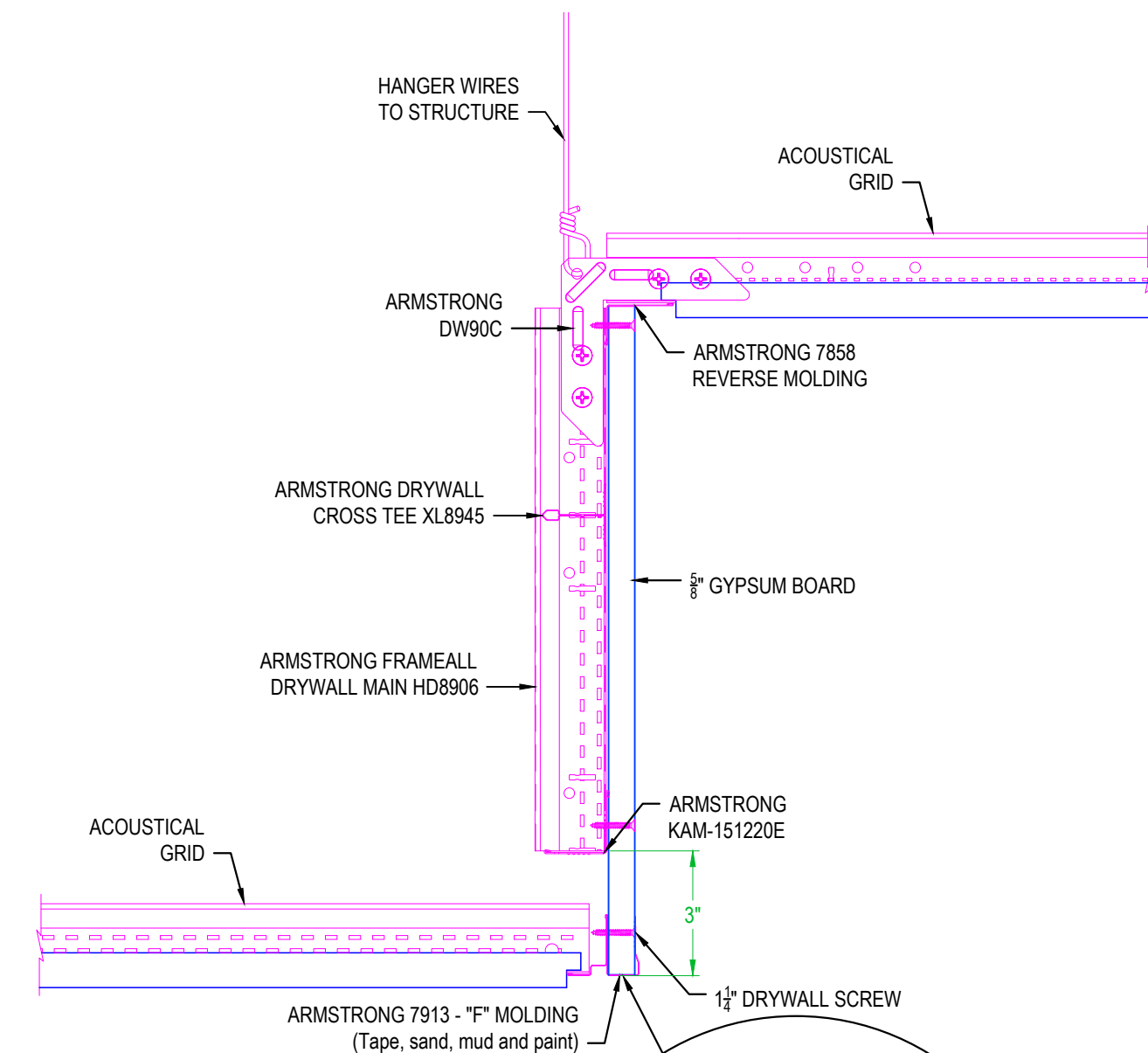
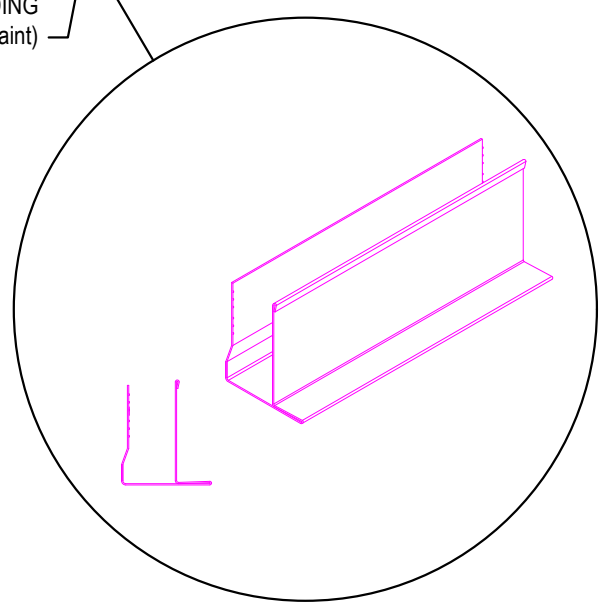

14 7913 "F" TRANSITION MOLDING

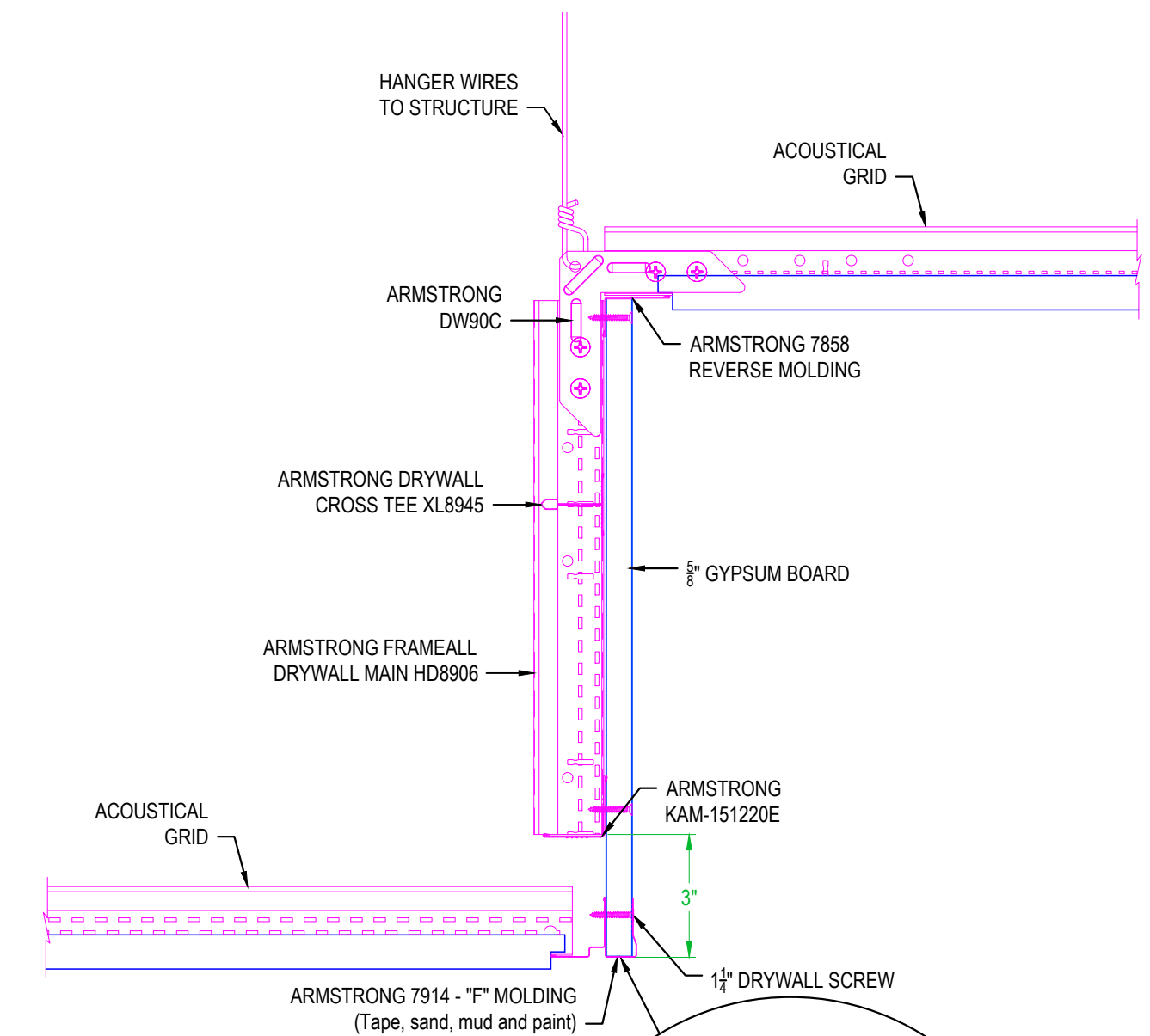
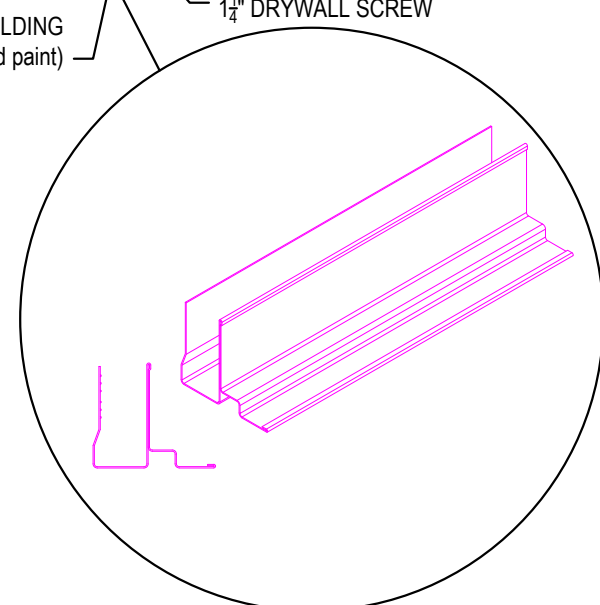

15 7914 "F" TRANSITION MOLDING

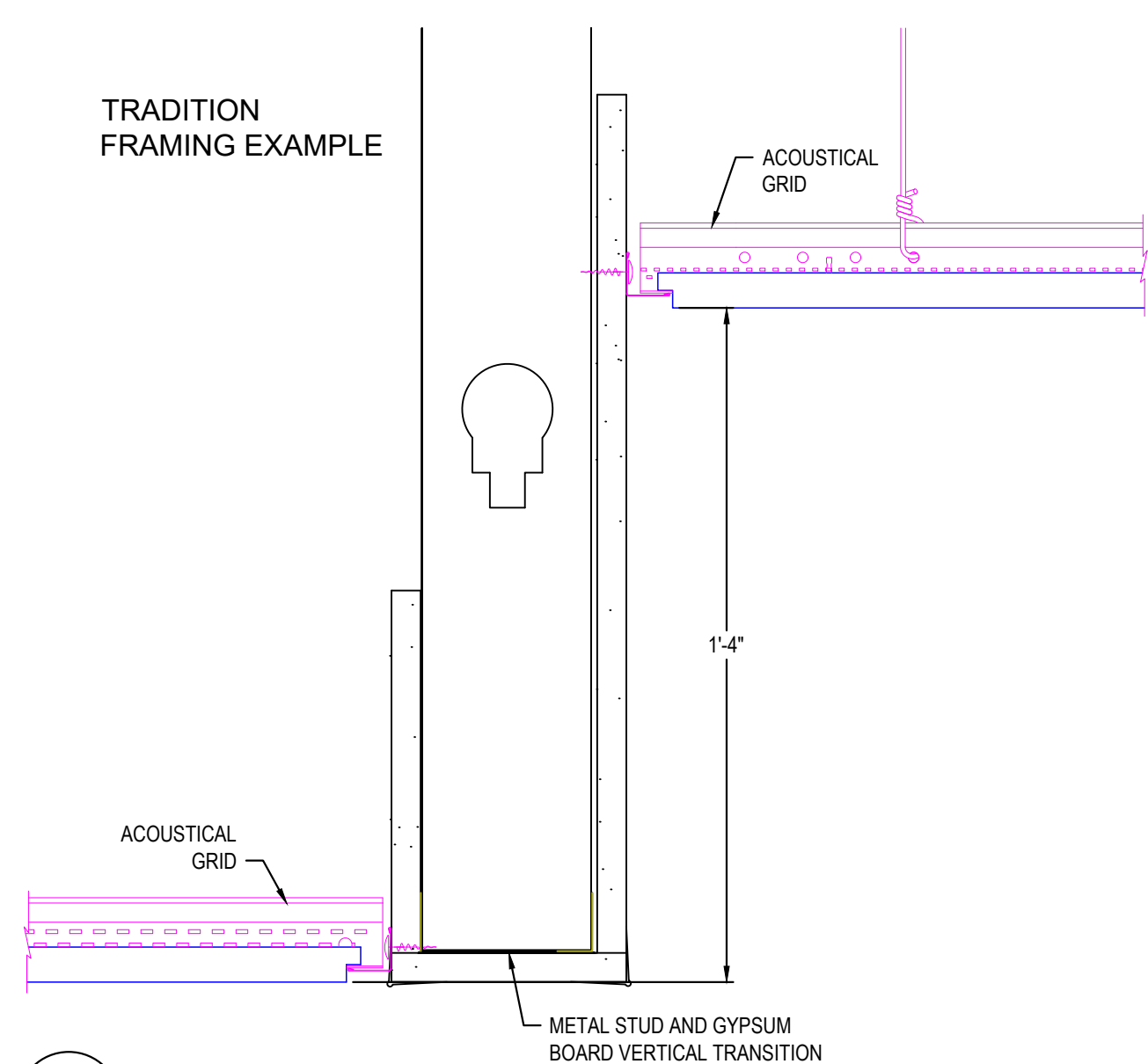
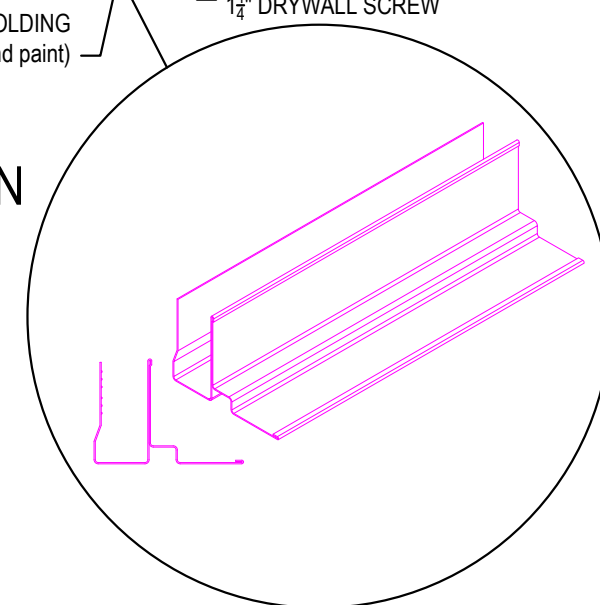

16 STUD DROP TRANSITION COMPARISON

These drawings show typical conditions in which the Armstrong® product depicted is installed. They are not a substitute for an architect's or engineer's plan and do not reflect the unique requirements of local building codes, laws, statutes, ordinances, rules and regulations (Legal Requirements) that may be applicable for a particular installation.
 Armstrong Ceiling Solutions does not warrant, and assumes no liability for the accuracy or completeness of the drawings for a particular installation or their fitness for a particular purpose.
 The user is advised to consult with a duly licensed architect or engineer in the particular locale of the installation to assure compliance with all Legal Requirements.
 Armstrong is not licensed to provide professional architecture or engineering design services.

PROJECT NAME: STEEL TRANSITION MOLDING MASTER SHEET		REV: .	DATE: .
DWG. NO. SHEET 3			
DATE: 10/10/23	SCALE: .	DESC: .	
DRAWN BY: MAP	CHK BY: 3"=1'-0"		